



Markets and Economic Requirements for Fission Batteries and Other Nuclear Systems

January 13, 2021; 10:00-1:00 Eastern

10:00: Charles Forsberg (MIT) / Andrew Foss (INL): Welcome

10:05: Youssef A. Ballout: Fission Battery Initiative

10:15: Charles Forsberg (MIT): Defining Markets, the Competition and Economic Design Constraints for Fission Batteries

10:40: Andrew Foss (INL): Market Opportunities for Fission Batteries

11:05: Eric Ingersoll (Lucid Catalyst): Nuclear hydrogen futures: The Competition

11:30: Break

11:45: Gareth Burton (American Bureau of Shipping): Fission Battery Initiative Workshop: Maritime Perspective

12:10: Bruce Dale (Michigan State University): Liquid Biofuels Energy Markets

12:35: Roundtable and Discussion

January 13, 2021

Youssef Ballout, Ph.D.

Director of the Reactor Systems Design and Analysis Division

Fission Battery Initiative

Nuclear Science and Technology

Fission Battery Initiative

Vision: Developing technologies that enable nuclear reactor systems to function as batteries.

Outcome: Deliver on research and development needed to provide technologies that achieve key fission battery attributes and expand applications of nuclear reactors systems beyond concepts that are currently under development.

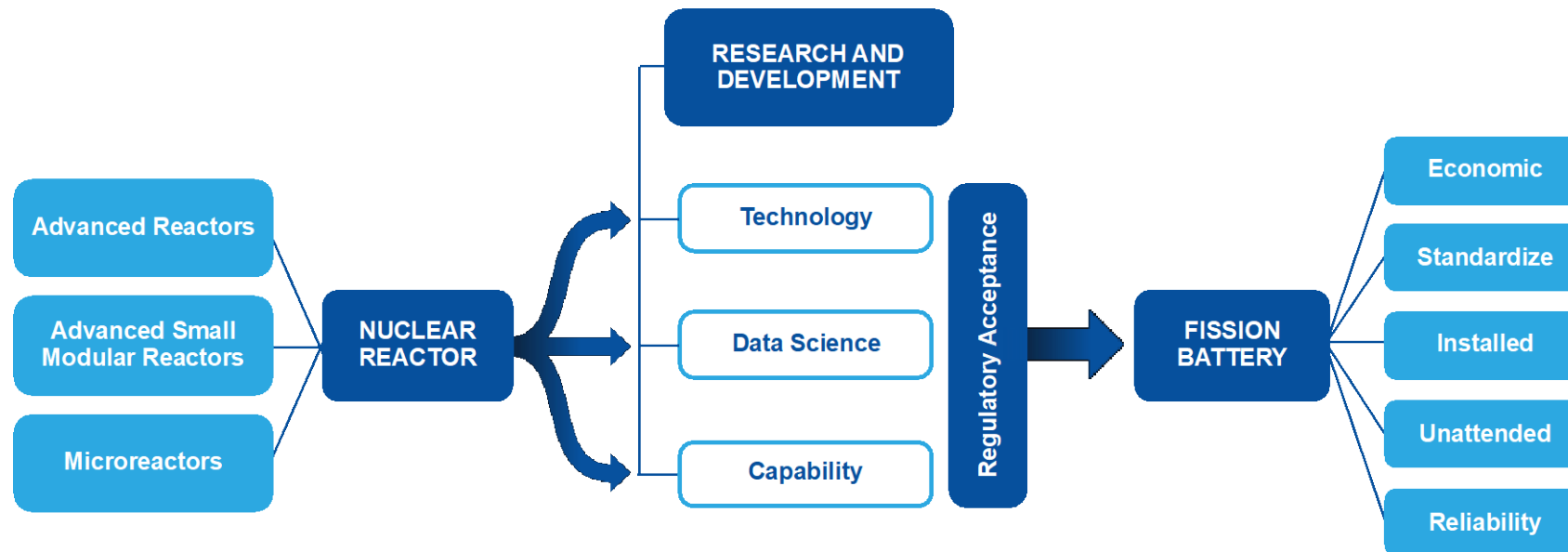

Research and development to enable nuclear reactor technologies to achieve fission battery attributes

Fission Battery Attributes

- **Economic** – Cost competitive with other distributed energy sources (electricity and heat) used for a particular application in a particular domain. This will enable flexible deployment across many applications, integration with other energy sources, and use as distributed energy resources.
- **Standardized** – Developed in standardized sizes, power outputs, and manufacturing processes that enable universal use and factory production, thereby enabling low-cost and reliable systems with faster qualification and lower uncertainty for deployment.
- **Installed** – Readily and easily installed for application-specific use and removal after use. After use, fission batteries can be recycled by recharging with fresh fuel or responsibly dispositioned.
- **Unattended** – Operated securely and safely in an unattended manner to provide demand-driven power.
- **Reliable** – Equipped with systems and technologies that have a high level of reliability to support the mission life and enable deployment for all required applications. They must be robust, resilient, fault tolerant, and durable to achieve fail-safe operation.

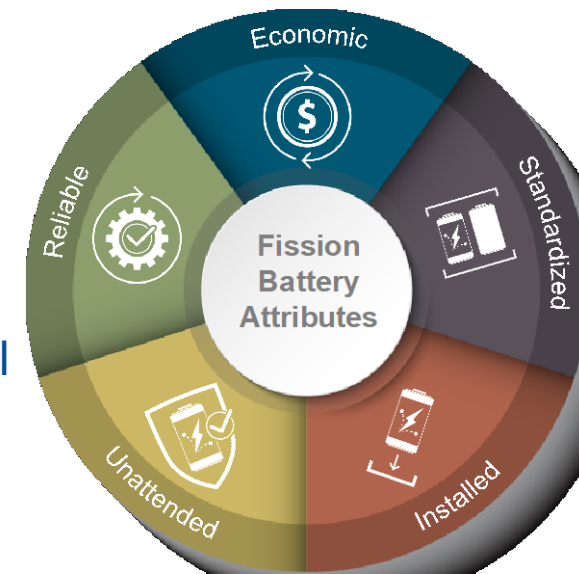

Fission Battery Workshop Series

- **Jointly INL and National University Consortium are organizing workshops across five areas:**
 - Market and Economic Requirements for Fission Batteries and Other Nuclear Systems
 - Technology Innovation for Fission Batteries
 - Transportation and Siting for Fission Batteries
 - Security Scoping for Fission Batteries
 - Safety and Licensing of Fission Batteries
- **Expected outcomes:**
 - Each workshop outcomes are expected to outline the goals of each fission battery attribute



Defining Markets, the Competition and Economic Design Constraints for Fission Batteries

Charles Forsberg

Massachusetts Institute of Technology

Email: cforsber@mit.edu

Workshop: Markets and Economic Requirements for Fission Batteries and Other Nuclear Systems

January 13 and Jan 27, 2021



Outline

- Fission Batteries: What Are They and What They Are Not
- Who Are the Potential Customers?
 - Heat Demand, Temperature Requirements, Reliability Requirements
 - How Many FBs by Category for the U.S.
- What Is the Competition?

Fission Batteries

Defined By a Set of Characteristics

Do Not Know If Can Achieve Full Set of Characteristics

Fission Battery (FB) Attributes

Small Modular Reactors and Microreactors May Have 2 or 3 Attributes

- *Economic*: Cost competitive with other distributed energy sources (electricity and heat) used for a particular application in a particular location.
- *Standardized*: Developed in standardized sizes and power outputs with manufacturing processes that enable universal use and factory production to lower costs and more reliable systems (Manufacturing scale similar to jet engines and aircraft).
- *Installed*: readily and easily installed for use and removed after use. Creates a competitive energy market where user is not an economic hostage to the supplier.
- *Unattended*: Operate securely and safely while unattended to provide demand-driven power
- *Reliable*: Systems and technologies must have a high level of reliability to provide a long life and enable wide-scale deployment for applications.

Fission-Battery Customer Interface

- Drop-in reactor with minimum site infrastructure; may replace reactor rather than refuel reactor (Battery model)
- Most customers are not in the energy or power business—they do not sell heat or electricity as a business
- Customers need energy to heat buildings, produce products and other purposes
- Customer may own or lease fission batteries

The Fission Battery (FB) Is Not Defined By Power Output

- Different viewpoints on FB size
 - Proposals from <1 to 100 MWt
 - Technical challenges with larger power output
 - Example: Assured decay heat removal if no local security to assure decay heat rejection to atmosphere
- **Economic questions (Speaker: Andrew Foss)**
 - **What is the market size (number of units) for different power levels? May deploy multiple FBs per customer**
 - **Is market sufficiently large to support factory production?**

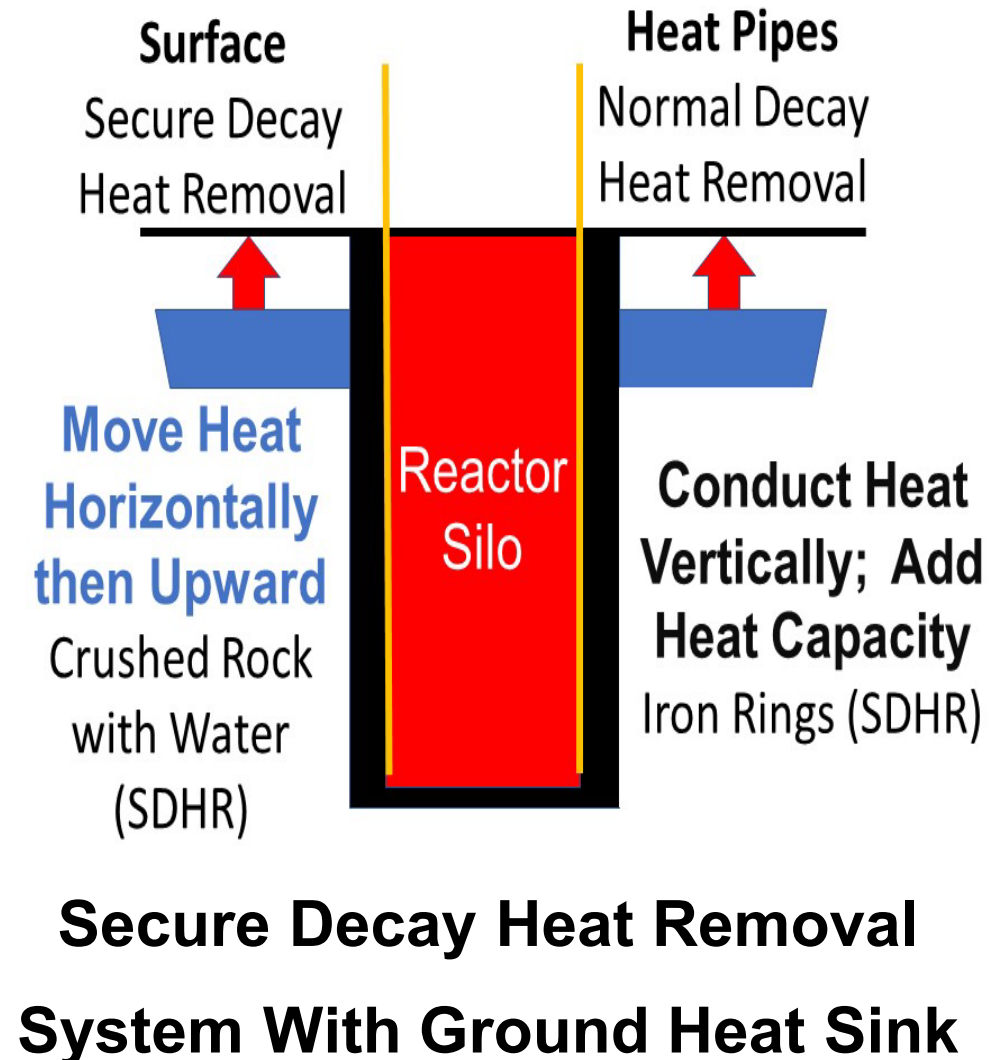

Who Are the Potential Customers?

Two Primary Energy Production Systems: Electricity and Heat

Produce Electricity

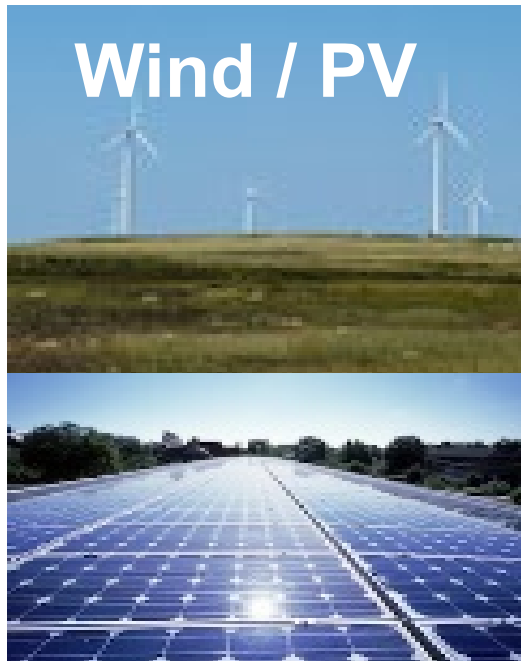

Produce Heat



Nuclear Reactors Produce Heat

Most Energy Is Consumed As Heat

Industrial Heat Demand Twice Total Electricity Production

Estimated U.S. Energy Consumption in 2019: 100.2 Quads

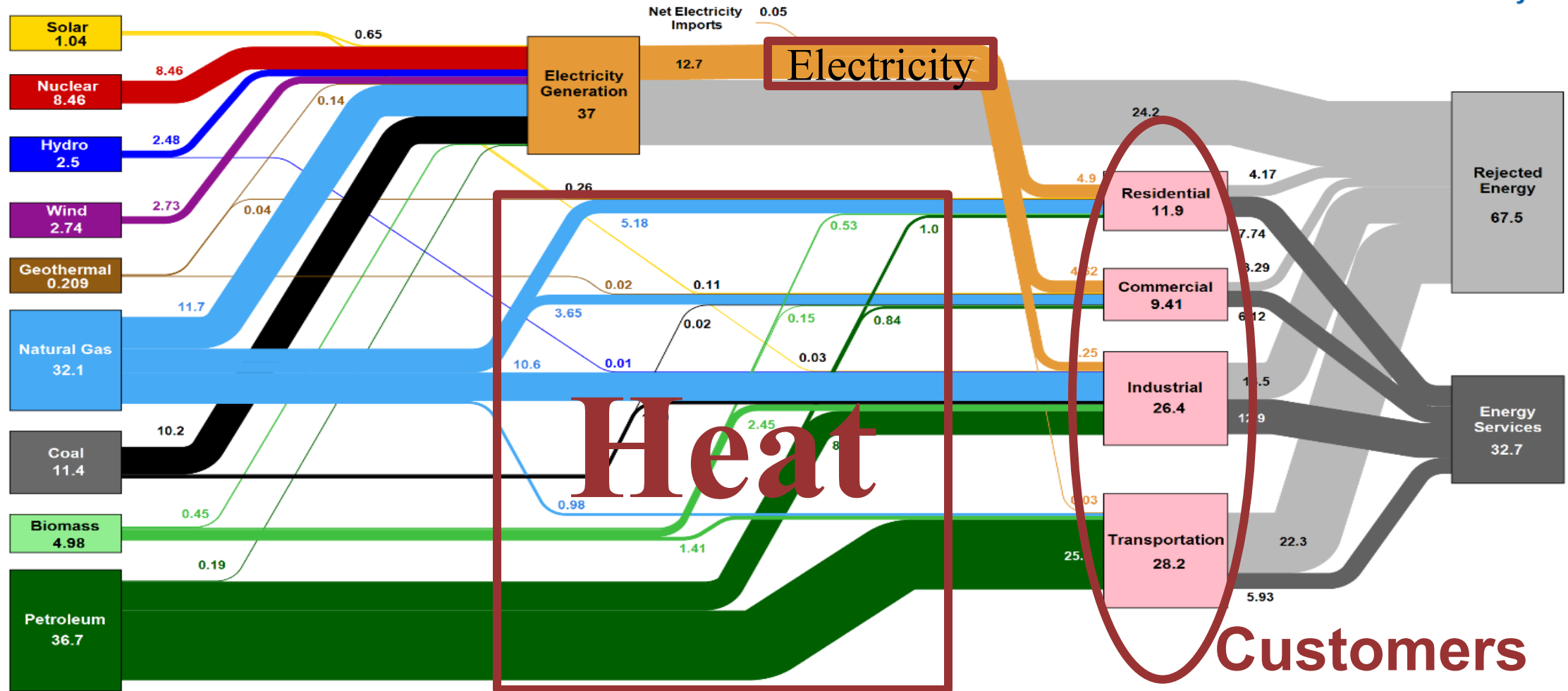

Making Electricity from Heat is Expensive: Thermodynamics of Power Cycles

Multiple Units of Heat → One Unit Electricity



1 Unit of Electricity → One Unit of Heat



Heat Generating Technologies Tend to Produce Low-Cost Heat;
Electric Generating Technologies Tend to Produce Low-Cost Electricity

Expected Fission Battery Markets

- *Heat*: Competitive advantage
- *Work (Electricity)*: Non-utility markets with special requirements
 - Ships
 - Ultra-high reliability or quality (Data centers, etc.)
 - Off-grid locations
- **May sell excess energy to grid (cogeneration) but not likely to be economic basis to buy or lease fission battery**

There Are Many Markets and a Large Numbers of Potential Customers

- Existing U.S. heat users (Speaker: Andrew Foss)
 - Industry, schools, agriculture, etc.
 - Over 6000 users with heat demand greater than 1 MWt
- Biofuels (Speaker: Bruce Dale)
- Chemicals
- Ships and other maritime applications (Speaker: Gareth Burton)
- Special electricity markets (data centers, others)

Fission Battery Has a Different Ownership Model

- **Most fission battery customers are not in the energy business** —just need heat and/or electricity for their business (Speaker: J. Parsons)
- May own or lease fission battery—like leasing trucks or other equipment (Speaker: Elina Teplinsky)
- If a problem, call the vendor to fix

What Is the Competition?

Defines Fission Battery Economic Goals

There are Multiple Potential Competitors

Hypothetical Cost of Heat Vs Customer Energy Demand

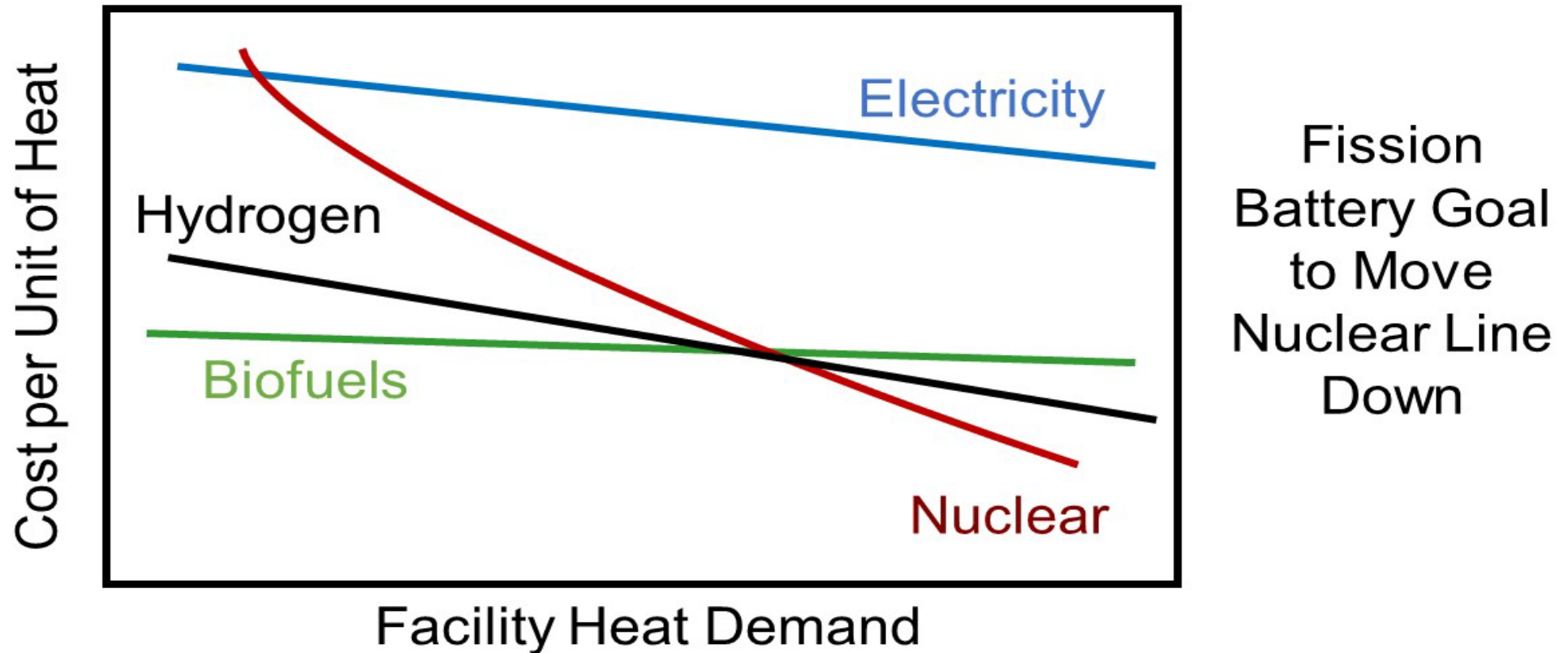

Workshop To Begin to Define Real-World Numbers

The Competition: Grid Electricity

Expensive Energy Source
Really Expensive Heat Source

Electricity Six Times More Expensive than Heat

- Electricity is great except:
 - Expensive to produce
 - Expensive to ship
 - Expensive to store
- We use heat because it is cheap to produce and store

Selected U.S. average energy prices (1970-2016)
dollars per million British thermal units (real \$2016)

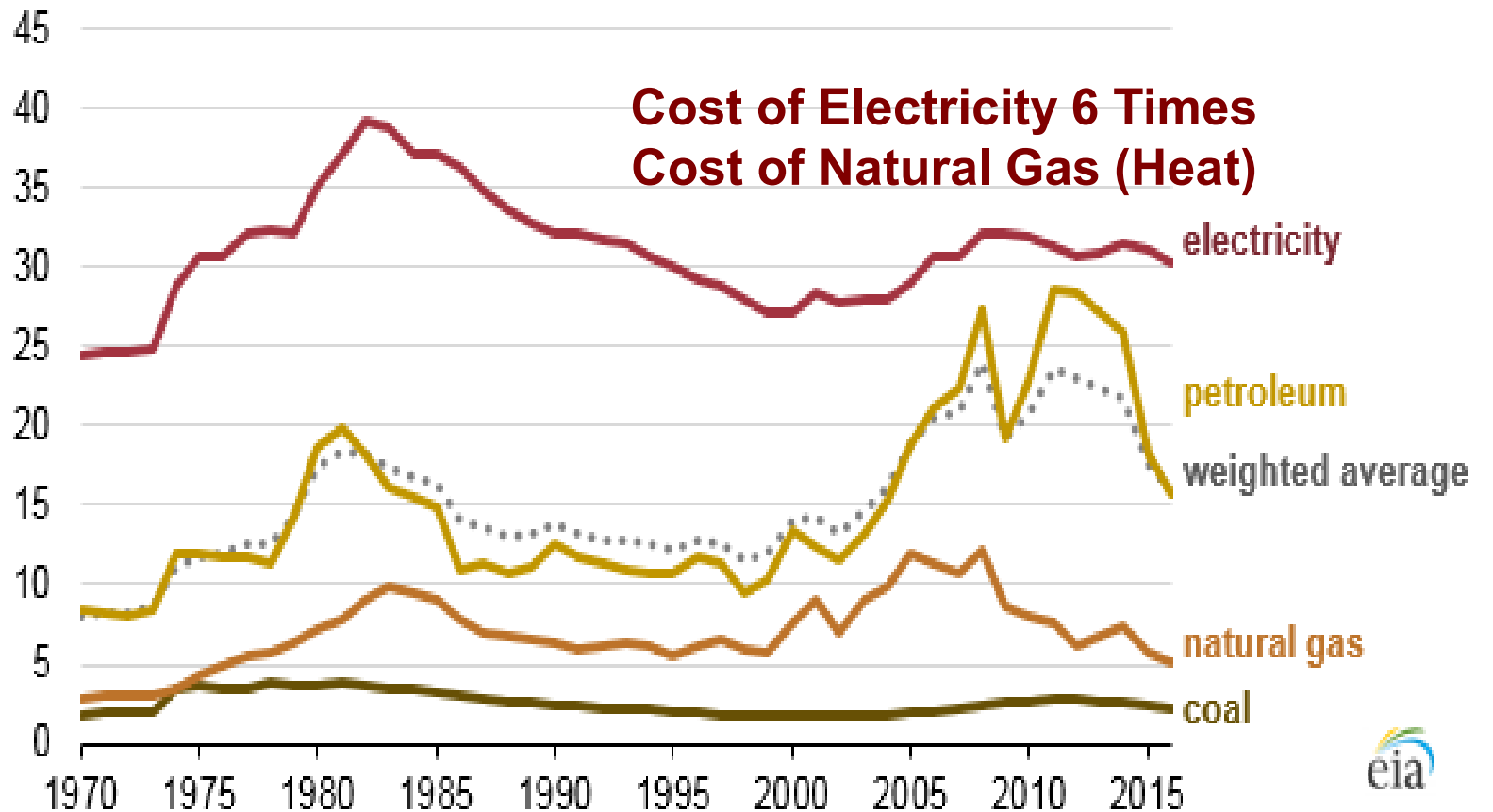

Delivered Electricity Price (2019) Has Three Components

- Components
 - Generation (blue)
 - Transmission (brown)
 - Distribution (green)
- Transmission and Distribution Costs increase with Wind & Solar
- **Electricity is more expensive than heat even if the cost to produce electricity was zero**

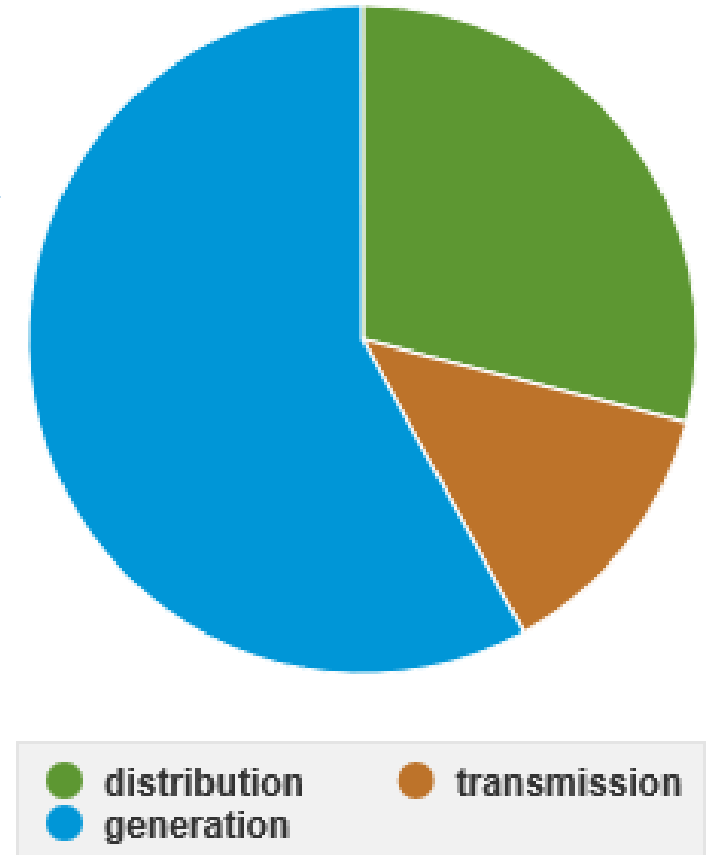

The Competition: Co-Generation Using Large Nuclear Reactors or Fossil Fuels with Carbon Capture and Sequestration

Co-Generation With Large Central Heat-Generating Technology and Distributed Heat to Customers

- Co-generation enables large-scale energy sources to provide heat and electricity to multiple customers
- Two options
 - Large nuclear plants (Any location)
 - Fossil fuels with carbon capture and sequestration (Locations with sequestration sites)
- **Economic heat but implies rebuilding much of U.S. industry to collocate with heat sources**
- Business challenge of how to organize such systems creates incentives for fission batteries (Speaker: J. Parsons)

The Competition

Hydrogen (Speaker: Eric Ingersoll)

Hydrogen Can Replace Natural Gas But at What Price?

- Production options
 - Steam methane reforming with CCS
 - Low or high-temperature electrolysis
- Can be cheaply stored like natural gas in underground facilities
- Premium energy source like electricity but two important differences
 - Cheap storage
 - Transport via pipeline



**Chevron-Phillips Clemens Terminal
(160' X 1,000' Cylinder Salt Cavern)**

What Are The Constraints?

Multiple Constraints for Fission Batteries

- Small output places major economic constraints on operations
 - Must minimize manpower and allowable fuel costs to be economically competitive (Speaker: Jacopo. Buongiorno)
 - Rethink manpower-intensive security (Speaker: Paul Roege)
- Major business questions
 - Leasing and Liability (Speaker: Elina Teplinsky)
 - Licensing (Separate Workshop in this series)
- Technical challenges (Separate Workshops in this series)

Conclusions

- Low-carbon world implies radical changes in energy systems
- Fission batteries are one solution
 - Defined by attributes, not technology
 - We do not know the maximum output of a fission battery
- Economics workshop goals (Two webinars)
 - Define the market—number of customers for different heat demands at different temperatures
 - Understand the competition
 - Understand the constraints
 - Business and legal (Leasing, licensing and liability)
 - Economic constraints on technical choices

Backup / Other Information

Biography: Charles Forsberg

Dr. Charles Forsberg is a principal research scientist at MIT. His research areas include Fluoride-salt-cooled High-Temperature Reactors (FHRs) and utility-scale heat storage including Firebrick Resistance-Heated Energy Storage (FIRES). He teaches the fuel cycle and nuclear chemical engineering classes. Before joining MIT, he was a Corporate Fellow at Oak Ridge National Laboratory.

He is a Fellow of the American Nuclear Society, a Fellow of the American Association for the Advancement of Science, and recipient of the 2005 Robert E. Wilson Award from the American Institute of Chemical Engineers for outstanding chemical engineering contributions to nuclear energy, including his work in waste management, hydrogen production and nuclear-renewable energy futures. He received the American Nuclear Society special award for innovative nuclear reactor design and is a Director of the ANS. Dr. Forsberg earned his bachelor's degree in chemical engineering from the University of Minnesota and his doctorate in Nuclear Engineering from MIT. He has been awarded 12 patents and published over 300 papers.



Fission Battery (FB) Attributes

- *Economic*: Cost competitive with other distributed energy sources (electricity and heat) used for a particular application in a particular domain. This will enable distributed energy resources through flexible deployment across many applications and integration with other energy sources.
- *Standardized*: Developed in standardized sizes and power outputs with manufacturing process that enables universal use and factory production. This will lower costs and produce more reliable systems that achieve faster qualification
- *Installed*: readily and easily installed for use and removed after use. After use they can be recycled by recharging with fresh fuel or responsibly dispositioned
- *Unattended*: Operate securely and safely while unattended to provide demand-driven power
- *Reliable*: Systems and technologies must have a high level of reliability to provide a long life and enable wide-scale deployment for applications. To support the concept of remote monitoring, they must be robust, resilient, fault tolerant and durable, and provide advance notification when replacement is needed

Thermodynamics Defines Two Types of Energy

- Heat is produced by
 - Burning fossil fuels
 - Nuclear power plants
 - Concentrated solar power (CSP) plants
- Work (electricity, mechanical movement, etc.) produced by
 - Hydroelectric plants
 - Solar Photovoltaic
 - Wind

Nuclear and Fossil with Carbon Capture and Sequestration Co-generation Have Many Similarities

- Safety case is important
 - Nuclear: radioactive source term
 - Fossil fuels: carbon dioxide heavy gas that can asphyxiated people
- Two options
 - Large nuclear plants (Any location)
 - Fossil fuels with carbon capture and sequestration (Locations with sequestration sites)
- Likely the primary competition in a zero-carbon world but implies rebuilding most U.S. industry to collocate with heat source

A Low-Carbon World Changes Energy Markets

- Major heat users—future directions
 - Paper, pulp and forestry
 - Chemicals
- Liquid Biofuels May Replace Liquid Fossil Fuels (Bruce Dale Talk)
 - Zero-carbon liquid hydrocarbon fuels, carbon from air via plants
 - **Liquid fuels yield per ton of biomass doubled with external heat and hydrogen input—10 to 20% total U.S. energy consumption and major nuclear energy market**
 - **Nuclear Biofuels Workshop (Forsberg / Dale contact)**

January 13, 2021

Andrew Foss

INL Technical Program Lead –
Nuclear Energy Markets, Economics, and Systems Analyses

Market Opportunities for Fission Batteries

Fission Battery Economics Workshop

Key Questions for Fission Battery Development

- 1. What are the markets and customers?**
 - Meeting societal needs for more clean energy
- 2. What is the optimal unit size?**
 - Alignment with customer needs
- 3. What is the total market opportunity?**
 - Unit size (and revenue) per customer x number of customers
- 4. What is the optimal outlet temperature?**
 - Alignment with customer needs

US Electricity and Heat Consumption

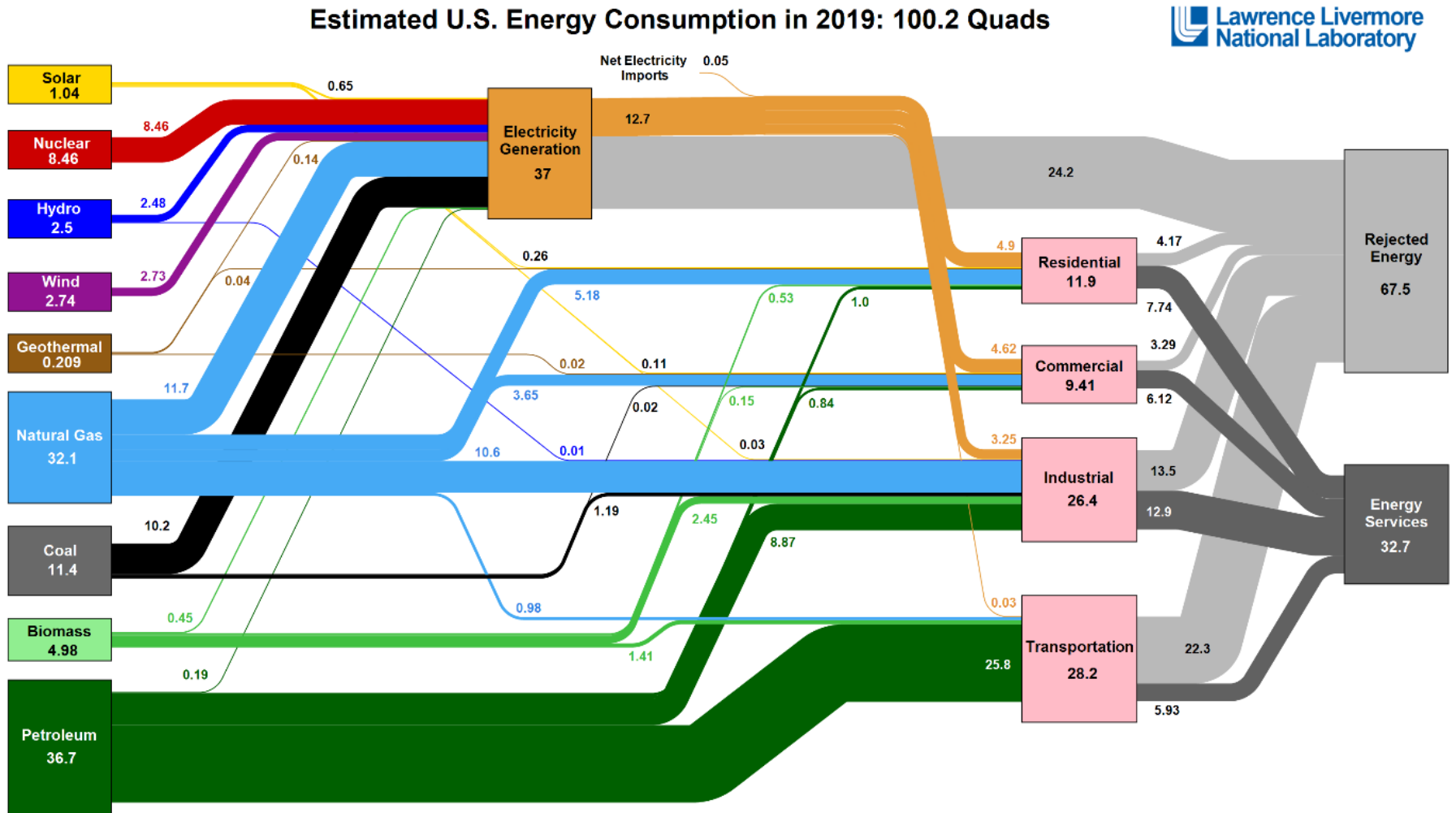

Source: Lawrence Livermore National Laboratory
https://flowcharts.llnl.gov/content/assets/docs/2019_United-States_Energy.pdf

What Roles for Nuclear in Deep Decarbonization?

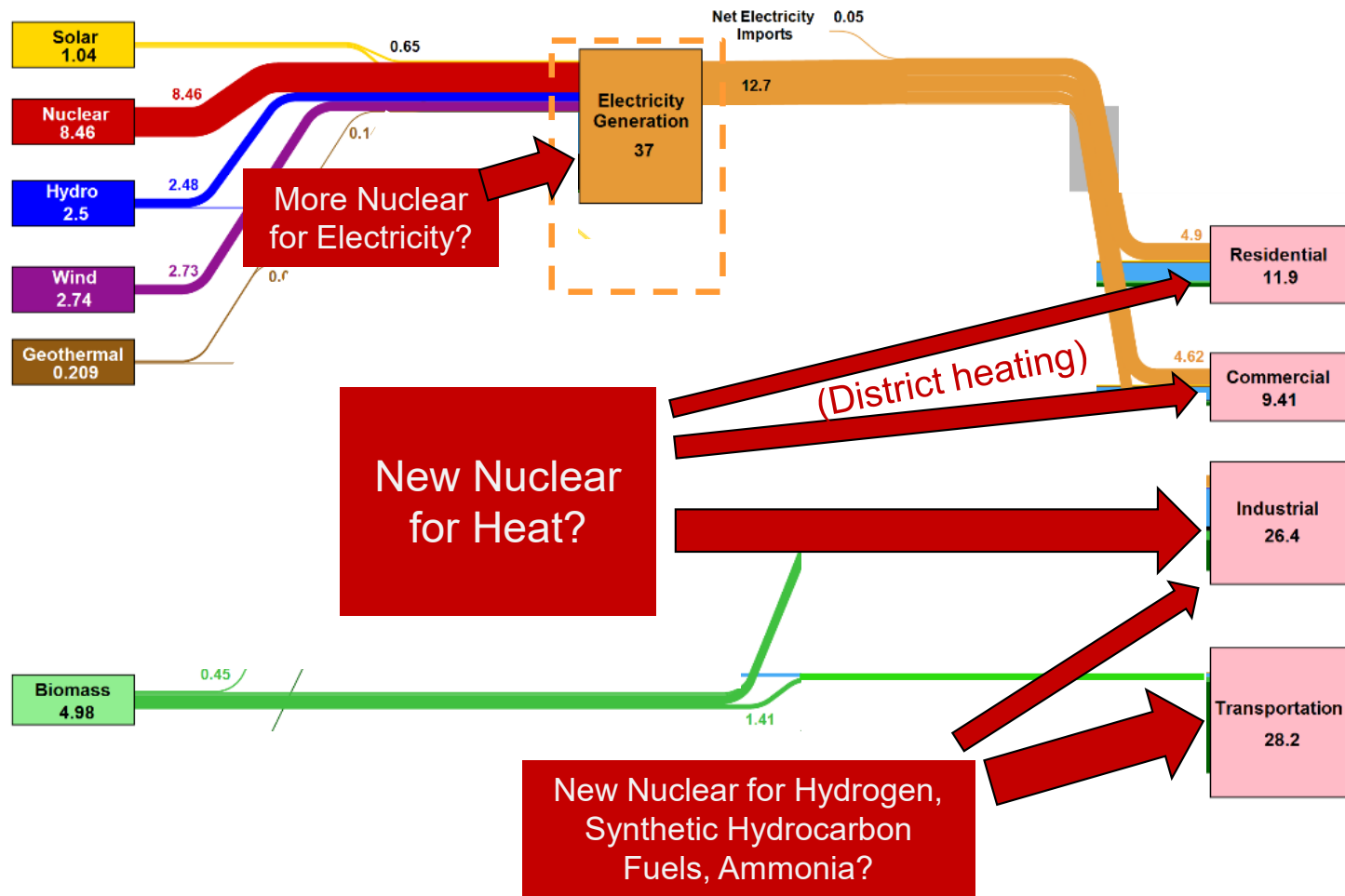

(Removal of fossil energy is only for illustrative purposes, not a prediction – and CCS is also a decarbonization option)

Electricity Markets for Fission Batteries

- Regional grid
- Microgrids
- Remote communities
- Military bases
- Mines



Sources: New Atlas, Sandia National Lab, Alaska Dispatch News, ABC News, Teck Resources

Analysis of Industrial Heat Demand

What is the typical thermal load at facilities within each industrial sector, and what is the spread? -> **Histograms**

1. EPA FLIGHT database of CO₂ emissions from ~6,000 large facilities
 - Companies, addresses, industry codes (NAICS)
 - Emissions linked to coal, natural gas, and oil consumption
2. CO₂ emission factors (lbs per MMBtu) for coal, natural gas, and oil
3. Combine 1 and 2 -> Annual energy consumption at large facilities
4. Annual facility utilization assumption (90%)
5. Combine 3 and 4 -> Average thermal power load at large facilities

Similar previous analyses (for industrial sectors in aggregate rather than histograms of facility loads): INL and NREL, *Generation and Use of Thermal Energy in the U.S. Industrial Sector and Opportunities to Reduce its Carbon Emissions*, 2016; MIT, *The Future of Nuclear Energy in a Carbon-Constrained World*, 2018 (Appendix F)

Largest Industrial Sectors for Heat Demand

	Industry	Facility Count	Total CO ₂ (million metric t)	Total Energy (trillion Btu)	Total Thermal Load (MWt)
#1	Electric utilities	1,394	1,795	23,809	885,741
#2 *	Chemical manufacturing	650	176	2,487	92,536
#3	Pipeline transportation	630	29	388	14,452
#4	Oil and gas extraction	588	62	833	30,993
#5	Waste management	571	11	142	5,292
#6	Cement, glass, mineral mfg.	350	106	1,407	52,347
#7 *	Food manufacturing	327	33	474	17,649
#8	Primary metal manufacturing	275	87	1,155	42,967
#9 *	Paper manufacturing	216	35	516	19,203
#10 *	Petroleum manufacturing	171	209	2,797	104,067
	Other	641	45	673	25,049
	Total	5,813	2,587	34,684	1,290,295

Data for 2018 ranked by facility count
 Asterisk denotes sectors with histograms on next slides

Heat Demand for Petroleum Manufacturing

	Industry	Facility Count	Total CO ₂ (million metric t)	Total Energy (trillion Btu)	Total Thermal Load (MWt)
#10	Petroleum manufacturing	171	209 (avg 1.2 per facility)	2,797 (avg 16 per facility)	104,067 (avg 609 per facility)

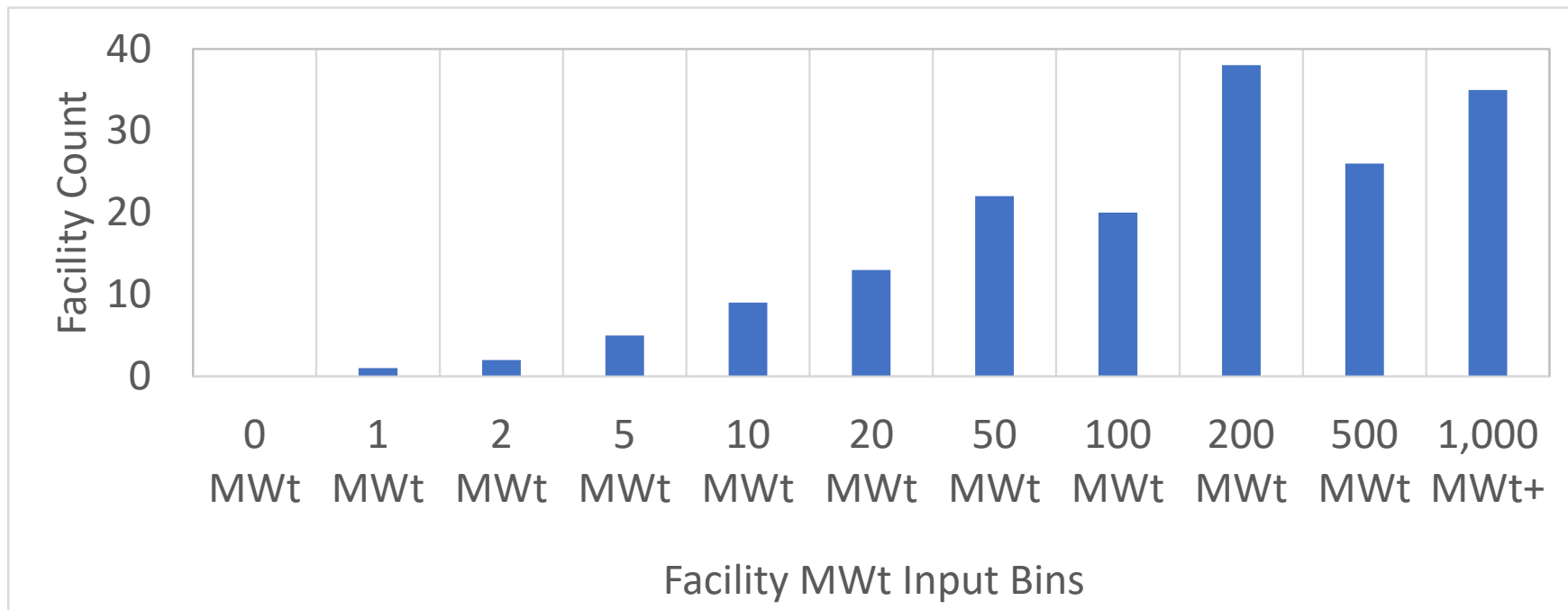

Temperature needs: Up to 750 C (fluid catalytic cracker)

Heat Demand for Chemical Manufacturing

	Industry	Facility Count	Total CO ₂ (million metric t)	Total Energy (trillion Btu)	Total Thermal Load (MWt)
#2	Chemical manufacturing	650	176 (avg 0.3 per facility)	2,487 (avg 3.8 per facility)	92,536 (avg 142 per facility)

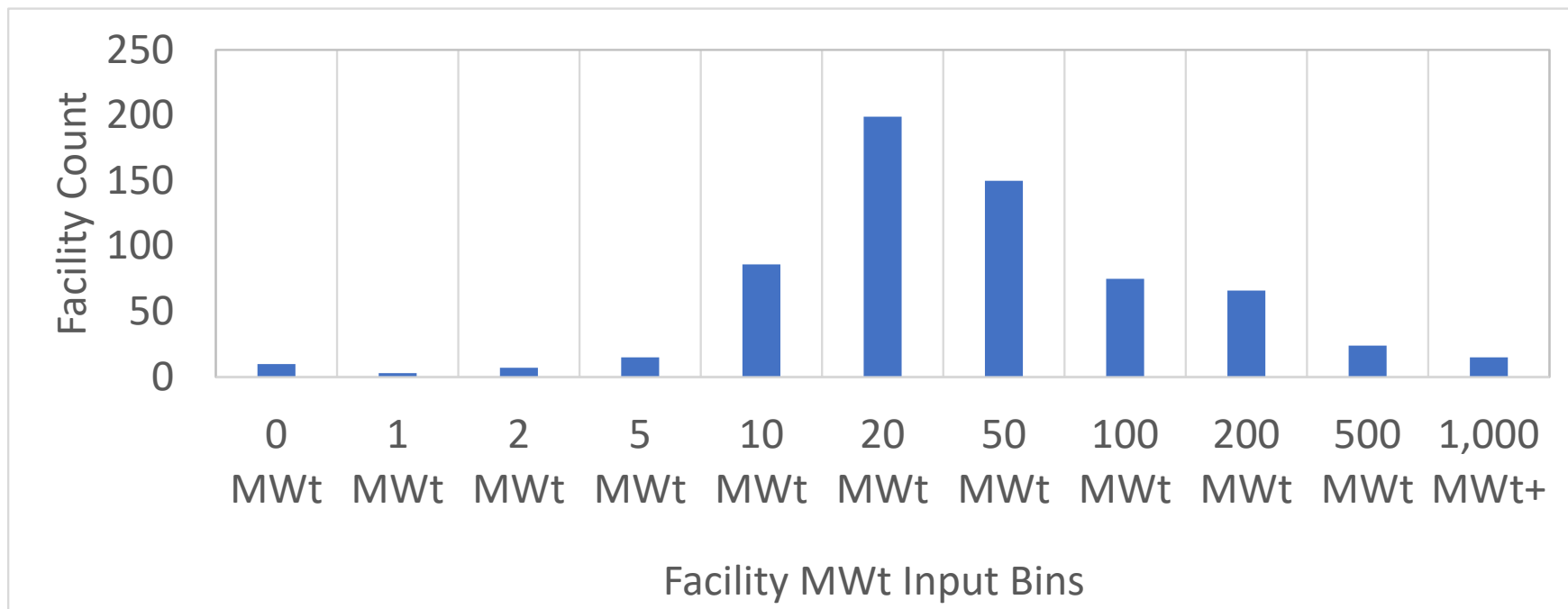

Several processes around 500 C

We have invited chemical industry representatives for the second session (Jan 27)

Heat Demand for Paper Manufacturing

	Industry	Facility Count	Total CO ₂ (million metric t)	Total Energy (trillion Btu)	Total Thermal Load (MWt)
#9	Paper manufacturing	216	35 (avg 0.2 per facility)	516 (avg 2.4 per facility)	19,203 (avg 89 per facility)

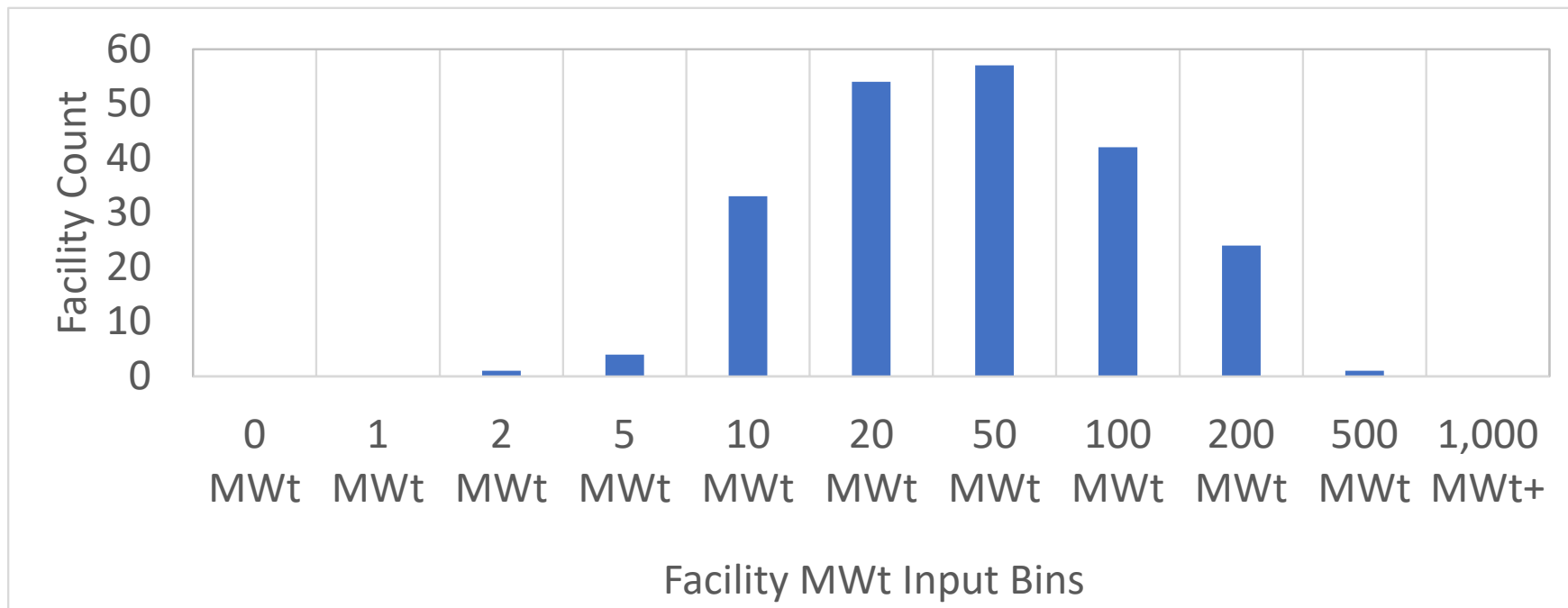

Most processes 200 - 300 C

We have invited a paper industry representative for the second session (Jan 27)

Heat Demand for Food Manufacturing

	Industry	Facility Count	Total CO ₂ (million metric t)	Total Energy (trillion Btu)	Total Thermal Load (MWt)
#7	Food manufacturing	327	33 (avg 0.1 per facility)	474 (avg 1.5 per facility)	17,649 (avg 54 per facility)

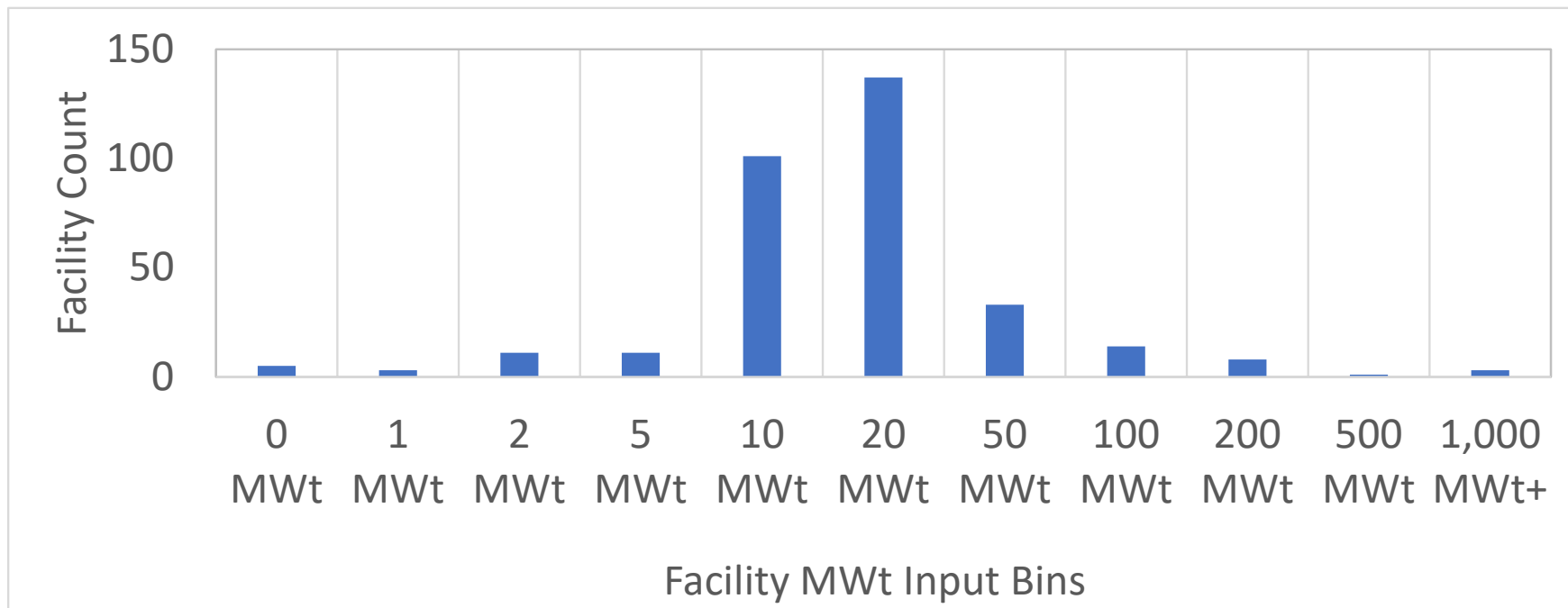

Most processes around 200 - 300 C

Nuclear Reactor Temperatures

Light-water reactors	300 C
Sodium fast reactors	500 C
Supercritical-water-cooled reactors	500 - 550 C
Lead-cooled fast reactors	500 - 800 C
Molten salt reactors	600 - 700 C
Fluoride-salt-cooled high-temperature reactors	600 - 700 C
High-temperature gas-cooled reactors	700 - 850 C
Very high-temperature reactors	900 - 1000 C

If temperature is too high for customer needs, just pass fluid through turbines to cool it

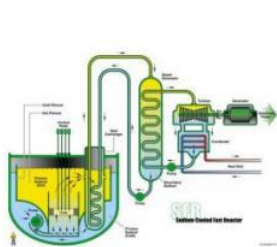

Sodium Fast Reactor

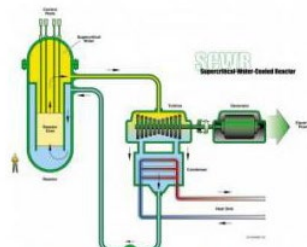

Supercritical Water Cooled Reactor

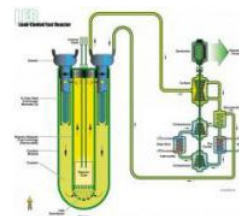

Lead Fast Reactor

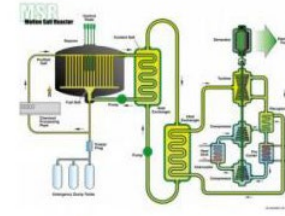

Molten Salt Cooled Reactor

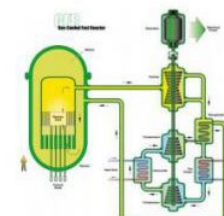

Gas Cooled Fast Reactor

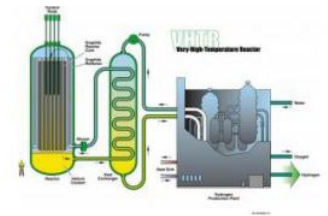

Very High Temperature Reactor

Sources: MIT, *The Future of Nuclear Energy in a Carbon-Constrained World*, 2018
Generation IV International Forum

Aligning FB Temps and Sizes with Sector Needs

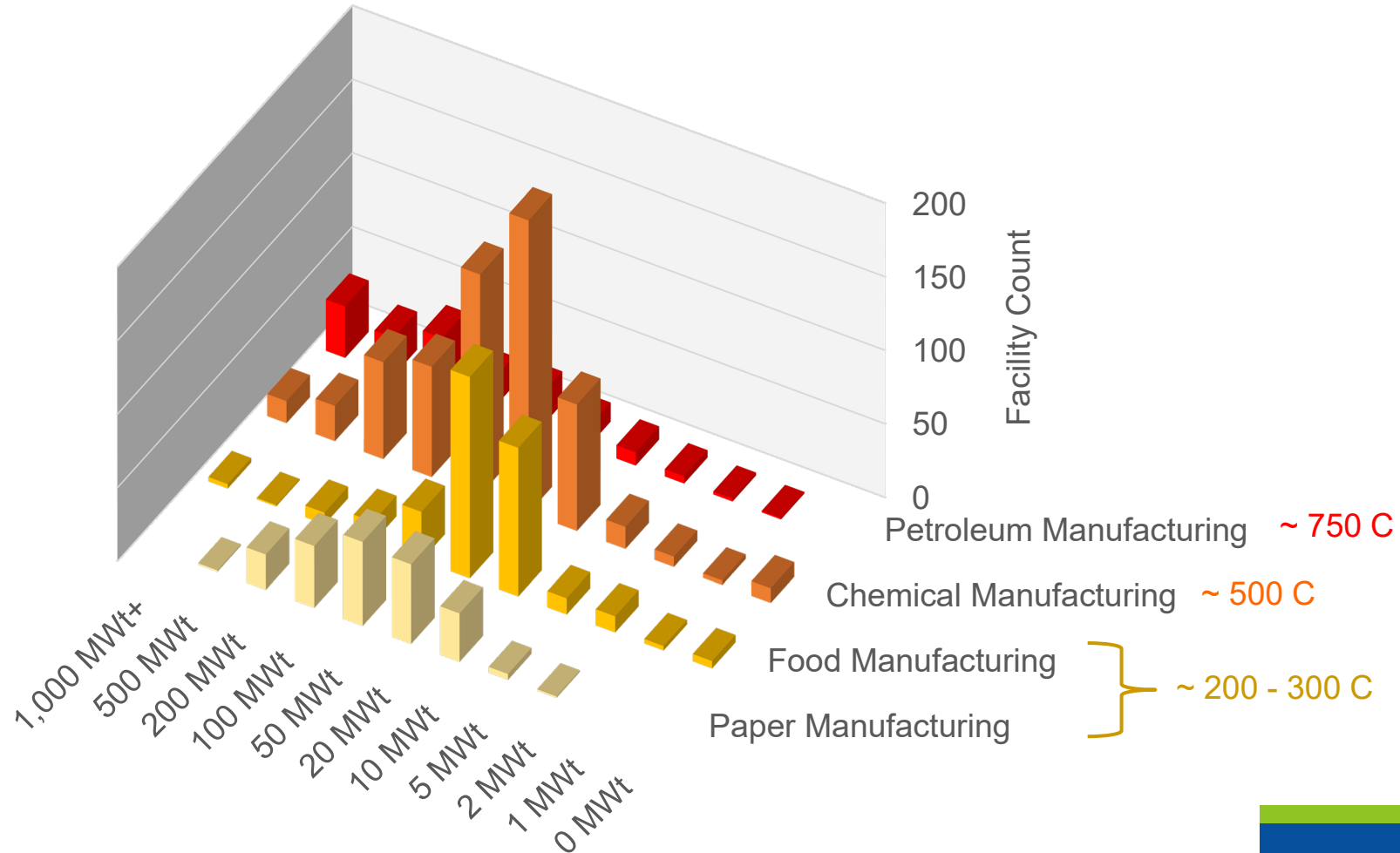

Cost Competitiveness of Fission Batteries

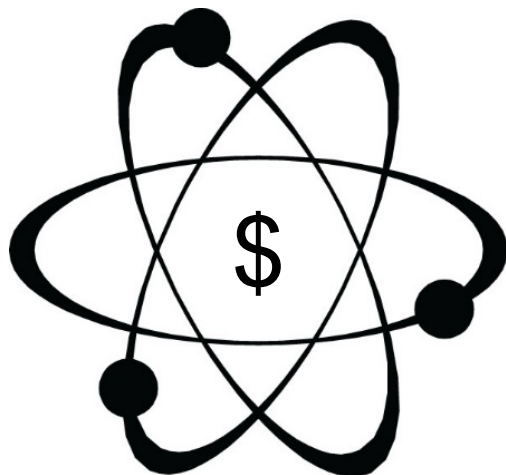
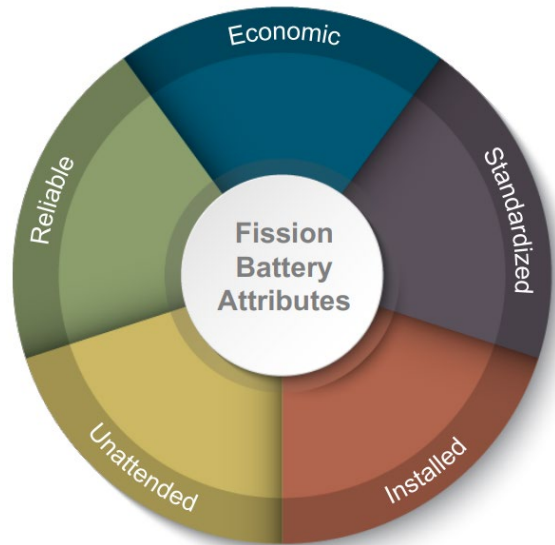

- **Standardization**
 - Avoid customization engineering
 - Streamline site-specific review and permitting
- **Factory manufacturing**
 - Modular components or entire units
 - Efficient inspection in factory
- **Economies of multiples**
 - Fast first-to-Nth reductions if many units
 - Multiple units per site? Multiple customers?
- **Quick and easy installation**
 - Avoid long construction, financing
 - On-site energy better than hydrogen via pipelines/trucks?
- **Unattended autonomous operation**
 - Automation and robotics, not workers
 - Remote multi-unit monitoring and control centers
- **Nuclear energy as *products*, not *projects***

Illustrative Learning Rates for Cost Reduction

$$C_i = C_1 \times (1 - r)^{\log_2 i}$$

r is the percentage reduction in cost per doubling in cumulative unit deployments

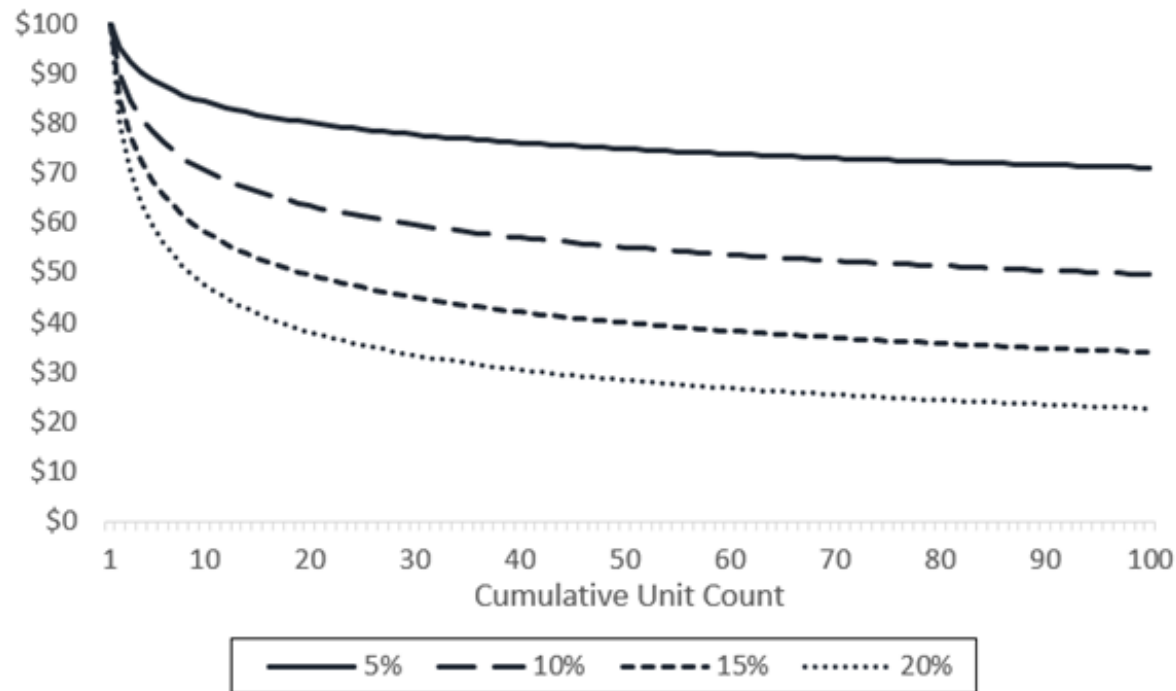

Global onshore wind learning rate r from 1985 to 2015 = **19%** (87% cost reduction cumulatively)

Global solar PV module learning rate r from 1976 to 2015 = **24%** (99% cost reduction cumulatively)

Source for global wind and solar learning rates: Bloomberg New Energy Finance
(<http://cgcan.org/wp-content/uploads/2016/07/Learning-curves-for-wind-PV-BNEF-2016.png>)

Summary for Fission Battery Development

1. What are the markets and customers?

- Many: **Electricity** (regional grid, microgrids, remote communities, military, mines), **heat** (refineries, chemicals, paper, food, commercial, residential), **other** (hydrogen, synthetic hydrocarbon fuels, ammonia, desalination, ...)

2. What is the optimal unit size?

- Wide range, but many industrial facilities require 20 - 200 MW_t (multiple units could be deployed per site, multiple customers)

3. What is the total market opportunity?

- Very large, especially if transition away from fossil must accelerate

4. What is the optimal outlet temperature?

- Many industrial processes require 200 - 750 C



Idaho National Laboratory

Nuclear Hydrogen Futures

Eric Ingersoll

LUCID
CATALYST

January 2021



Zero emissions hydrogen in the transition to a zero emissions energy system—examples

- Today's markets—but clean
 - Competitors: natural gas (SMR) and coal gasification
 - Add to gas networks
- Medium-term direct use (may be substituted later)
 - Heavy trucking, long-distance buses, locomotives
 - Onsite fuel cell cogen
- Long-term direct use (depends on converting end uses)
 - Long-distance aviation
- Feedstock for fuels and chemicals (substitute)
 - Synthetic hydrocarbons
 - Hydrocarbon substitutes, e.g., ammonia

Hydrogen cost drivers



Relationship b/w capacity factor & hydrogen cost

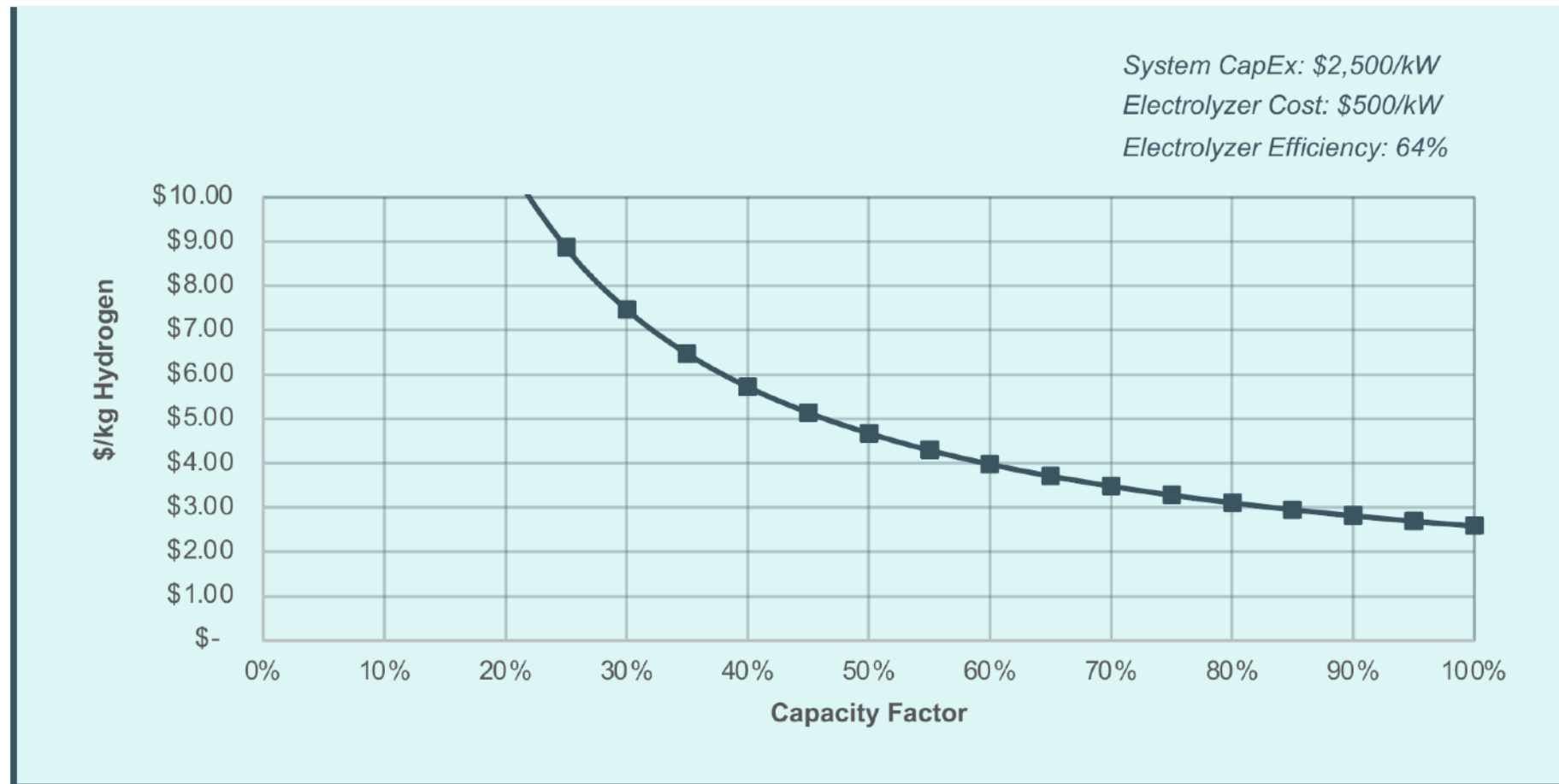

Relationship b/w energy system CapEx & hydrogen cost

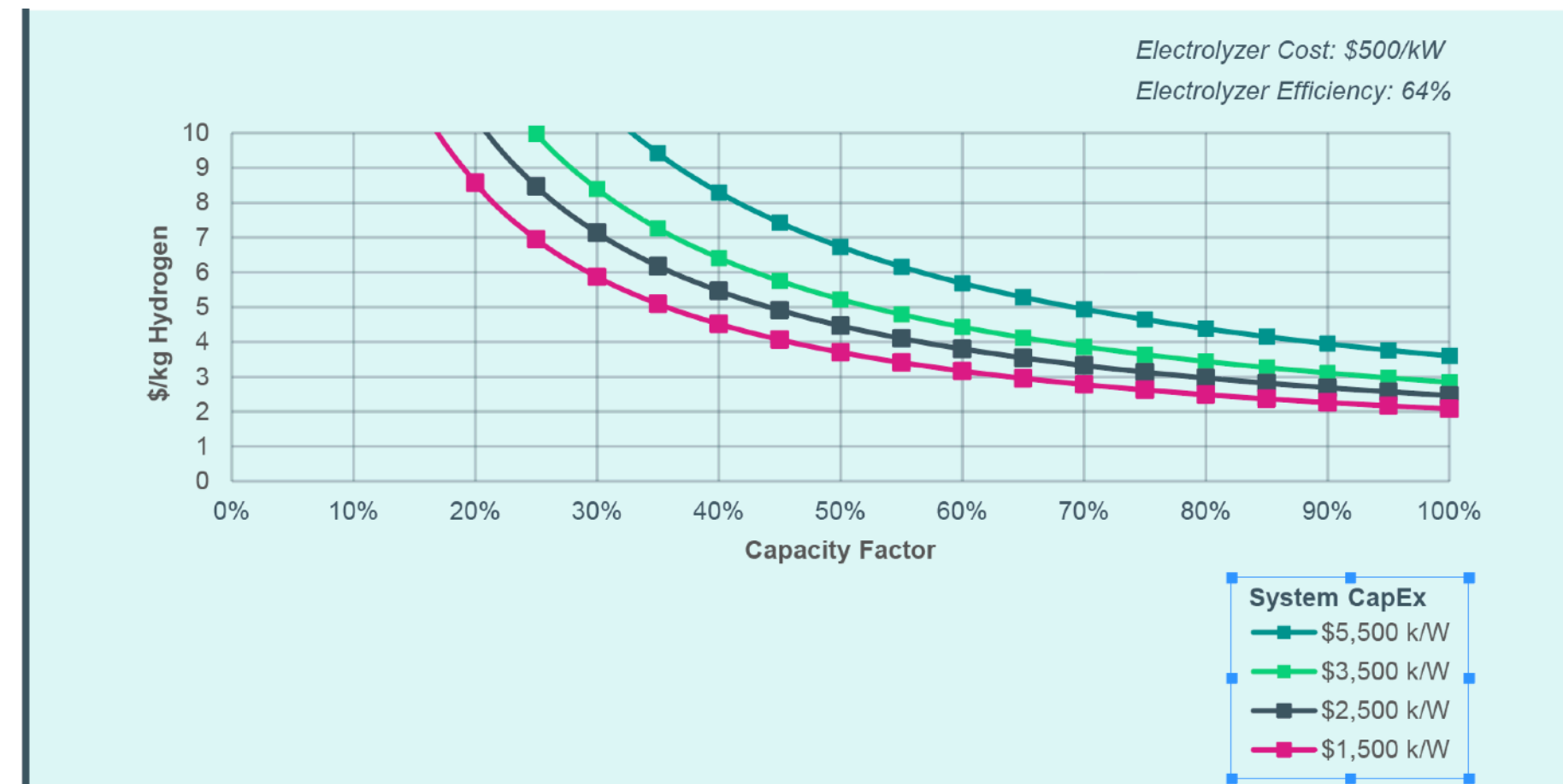

Relationship b/w electrolyzer efficiency & hydrogen cost

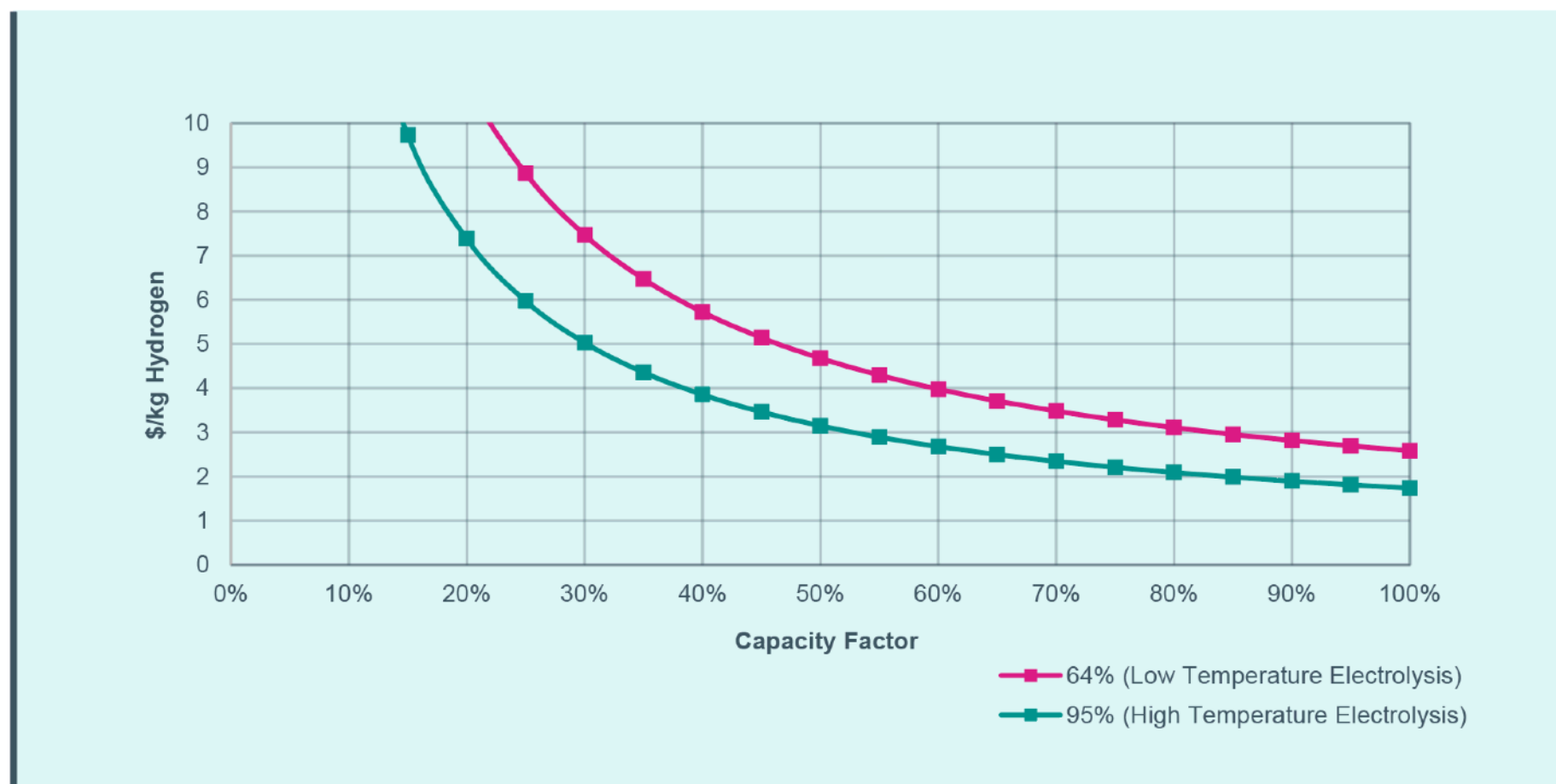

Relationship b/w electrolyzer CapEx & hydrogen cost

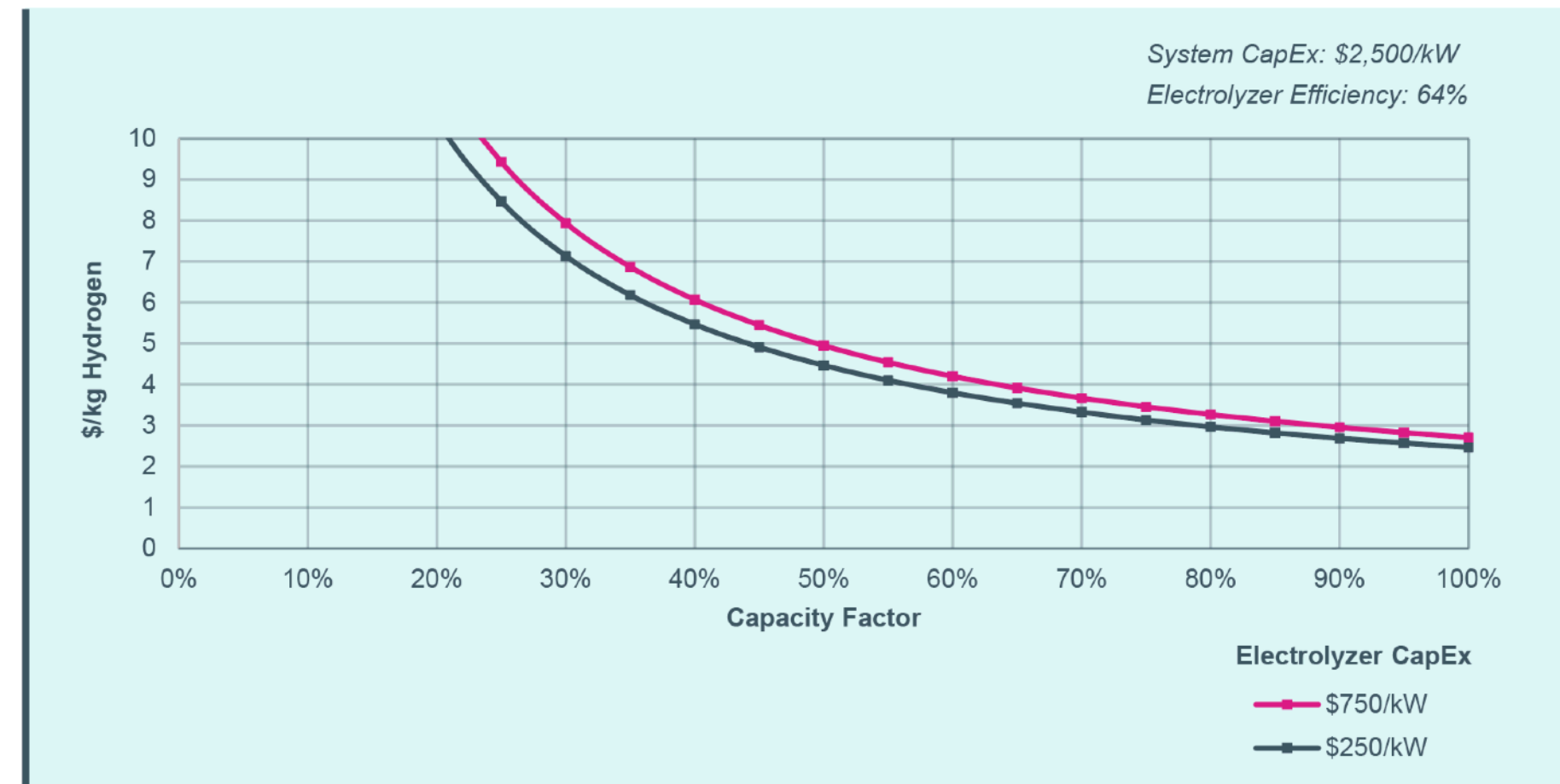

Source: LucidCatalyst, "Missing Link to a Livable Climate: How Hydrogen-Enabled Synthetic Fuels Can Help Deliver the Paris Goals," 2020.

Hydrogen production costs

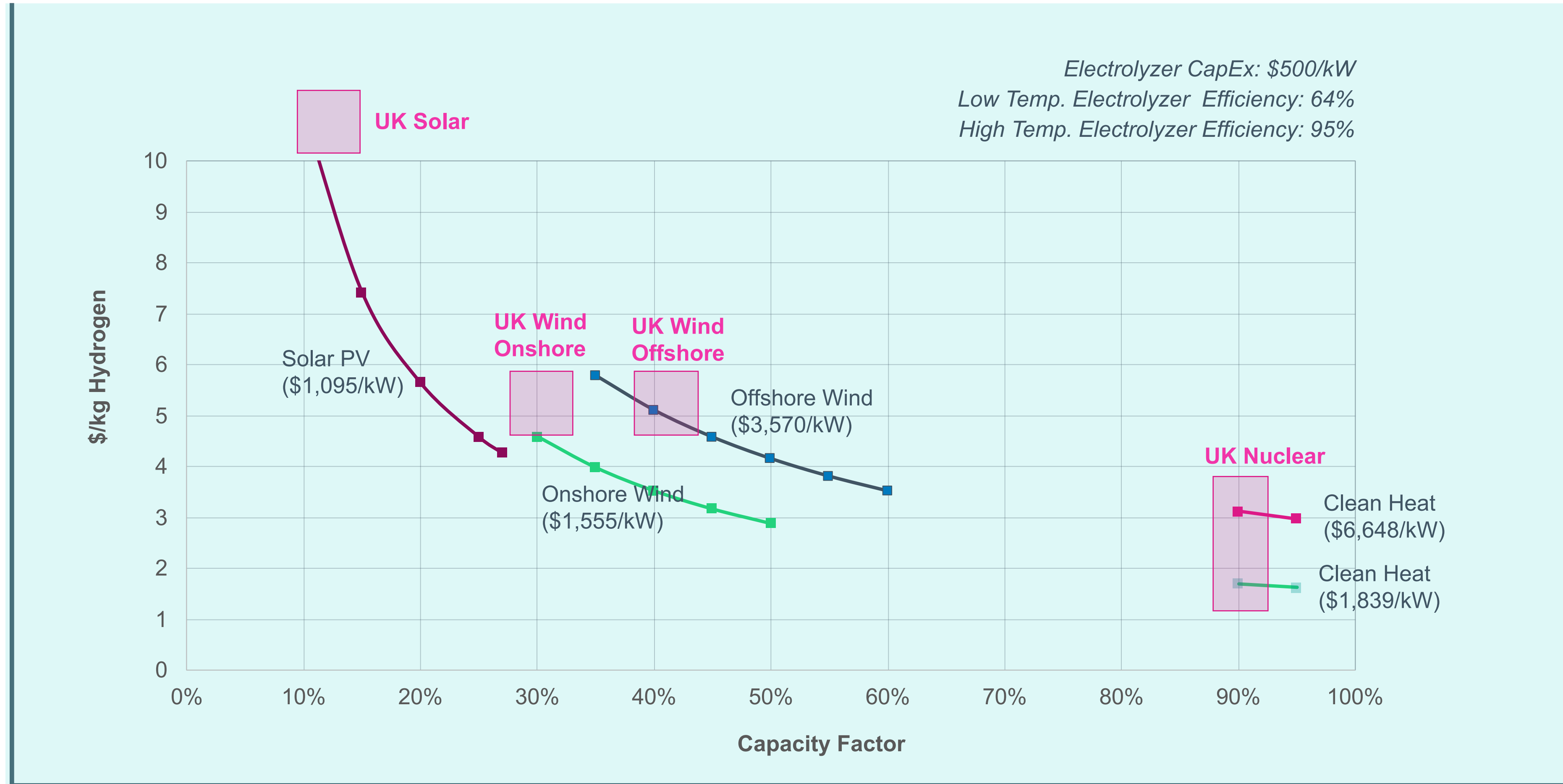

Current hydrogen production costs of different energy technologies in the UK

Source: LucidCatalyst, "Missing Link to a Livable Climate: How Hydrogen-Enabled Synthetic Fuels Can Help Deliver the Paris Goals," 2020.

Target price for clean hydrogen

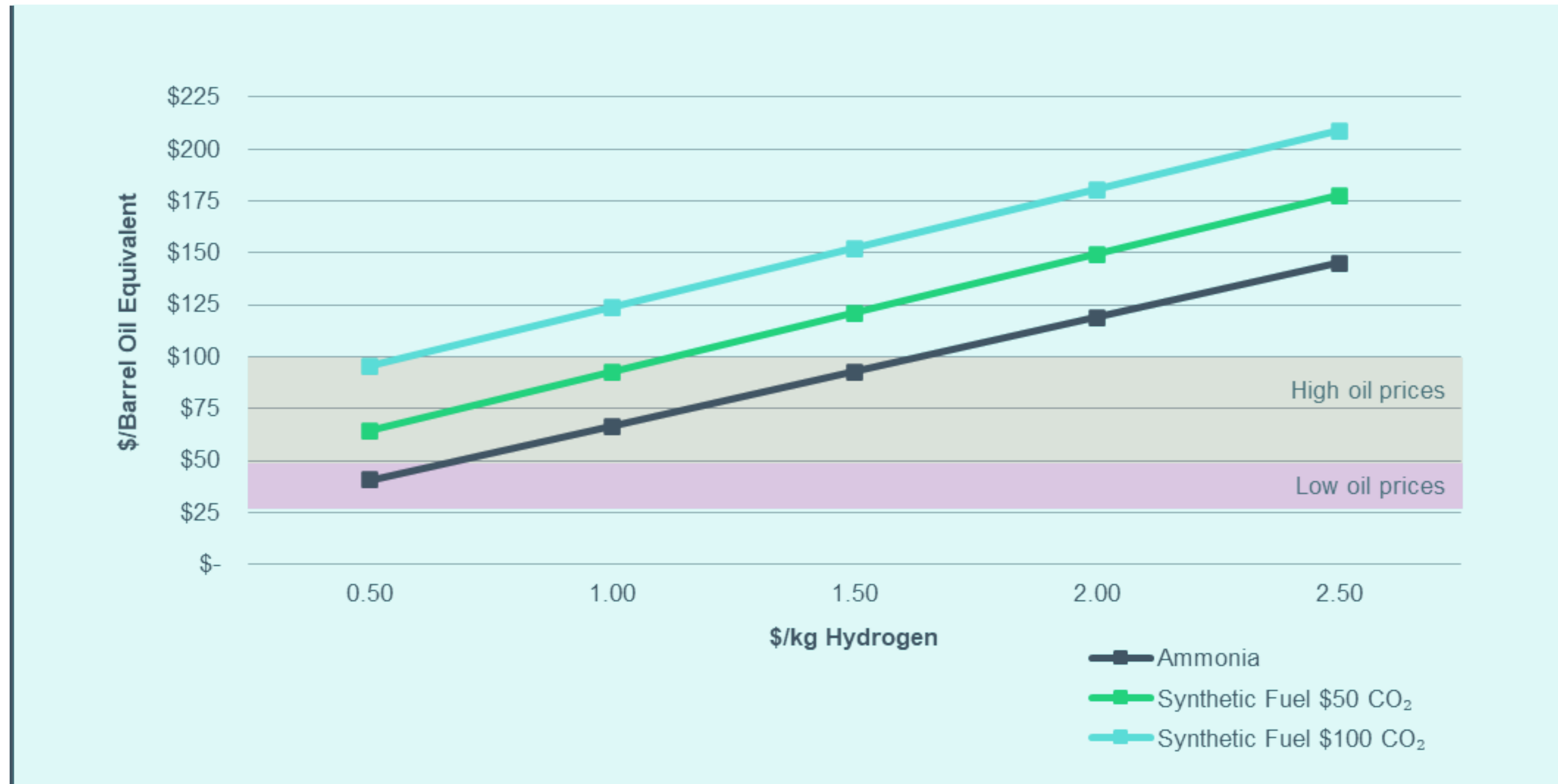

Oil price 'guardrails' of the hydrogen economy (\$0.50–1.50/kg hydrogen)

Source: LucidCatalyst, "Missing Link to a Livable Climate: How Hydrogen-Enabled Synthetic Fuels Can Help Deliver the Paris Goals," 2020.



Key innovations for low cost hydrogen made from nuclear energy

- Requires very low cost energy as input
- Exportable commodity, not tied to local grid scale demand
 - Enables much larger projects
 - A refinery, not a power plant
- Manufacturing-based delivery model
 - Bring the factory to the project: Gigafactory
 - Bring the project to the factory: Shipyard manufacturing

Gigafactory



Hydrogen/Synfuel
Gigafactory

Source: LucidCatalyst

Ship-manufactured ammonia platform



Ammonia bunker offloading ammonia from production platform



Shipyard manufacturing of fuels production platforms



Source: LucidCatalyst

Projected hydrogen production cost in 2030

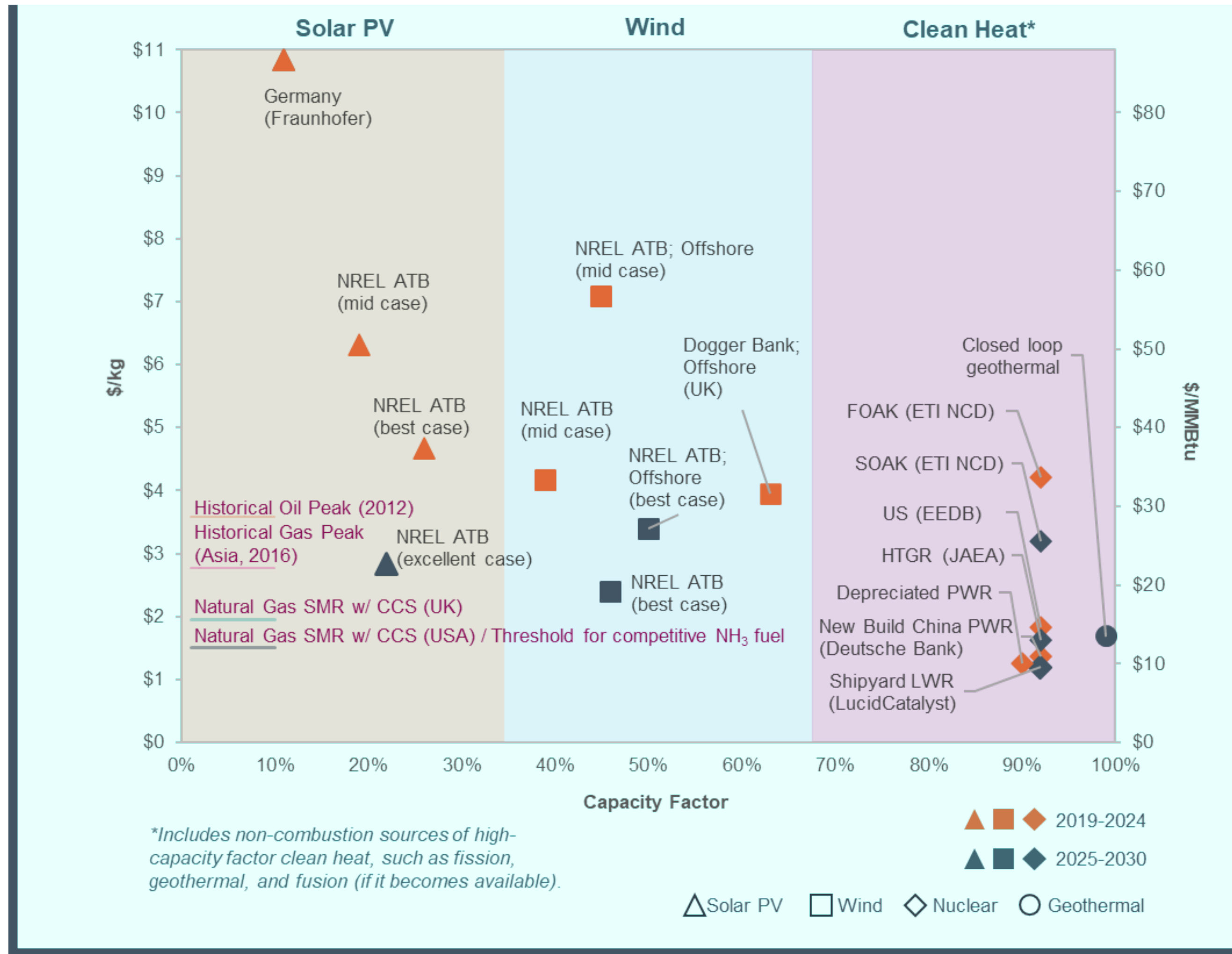

Cost of hydrogen production from different energy technologies in the real world now and in 2030

Source: LucidCatalyst, "Missing Link to a Livable Climate: How Hydrogen-Enabled Synthetic Fuels Can Help Deliver the Paris Goals," 2020.

Projected hydrogen production cost in 2050

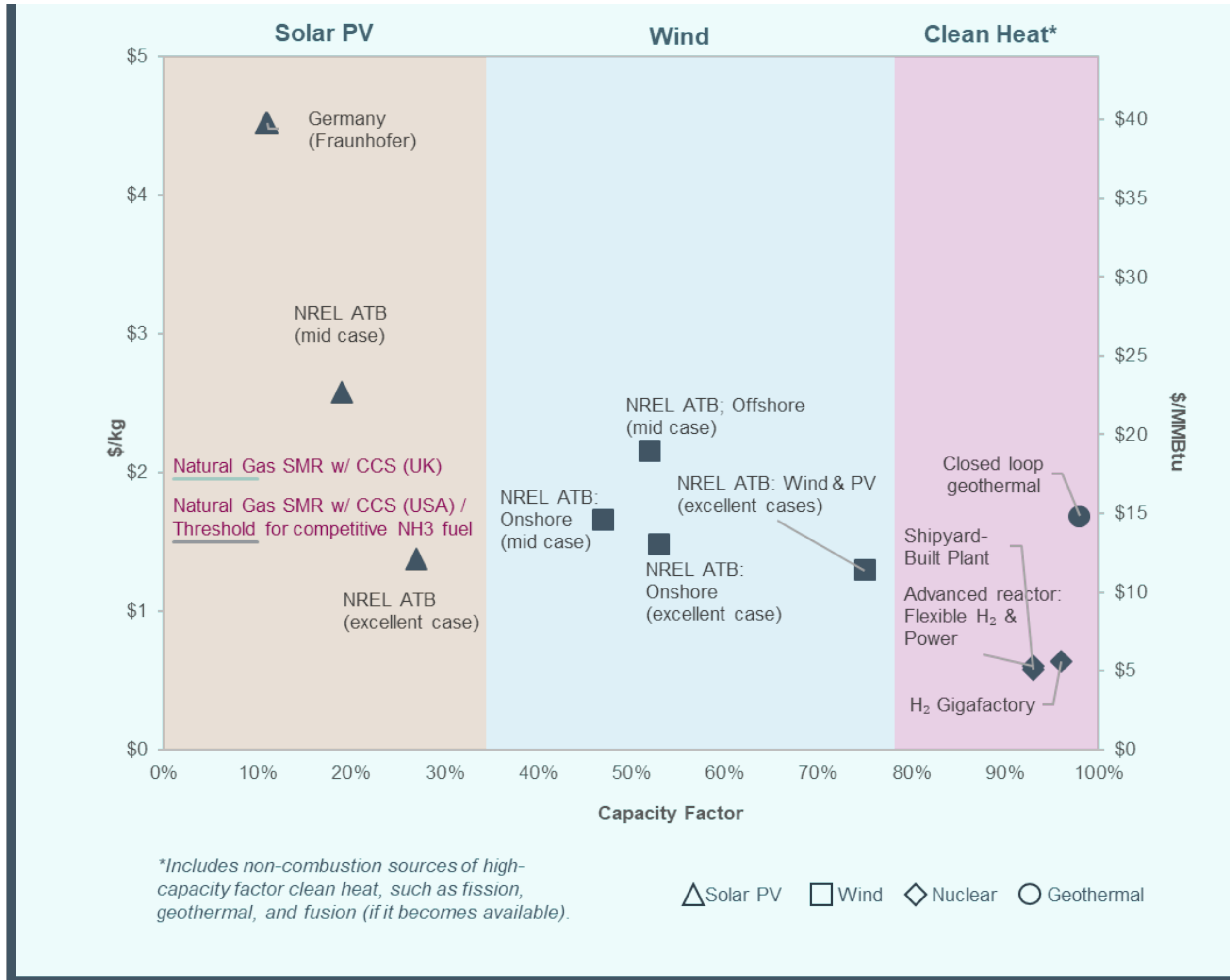

Projected cost of hydrogen production from different energy technologies in 2050

Source: LucidCatalyst, "Missing Link to a Livable Climate: How Hydrogen-Enabled Synthetic Fuels Can Help Deliver the Paris Goals," 2020.



Nuclear batteries are unlikely to compete with gas or electric grid supplied energy

- Bulk electricity and hydrogen will get very cheap
- Zero emissions ammonia will flatten the global variation in hydrogen prices
 - \$250–200/tonne ammonia production cost (forthcoming EPRI study)
 - \$13.44–10.75/GJ or \$84.40-67.50/bbl-finished product
 - \$48.40–38.7/MWt
 - Fuel production platforms can be close to end-use markets
 - Longer-distance delivery costs should drop to match LNG transportation costs ~\$1/GJ
 - Ammonia pipelines cost less than natural gas and have higher energy density
- Opportunity: places where you cannot deliver bulk energy easily
- What about a small ammonia plant?

LucidCatalyst delivers strategic thought leadership to enable rapid decarbonization and prosperity for all.

Eric Ingersoll

eric.ingersoll@lucidcatalyst.com

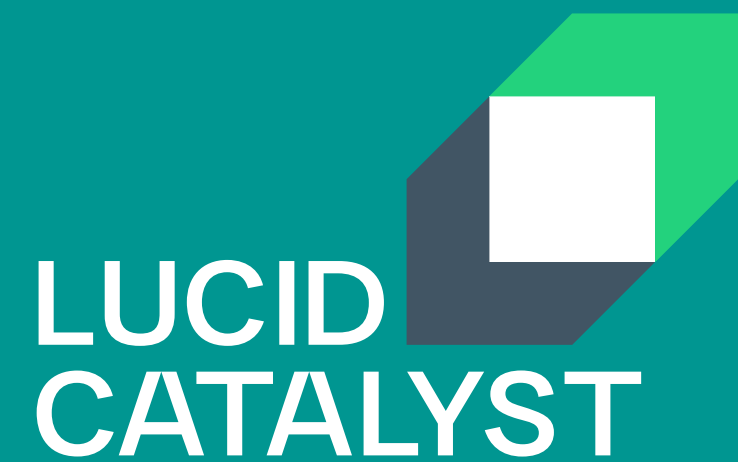



Fission Battery Initiative Workshop – Maritime Perspective

Gareth Burton | January 13 2021



© 2021 American Bureau of Shipping. All rights reserved

Discussion Items

- Introduction to ABS
- Overview of the Marine Industry
- Safety Network in the Marine Industry
- Current Industry Drivers

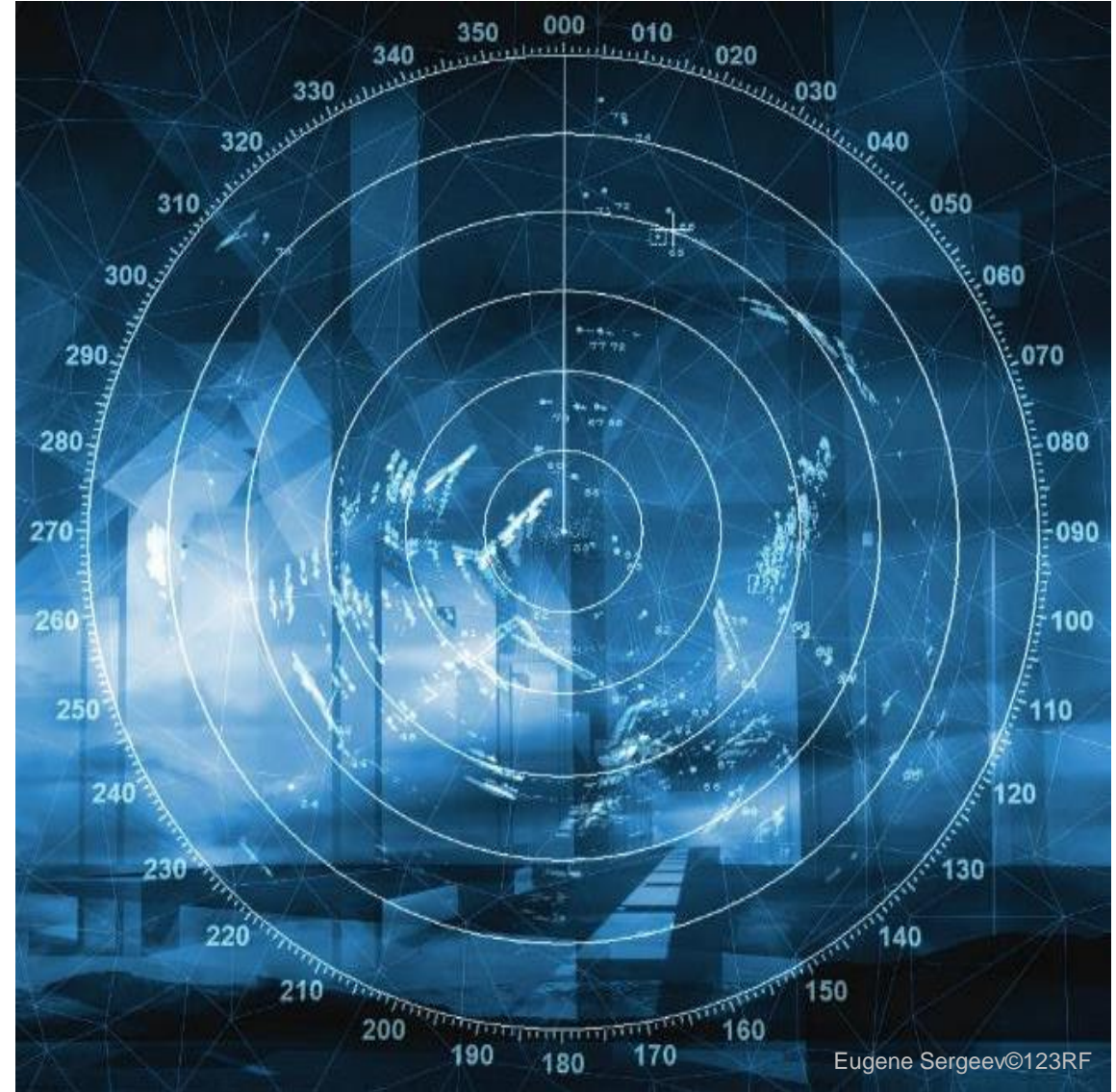

Introduction to ABS

- ABS Organization
- ABS Mission
- Standards Development



Introduction to ABS

- Not-for-profit classification society
- Headquarter: Houston, Texas
- Independent arbiters of standards
- Achieved by establishing and administering standards known as rules for marine vessels and structures
 - Design
 - Construction
 - Operational Maintenance
- Worldwide presence at ports, shipyards, and manufacturing facilities
 - 200 overs in 70 countries



Marine Standards

- Class Requirements
- Guidance Documents
- Focus
 - Practical
 - Authoritative
 - Impartial



Overview of Marine Industry

- Industry Size, Vessel Types
- Operating Profile, Power Requirements
- Power Options
- Nuclear Power in Marine



Maritime Industry: Industry Size

SELF-PROPELLED SHIPS

World Fleet

99,031 SHIPS **2097.1** Million Dwt

Cargo Carrying Ships

61,384 SHIPS **2012.7** Million Dwt



MARITIME

- Bulk Carriers
- Tankers
- Containerships
- Passenger, Ferries, Ro-ro



OFFSHORE

- Exploration
- Production
- Offshore Support



GAS

- FLNG (Floating Liquefied Natural Gas)
- FSRU (Floating Storage & Regassification Unit)



Navy

- Combatants
- Auxiliaries

Maritime Industry: Vessel Types

Bulk Carriers: Carry dry cargo in bulk, such as ore, grain, or coal



Vessel Deadweight (DWT)	Category of Bulk Carrier
$\geq 200K$	Very Large Ore Carrier (VLOC) Very Large Bulk Carrier (VLBC)
120K-200K	Capesize
83K-120K	Post Panamax
80K-83K	Kamsarmax
65K-80K	Panamax
40K-65K	Handymax
10K-40K	Handysize
$< 10K$	Small Bulker

Tankers: Carry liquid such as crude oil



Vessel Deadweight (DWT)	Category of Tanker
$\geq 200K$	Very Large Crude Carrier (VLCC)
125K-200K	Suezmax
85K-125K	Aframax
55K-85K	Panamax
25K-55K	Medium Range (MR)
$< 25K$	Short Range (SR)
$\geq 10K$	Handysize
$< 10K$	Small Tanker



Crude Oil Tanker: Operating Profile

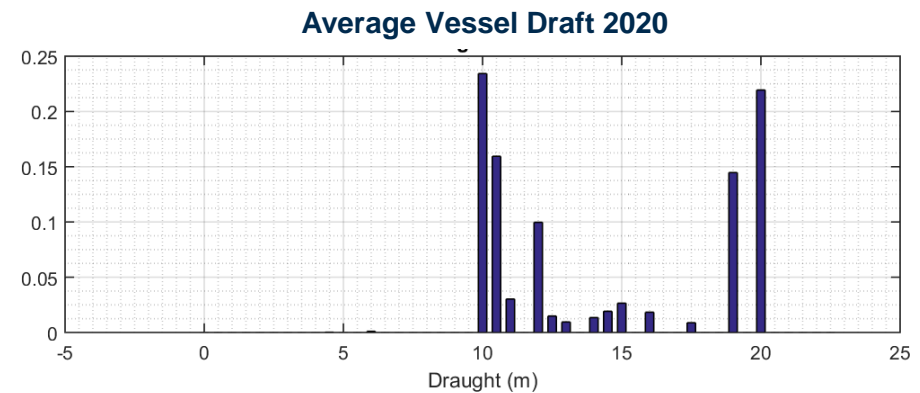
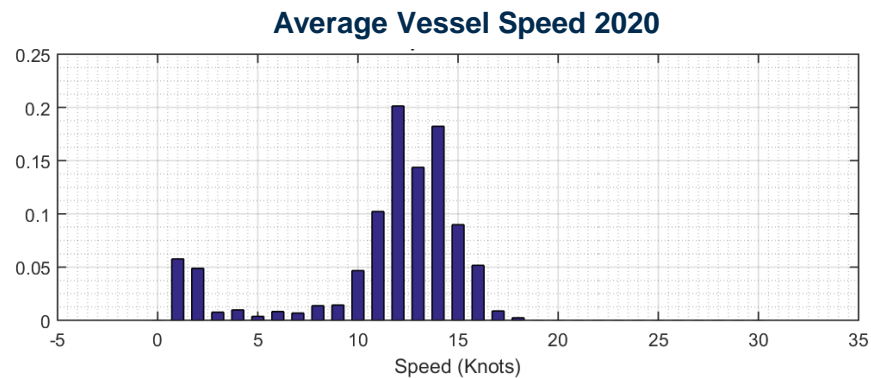
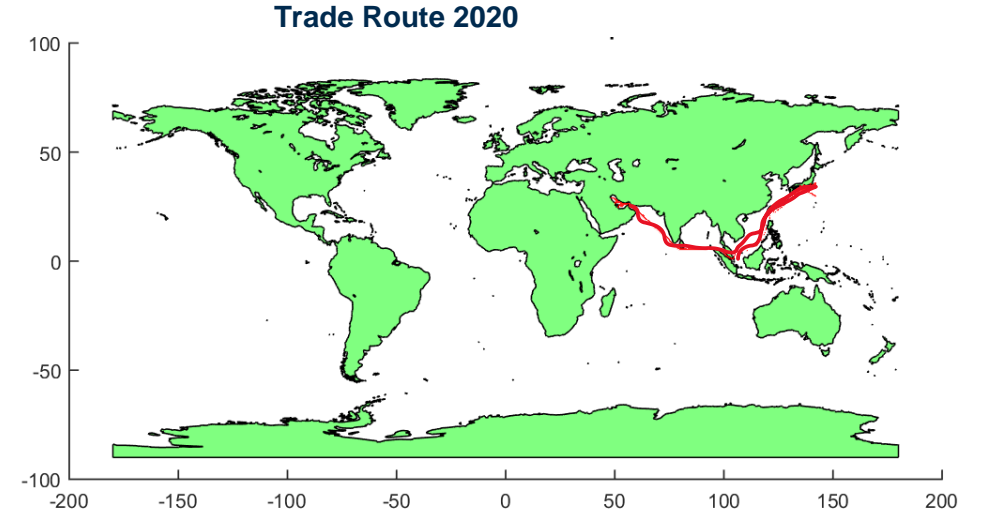

Crude Oil Tanker: Power Arrangements

Propulsion Power:

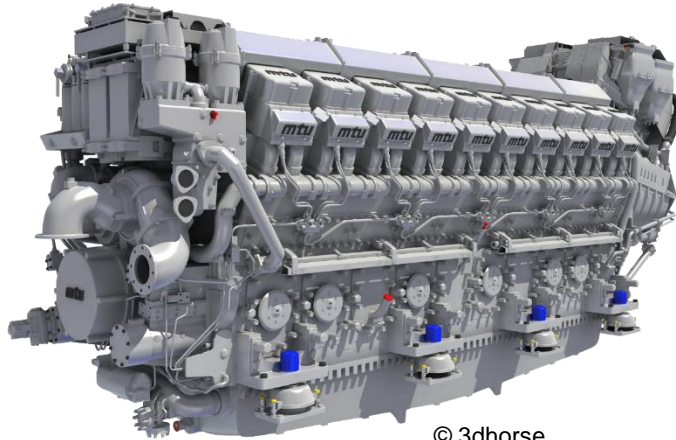

© 3dhorse

Installed Propulsion Power	
Maximum Continuous Rating (kW)	26,900
# of Cylinders	10
Engine Cycle	2 Stroke
Revolutions (RPM)	75.8

Other Shipboard Loads:



	At Sea	Maneuvering	Cargo Ops. Loading	Cargo Ops. Unloading	Harbor	Emergency
Average Continuous Load (KW)	868	1,608	1,136	1,573	660	118
Intermittent Load (KW)	259	290	256	295	266	0
Diversity Factor (%)	40	40	40	40	40	40
Equivalent Intermittent Load (KW)	104	116	102	118	106	0
Total Required Power (KW)	972	1,724	1,238	1,691	766	118
Generating Capacity (KW)	1,150	2,300	2,300	2,300	2,300	300
Notes	1 GEN.	2 GEN.	2 GEN.	2 GEN.	2 GEN.	1 GEN.
Generator Loading	0.84	0.75	0.54	0.74	0.33	0.39

Platform Support Vessel: Power Arrangements

- Diesel Electric
- Total Installed Power: 7600 KW
- Propulsion
 - 2 x Bow Thrusters
 - 2 x Azimuth Thrusters

Power	
Propulsion	Diesel Electric
Main Engines	4 x 1900 KW
Main Generators	4 x 480VAC, 2282 KVA
Total Installed Power	7,600 KW
Emergency Generators	2 x 470KW

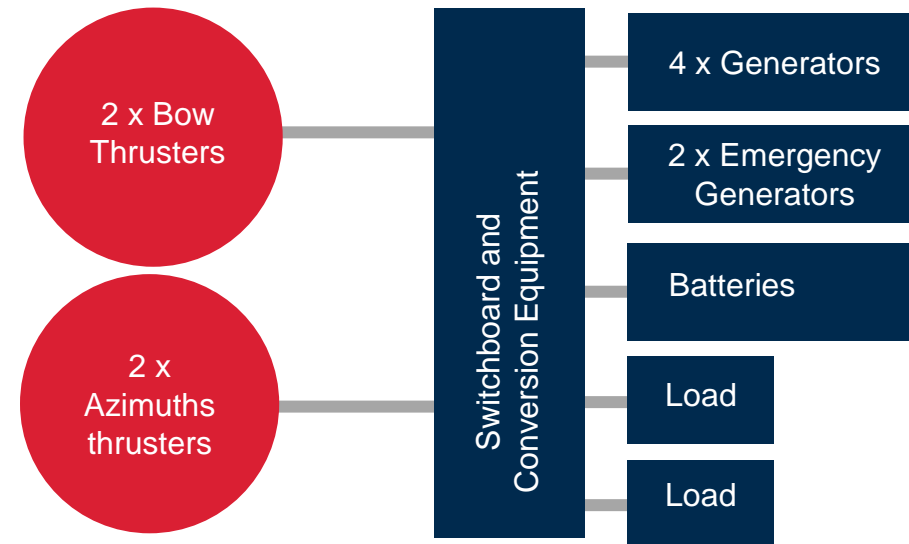
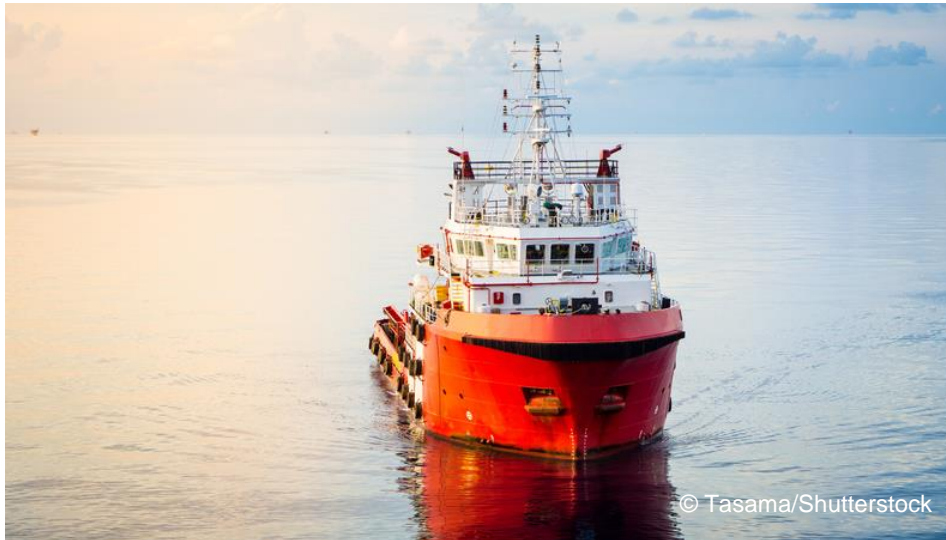

Power Options

- Internal Combustion Engine
- Diesel Electric
- Steam turbine
- Gas Turbine
- Hybrid Systems (Battery)
- Fuel Cell
- Wind Propulsion
- Solar
- Nuclear

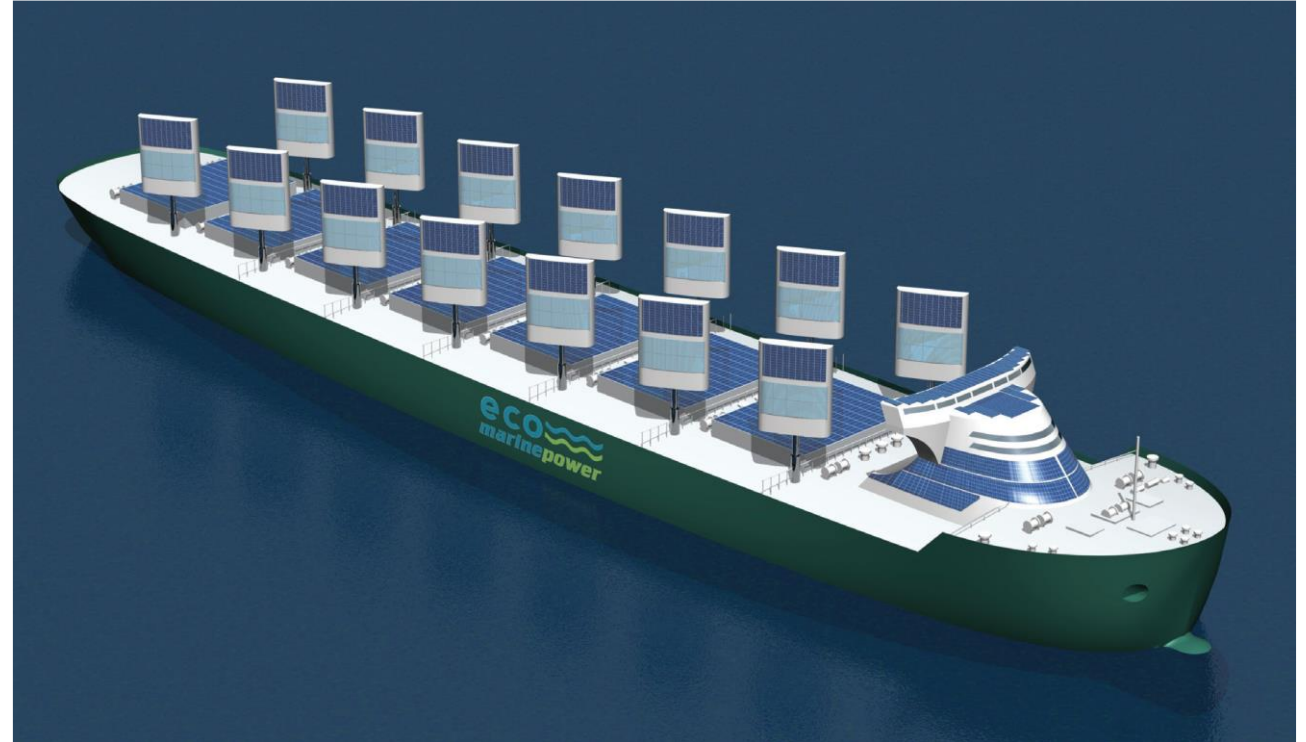

Nuclear Maritime History

- United States
 - 1940: Research on application in marine propulsion
 - 1953: The first test reactor
 - 1955: First nuclear submarine, USS Nautilus (SSN-571)
 - 1962: U.S. Navy 26 nuclear submarines operational and 30 under construction
 - 1959: N.S. Savannah, 1st nuclear-powered merchant vessel
- USSR / Russia
 - 1955: 1st Soviet nuclear submarine, K-3 Leninsky Komsomol
 - 1957: World's 1st nuclear icebreaker, "Lenin"
 - Current: Ice Breaker fleet



NS (Nuclear Ship) Savannah, enroute to the World's Fair in Seattle, 1962

Current Military Use of Nuclear Power	
US Navy	<ul style="list-style-type: none">• 73 Submarines (55 Attack, 18 Ballistic/ Guided Missile)• 11 Aircraft Carriers
Russian Navy	<ul style="list-style-type: none">• 21 Submarines (13 Attack, 8 Ballistic/ Cruise Missile)• 1 Battlecruiser
China	<ul style="list-style-type: none">• 14 Submarines (9 Attack, 5 Ballistic)
British Navy	<ul style="list-style-type: none">• 10 Submarines (6 Attack, 4 Ballistic)
France	<ul style="list-style-type: none">• 9 Submarines (5 Attack, 4 Ballistic)• 1 Aircraft Carrier
Indian Navy	<ul style="list-style-type: none">• 1 Submarine

Safety Network in the Maritime Industry

- Stakeholders
- International Maritime Organization



Maritime Safety Network

- Multiple Stakeholders



International Maritime Organization (IMO)



- Part of the United Nations – members are representative of individual governments
- Commercial and other interested organizations (IACS) have observer status
- Conventions must be adopted by individual flag states within their national laws
- IMO Conventions:
 - LOAD LINE: amount of cargo a vessel may safely carry
 - TONNAGE: the carrying capacity of a ship based on volume
 - SOLAS (Safety of Life at the Sea): construction, communications, lifesaving, fire protection, firefighting
 - MARPOL (Marine Pollution): pollution prevention from onboard lubricants, cargoes or emissions

Current Industry Drivers

- Sustainability Focus
- Alternative Fuels



Industry Drivers

- **Regulatory:** IMO policies are requiring reduced carbon and GHG emissions
- **Social:** Societal pressures on companies to operate sustainably in all aspects
- **Financial:** Requiring sustainability initiatives to reduce long-term risk in investments
- **Corporate Governance and Shareholders:** Board rooms are pushing for targeted strategies to reduce emissions
- **Charterers:** Looking for assurance that vessels will be compliant and as efficient as possible
- **Other Stakeholders:** Regional Authorities, Insurers, brokers, etc.

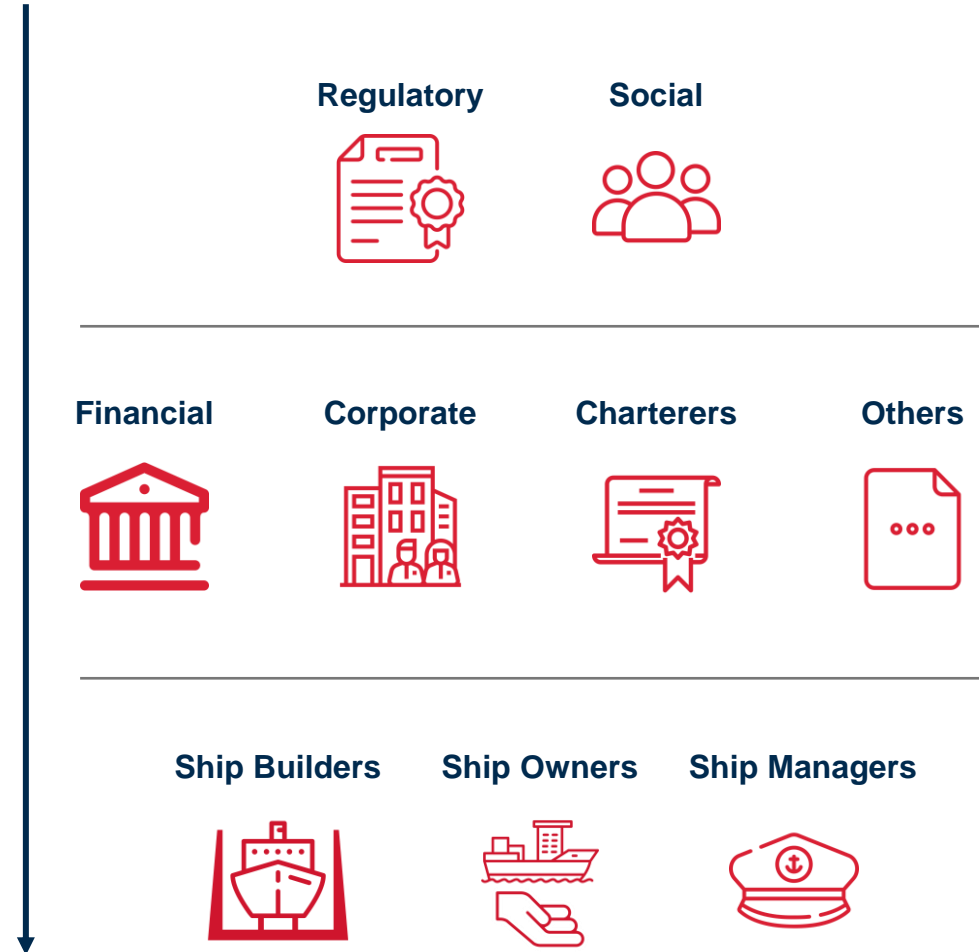

IMO Strategy for Reduction of GHG Emissions from Shipping

- IMO initial strategy set ambitious goals for future pollution reduction targets compared to 2008 levels:
 - Reduce carbon intensity by 40% by 2030
 - Reduce carbon intensity by 70% by 2050
 - Reduce GHG emissions 50% by 2050

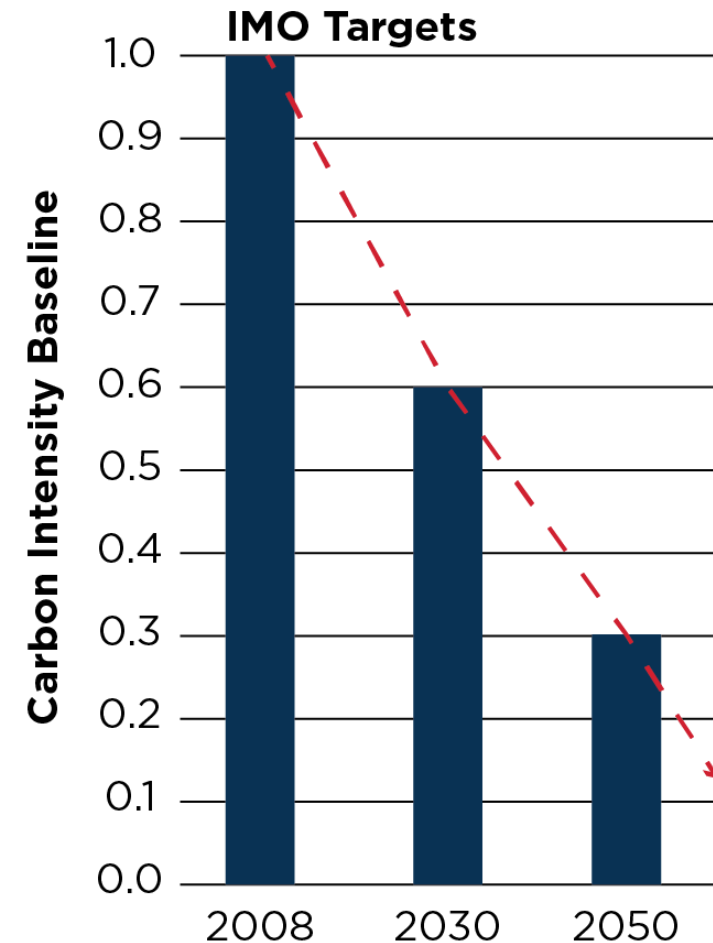

Decarbonization Solutions

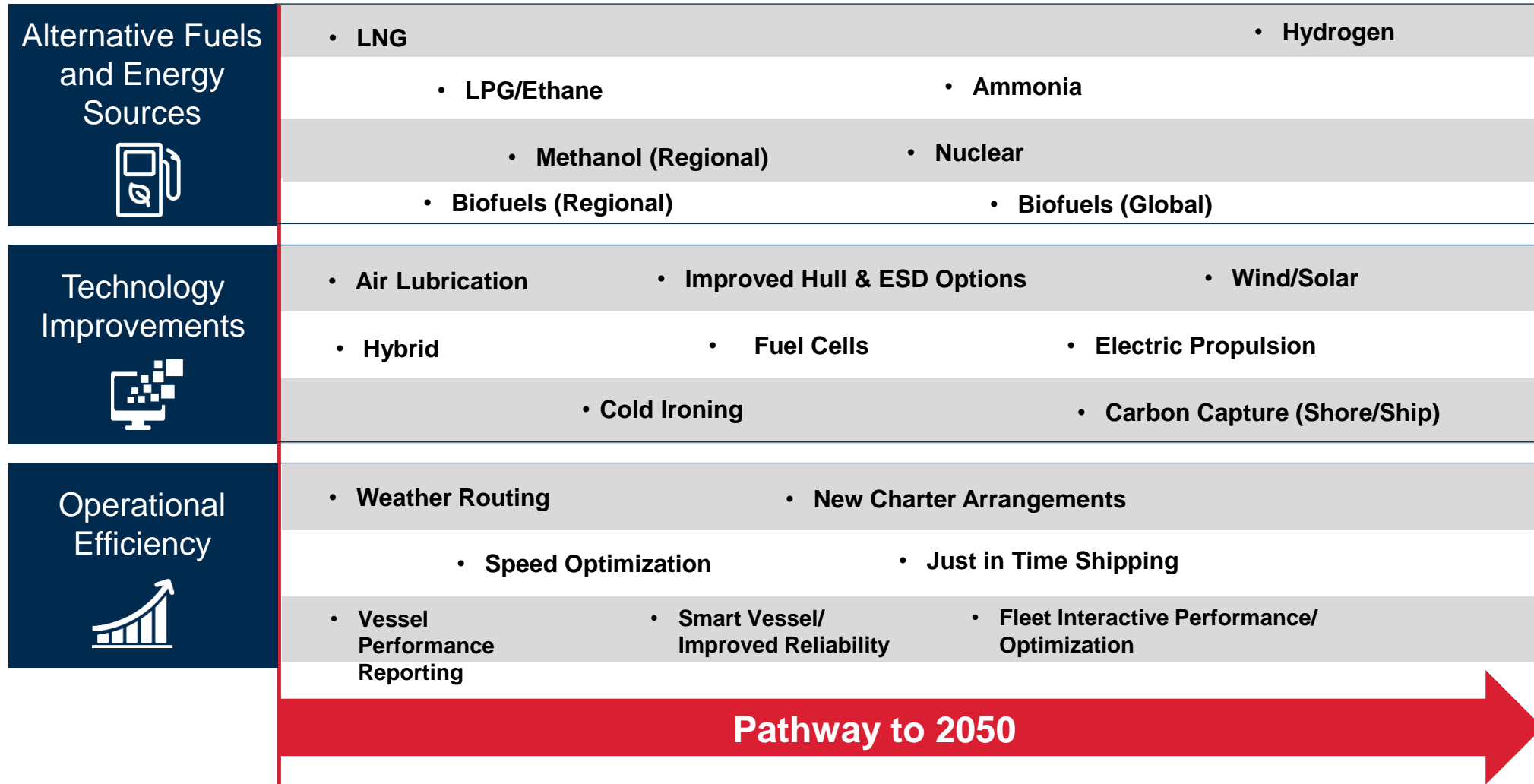

Alternative Fuels/Energy Sources with GHG Reduction Potential

Fuel Type	Infrastructure	Security of Supply	Energy Density	CO ₂	SO _x	Safety
Heavy Fuel Oil	●	●	●	○	○	●
Marine Diesel	●	●	●	○	◐	●
LNG	◐	●	◐	◐	●	◐
LPG	◐	◐	◐	◑	●	◐
Methanol (from Methane)	◐	◐	◑	◑	●	◐
Methanol (from biomass)	◑	◑	◑	●	●	◐
Ammonia (from methane)	◐	◐	◑	◑	●	◐
Ammonia (from renewable)	◑	◑	◑	●	●	◐
Hydrogen (from methane)	◑	◐	◑	◑	●	◐
Hydrogen (from renewable)	○	◑	◑	●	●	◐
Biofuels	◑	◑	●	◐ ●	●	◐

Notes:

- **Infrastructure** refers to existing bunkering infrastructure or facilities that can be adapted to support bunkering (e.g. import/export terminals)
- **Security of supply** refers to the availability of sufficient global production to meet significant demand from the marine sector for bunkers
- **Energy density** refers to the volumetric energy content of the fuel and on-board storage requirements
- **CO₂ and SO_x** refers to impact on emissions
- **Safety** refers to handling, storage and consumption risks

Source: ABS/MSI study





THANK YOU

www.eagle.org

Liquid Biofuels and Energy Markets

Bruce E. Dale
University Distinguished Professor
Michigan State University. East Lansing, MI

**Workshop:
Markets and Economic Requirements for Fission Batteries
and Other Nuclear Systems**

January 13 and Jan 27, 2021

Outline

- Market and Biomass Resource Base for Liquid Fuels
- Ethanol (corn and sugar cane) Biofuels
- Cellulosic Biofuels
- Paper, Pulp and Liquid Fuels
- Conclusions

Market and Biomass Resource Base for Liquid Fuels

Liquid Fuels Are Central to the Economy

Bigger and More Difficult to Decarbonize than Electricity

Estimated U.S. Energy Consumption in 2019: 100.2 Quads

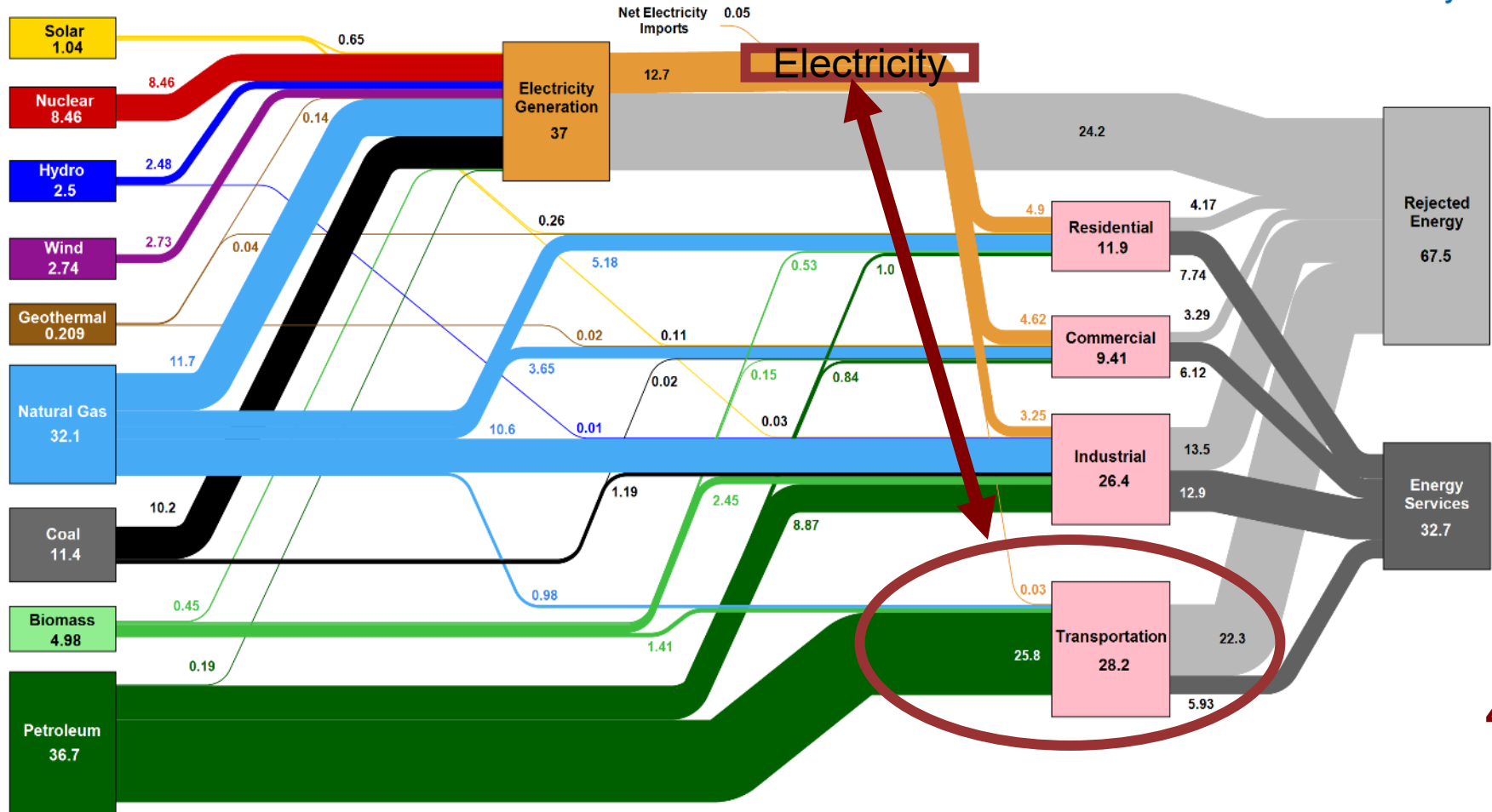

Bioenergy Contribution in 2050: Five Low-Carbon Energy Scenarios Suggest it is about 25% of Global Energy Needs

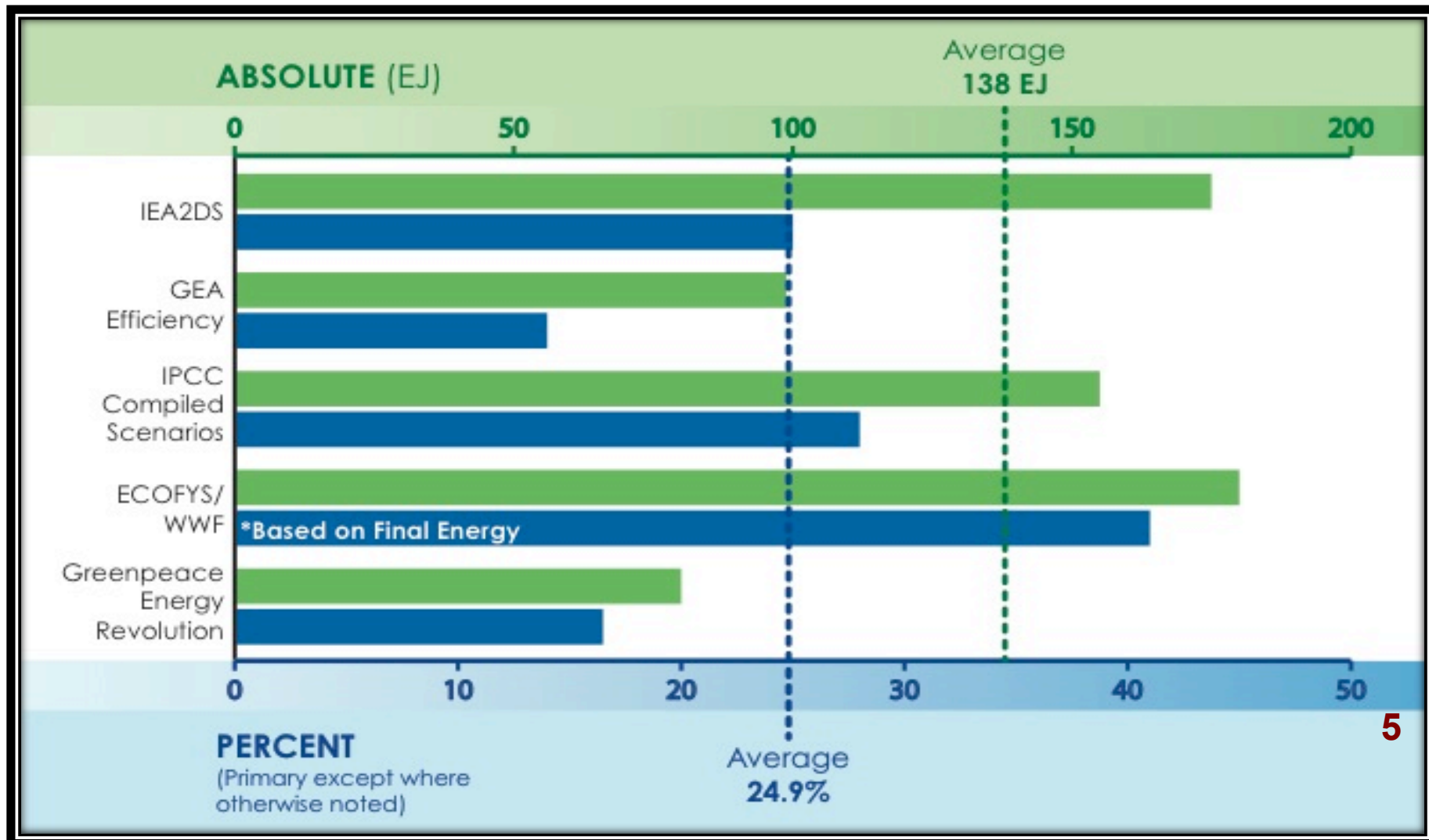

External Energy Sources Can Double Liquid Fuel Yields Per Ton of Biomass

Choice: Burn Biomass or Supply External Energy Heat/H₂ for Biorefinery?



Biomass

Energy

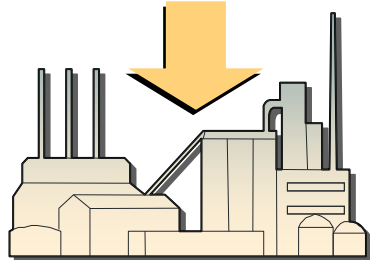

Fuel Factory

Liquid Fuels

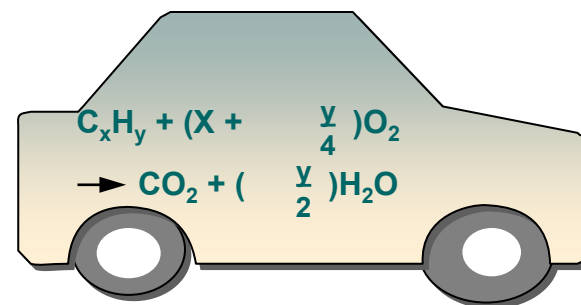

Cars, Trucks, and Planes

Atmospheric Carbon Dioxide

Biomass Is Both an Energy Source & a Carbon Source

- If external energy sources are used, liquid fuels per ton of biomass can be doubled
- *Thus reducing biofuel land footprint by 2x*
- Multiple biofuels processing options available with different energy requirements
- Preferred choices driven by economics
- ***External energy inputs could be in excess of 10% of the total U.S. energy consumption***

Market A

Ethanol (corn & sugar cane) Biofuels

Current Biofuels Industry
United States, Canada and Brazil

Ethanol Plants (Modified Beer Brewing) Produce Multiple Products

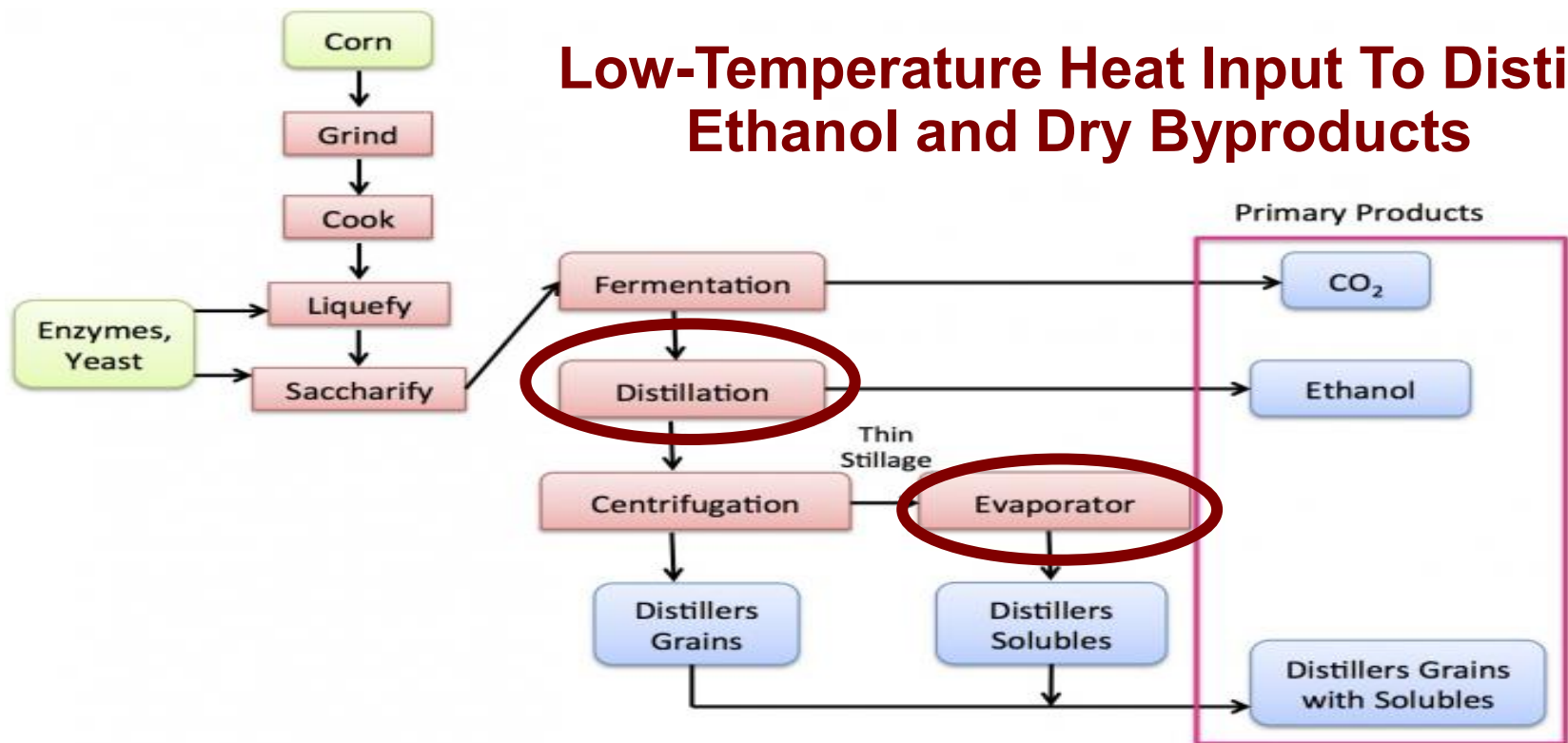

<https://www.e-education.psu.edu/egee439/node/673>; Credit: Caroline Clifford

Energy Inputs for Ethanol Production

FIGURE 5: ENERGY USES IN A TYPICAL ETHANOL PLANT

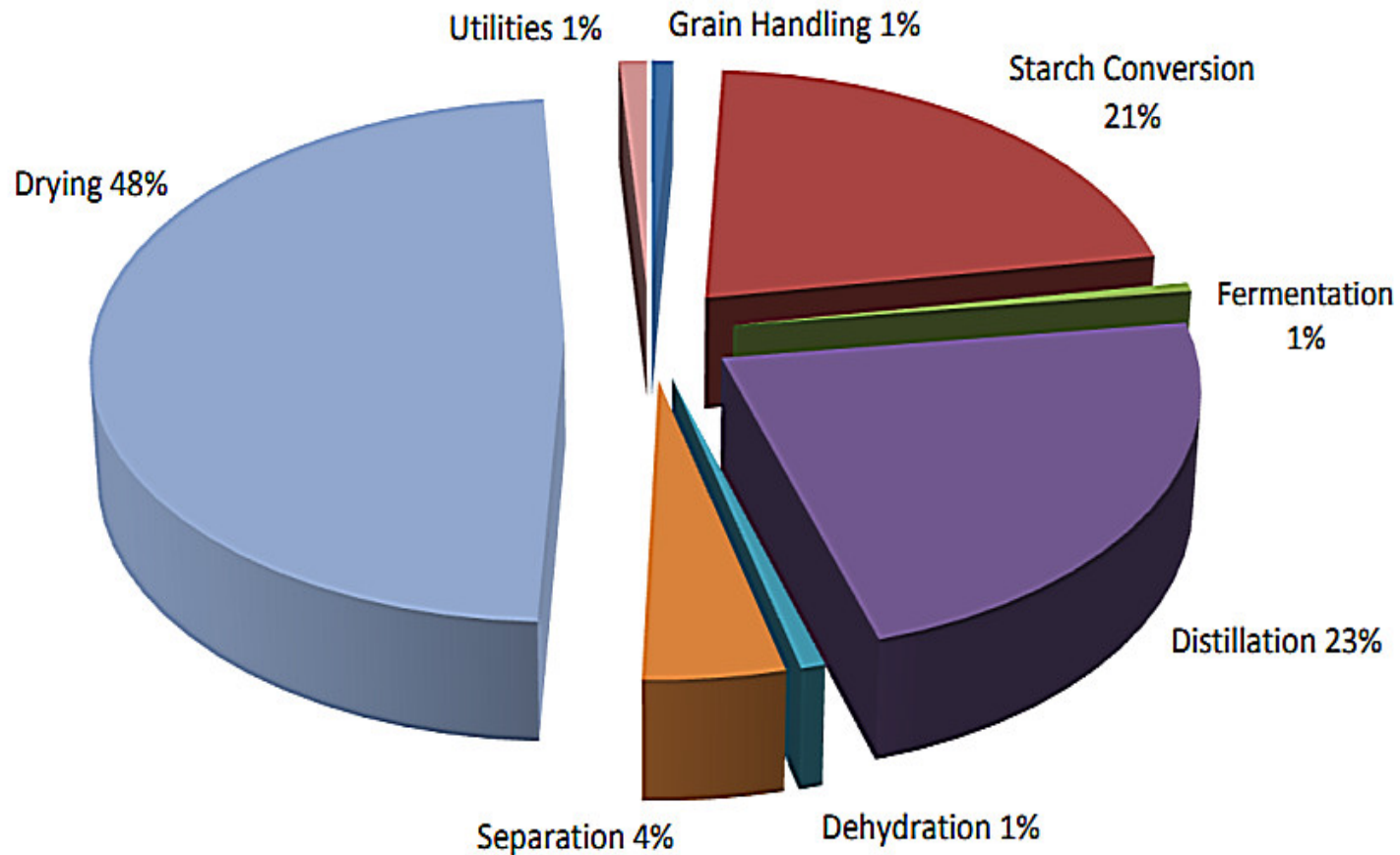

Corn Ethanol Plant Heat Input ~90 MWt (per 100 MM gal/year plant)

U.S. Ethanol Plants

As of October 2012

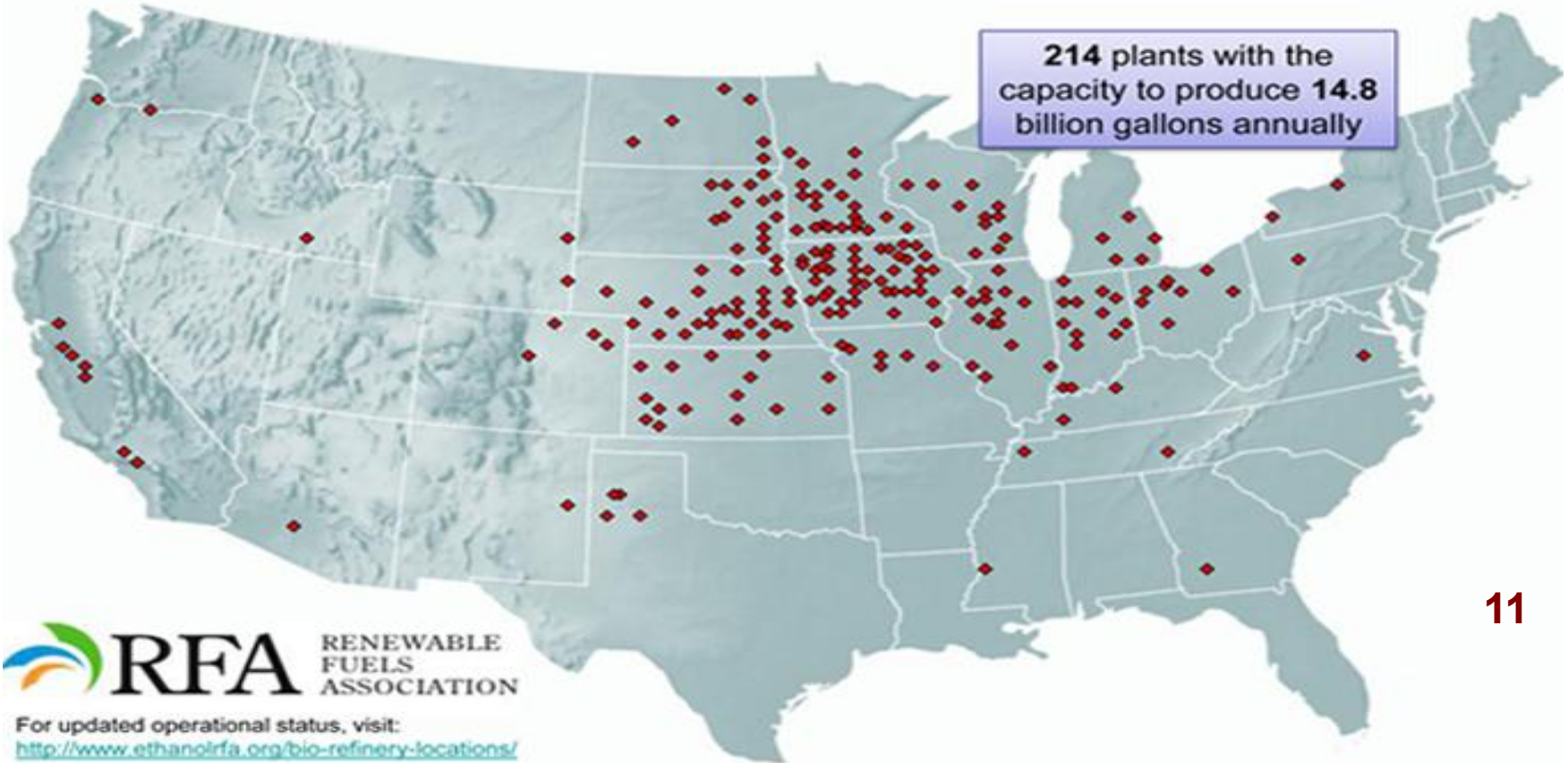

Market B

Cellulosic Biofuels

Objective: Convert All Carbon In Biomass To Drop-In Hydrocarbon Fuels (Gasoline, Diesel & Jet)

Biorefineries Must Compete Head On with Oil Refineries on Scale and Flexibility

Required properties:

- Accept variable feedstocks & produce variable products over time--requires complex flowsheets (right)
- Massive economies of scale—not competitive at small scale
- **Integrated economic refinery input of 250,000 barrels of oil or larger**

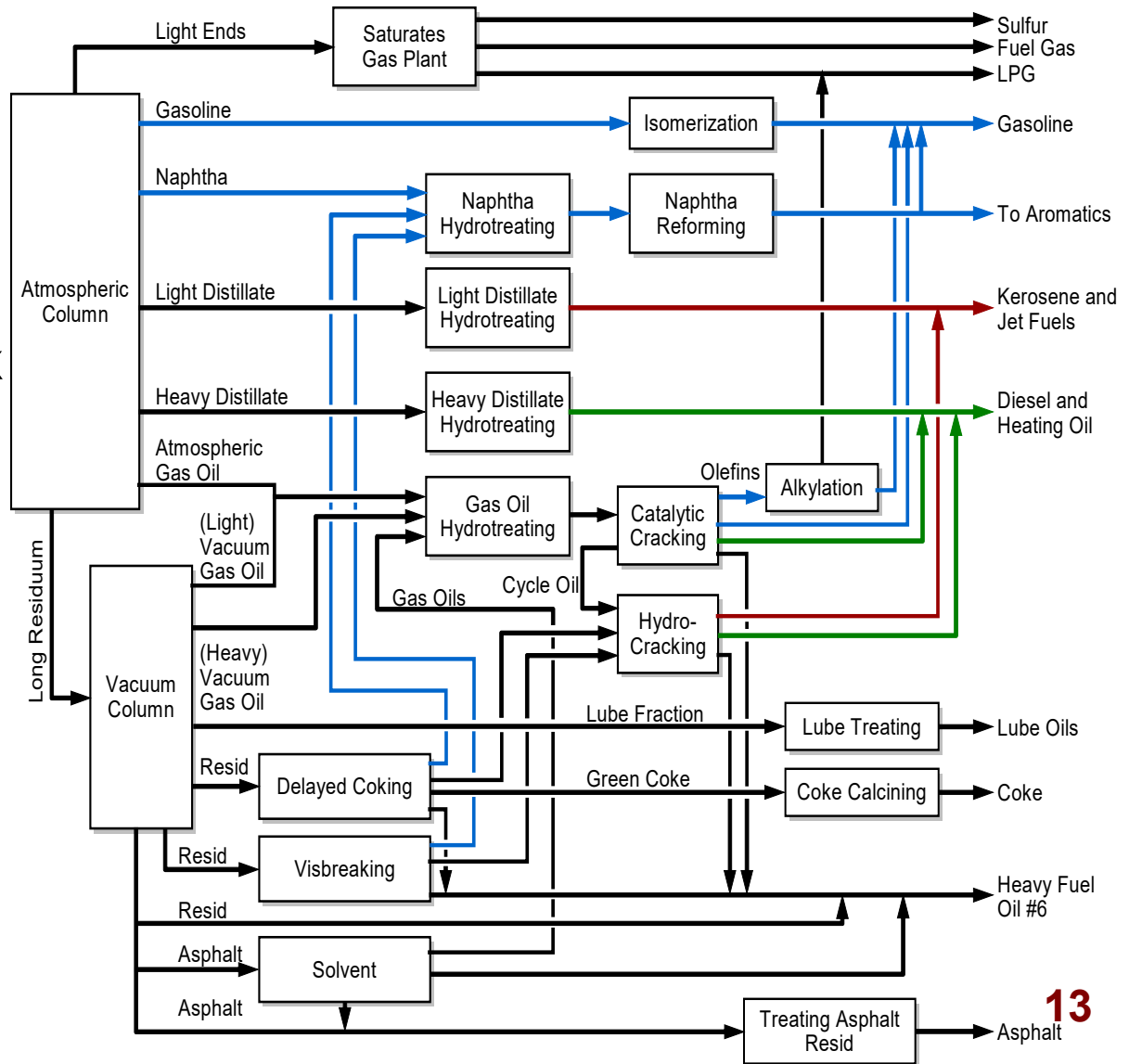

Large-Scale Conversion of Cellulosic Biomass to Hydrocarbon Fuels

- Total conversion of biomass to hydrocarbon fuels requires huge inputs of heat and hydrogen
 - Biomass: $\text{CH}_{1.44} \text{O}_{0.66}$
 - Hydrocarbon fuel (gasoline, diesel, jet fuel): CH_2
- Coal liquefaction (Fischer-Tropsch) and many other processes can be used to convert biomass feedstocks into liquid fuels
- Economics requires massive economies of scale—equivalent to 250,000 barrel/day oil refinery
- Current cellulosic biorefinery designs are less than one-tenth this scale—*mostly constrained by logistics (and perhaps reluctance to face the facts of logistics and scale... 😊)*

Major Logistics Challenge for Large-Scale Cellulosic Biofuels Production

- Cellulosic biomass has low density and is not stable/safe if stored outside
- Uneconomic to ship most cellulosic biomass long distances (except for dense, flowable grains such as corn)
- Solution: *densify biomass by processing in local “depots” into stable, storable densified intermediate product for shipment to large scale biorefinery*
- Achieving these economics requires system integration/integrators: this will be a challenge
- ***But not less of a challenge than continuing with the current unworkable logistics model***

Biomass Logistics Challenge Visualized

ABENGOA



Ethanol
PRODUCER MAGAZINE

Biomass stacked up and ready to go at the Abengoa Biorefinery in Hugoton, Kansas

POET | DSM
Advanced Biofuels



NREL

**Another problem, biomass burns very easily:
*So we need to store it under protected conditions***



Fuel & Co-Products

AFEX Pellets

BIOREFINERY

AFEX
Pelletization

DEPOT

Agricultural
Residues

Herbaceous
Energy Crops

AFEX
Pellets

LANDSCAPE

RUMINANTS

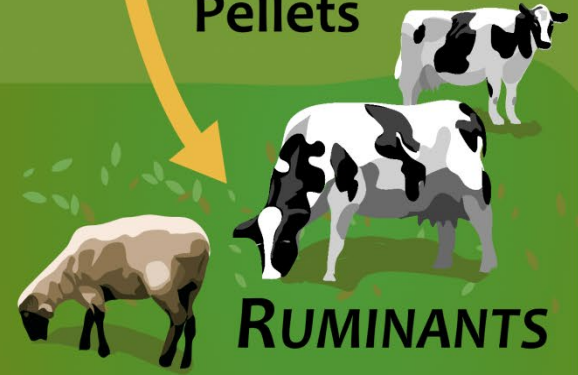
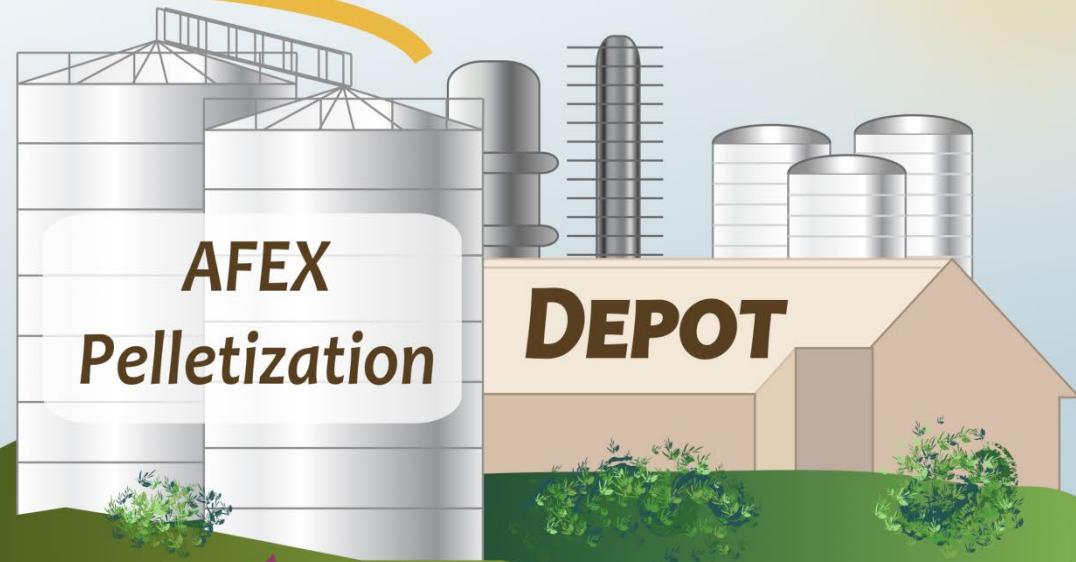
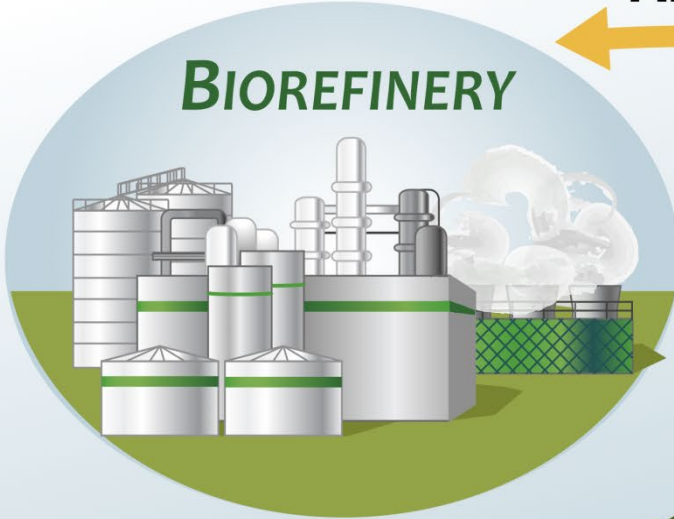

Integrated System Required for Large-Scale Nuclear Biofuels Production

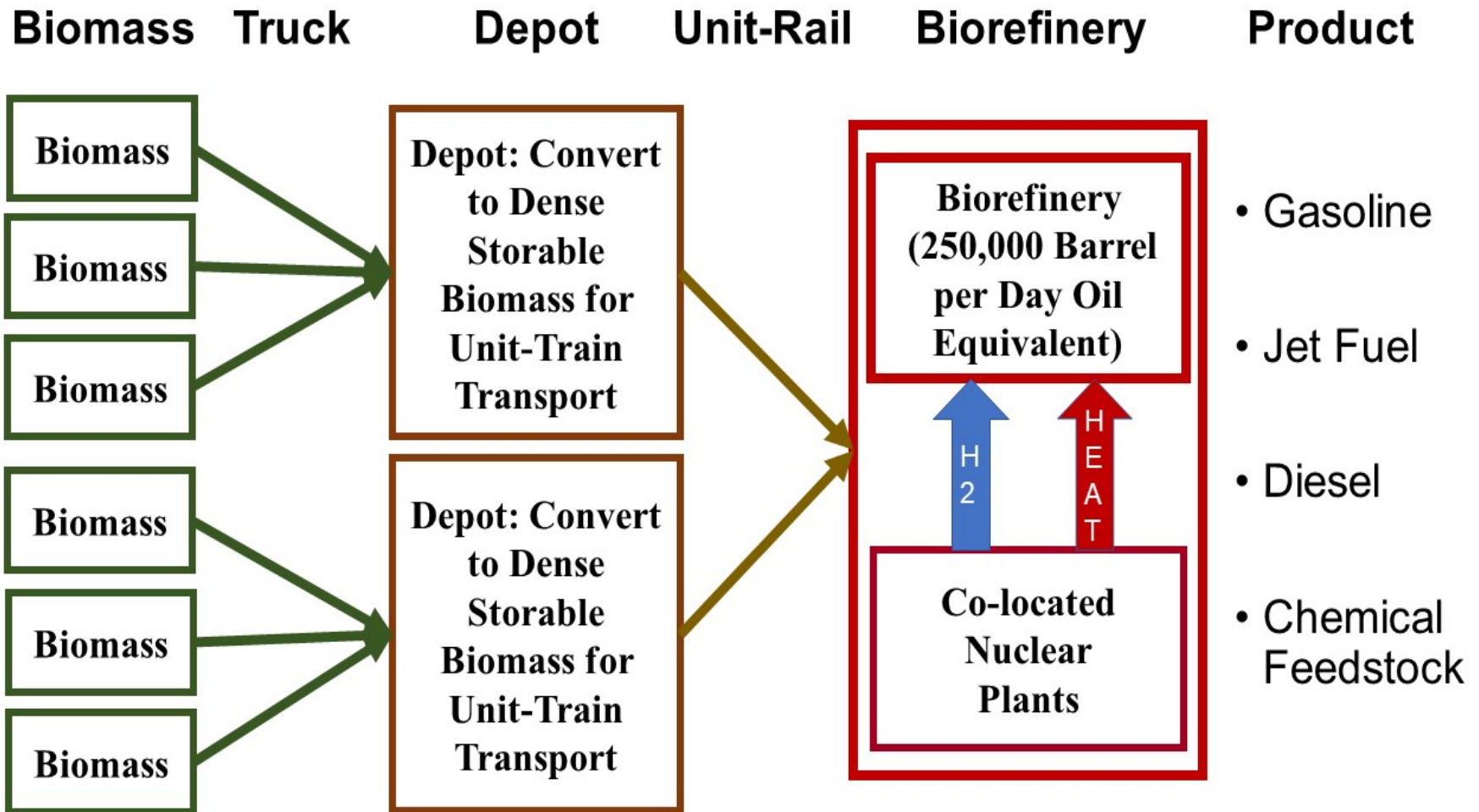

Decoupling Feed Processing from Conversion

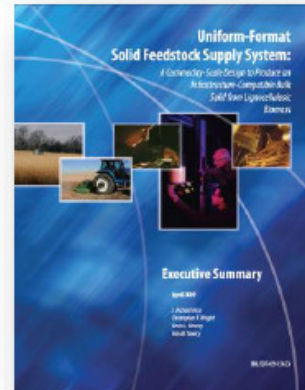
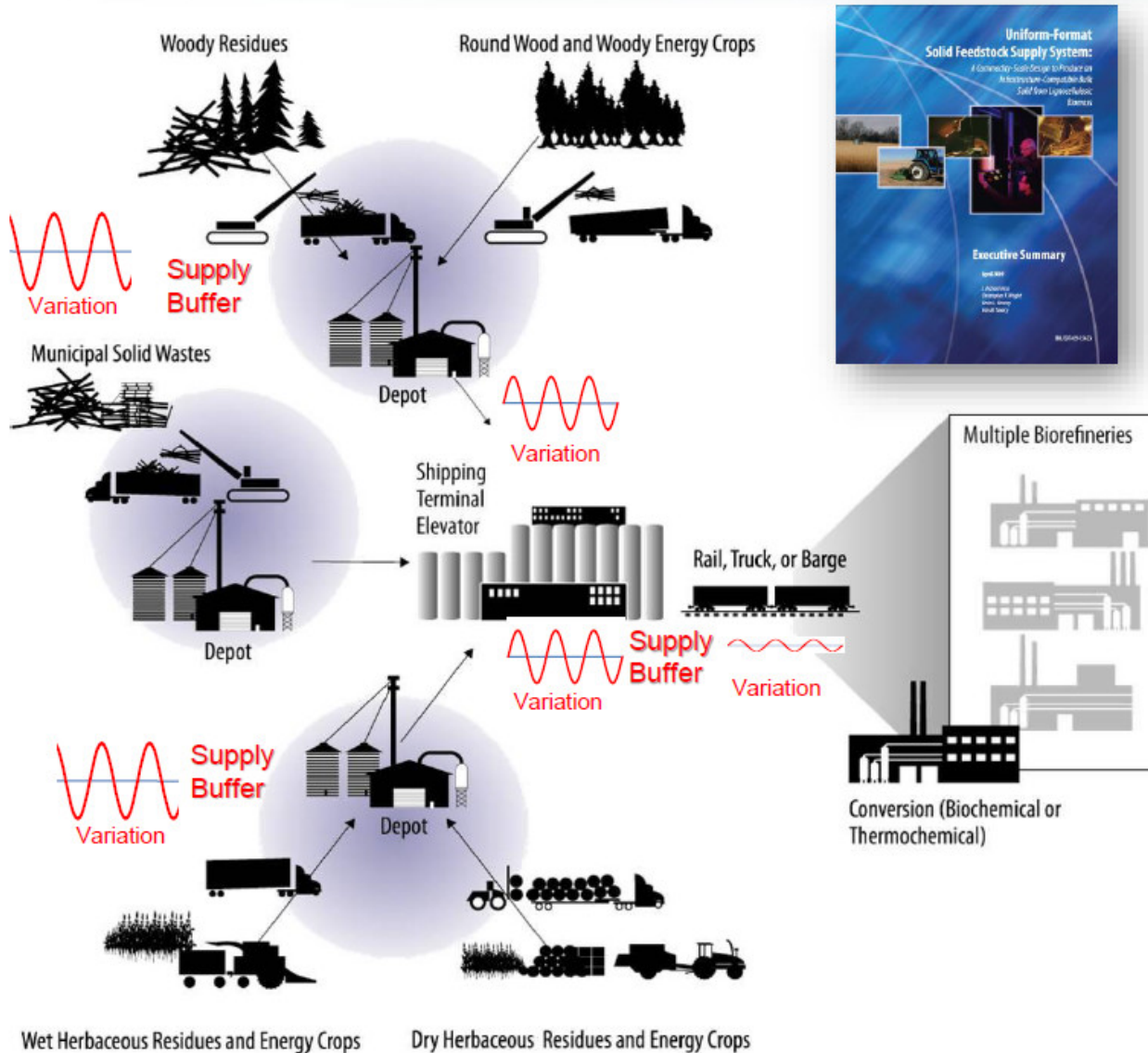

- Wide-spread, interconnected supply network
- Stable, flowable, consistent, and conversion-ready feedstocks
- Reduced feedstock variability in quantity, quality, cost
- Decoupling does not eliminate the feed handling problem, but it does reduce conversion plant downtime.

Future Biofuels Options May Use Massive Quantities of Hydrogen

Comparisons of Options to Produce Hydrocarbon Fuels from Biomass

Platform	Yield, Kg Octane per Kg Cellulose	Input Energy from Hydrogen (%)
Thermochemical	0.310	0
Sugar	0.352	4.9
Carboxylate (Kolbe)	0.422	23.4
Carboxylate (2° Alcohol)	0.469	32.3
Carboxylate (1° Alcohol)	0.528	40.8

Almost Doubles Liquid Fuels per Ton of Biomass and Gives Higher-Quality Fuels with Hydrogen Addition 21

Summer Workshop On Large-Scale Nuclear Biorefineries

- Biorefineries equivalent to 250,000 barrel per day oil refinery
- Gigawatt heat demands and massive hydrogen demand (existing single large oil refinery heat demand measured in gigawatts)
- Reduce land footprint (and associated environmental impacts) by 2x compared to BAU
- Joint Michigan State, MIT, North Carolina State University and Idaho National Laboratory workshop
- **Invitation to workshop participants**

Market C

Paper, Pulp and Liquid Fuels

Coproduction of Paper and Fuels

Paper and Pulp Industry

- Paper mills separate fiber and from other wood components
 - Fiber becomes paper
 - Burn remaining biomass for energy
- Large-scale lower-temperature heat Input
 - Digest wood
 - Dry paper
- **Paper and pulp plant size limited by economic transport distance of pulp wood**

International Paper Company's Kraft pulp and paper mill in Georgetown, South Carolina



4

Paper & Pulp Energy Use (~6% of Global Energy Demand)

- Large total biomass and fossil fuel input (EJ)
- Biomass in large plants produces required electricity
- Nuclear heat can replace biomass & fossil fuel energy input: Chemical pulping uses more heat, Mechanical pulping uses more electricity
- **Can convert biomass that is burnt from heat source to liquid fuels**

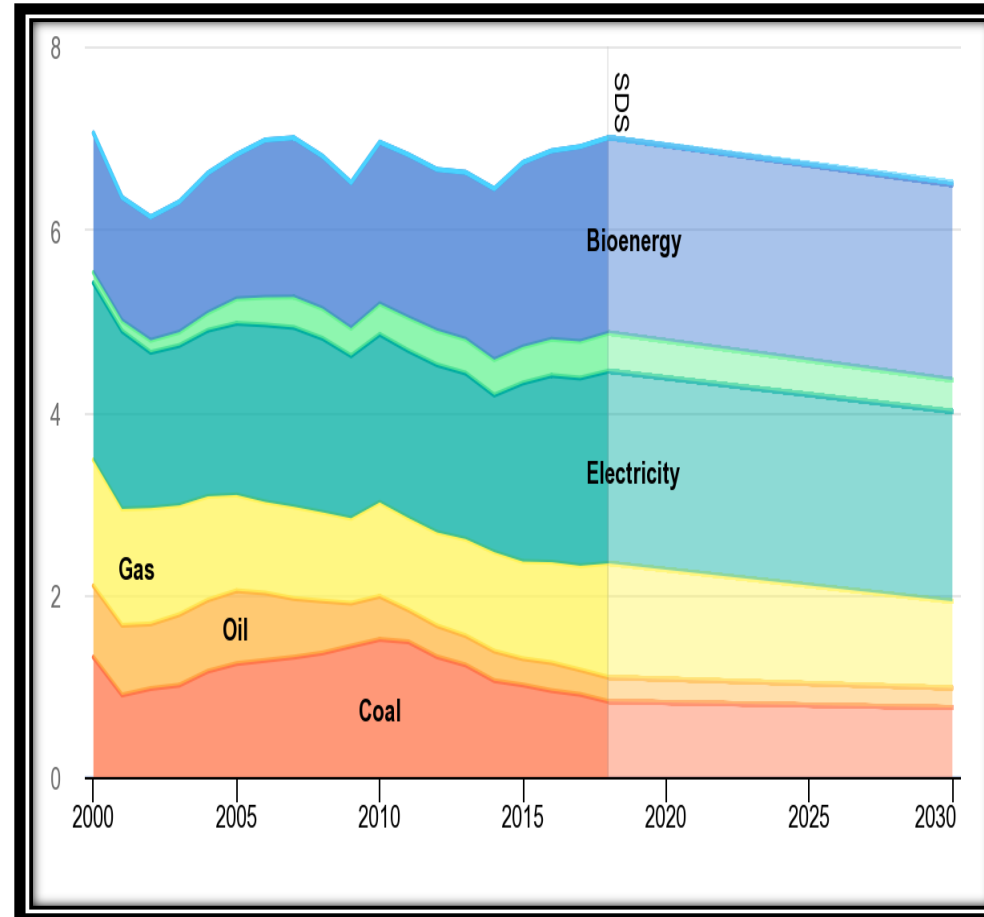

IEA, *Final energy demand in pulp and paper in the Sustainable Development Scenario, 2000-2030*, IEA, Paris <https://www.iea.org/data-and-statistics/charts/final-energy-demand-in-pulp-and-paper-in-the-sustainable-development-scenario-2000-2030>

Conclusions

- Drop-in Biofuels Can Replace Liquid Fossil Fuels
- Quantities and Quality of Liquid Biofuels Depend Upon External Energy Inputs: *Up 10-20% of total U.S. energy demand*
- Two applications:
 - Replace fossil fuel inputs to biofuels, paper and pulp plants
 - Replace burning of biomass for stationary heat supply and convert that biomass into liquid fuels for transport
- Different parts of market require different sizes of nuclear reactor heat inputs
- Most markets are not in urban areas

Questions ??



THE STATUS QUO

INHERENTLY UNSUSTAINABLE

Production of Non-Conventional Petroleum with Loss of and Harm to Natural Ecosystems

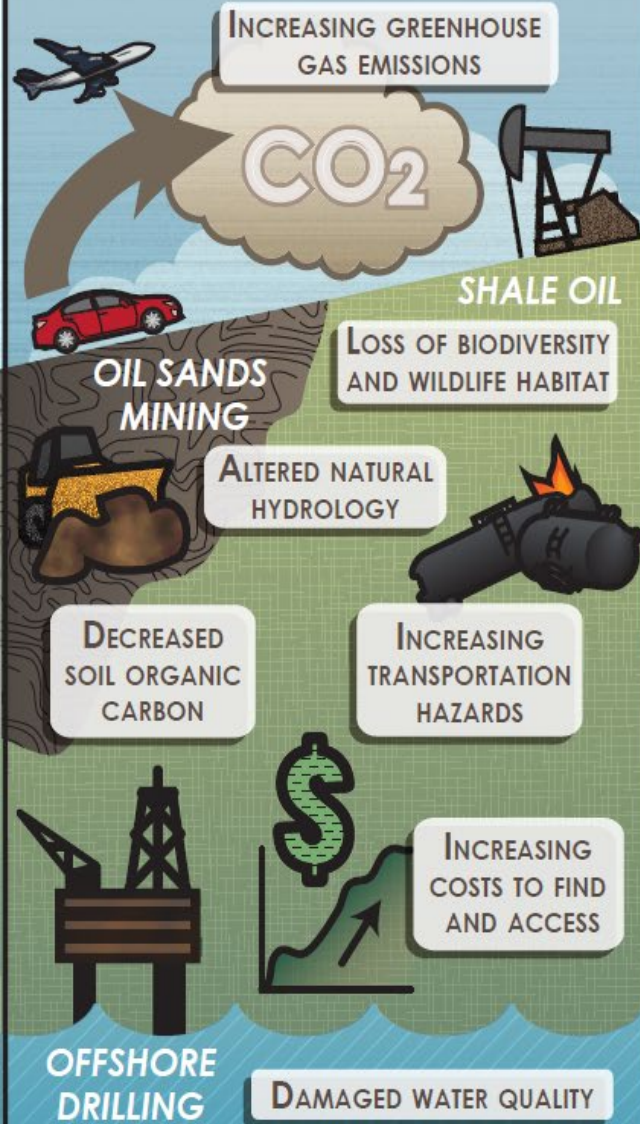

BIOFUELS

POORLY MANAGED

Use of Unsustainable Land Management Practices and/or Conversion of Perennial Ecosystems to Intensive Agriculture

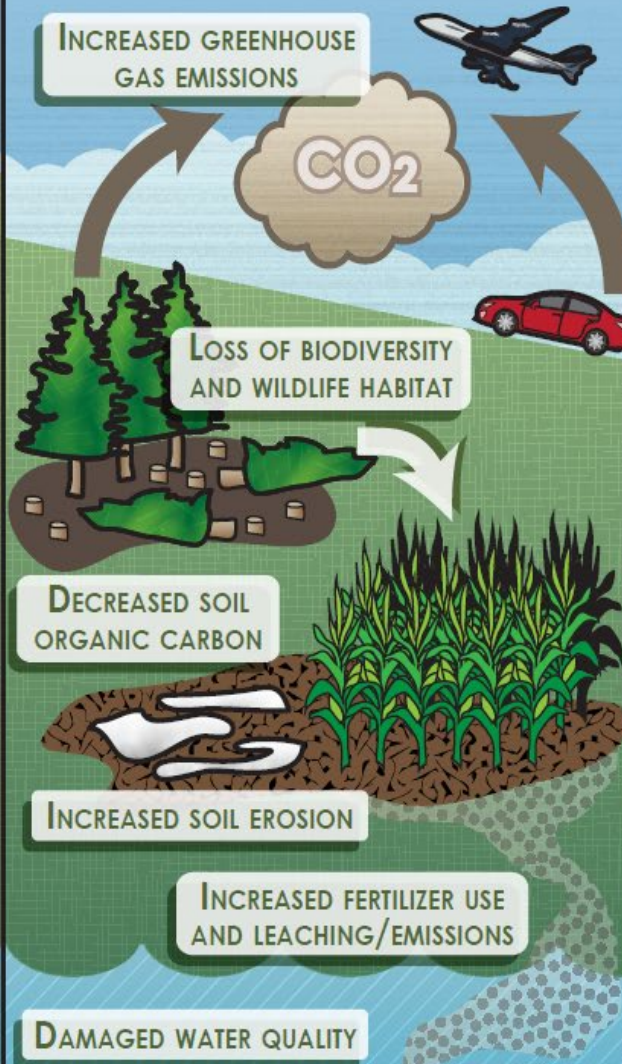

SUSTAINABLY MANAGED

Development of Biofuels Based on Sustainable Land Management Practices and Perennial Feedstocks

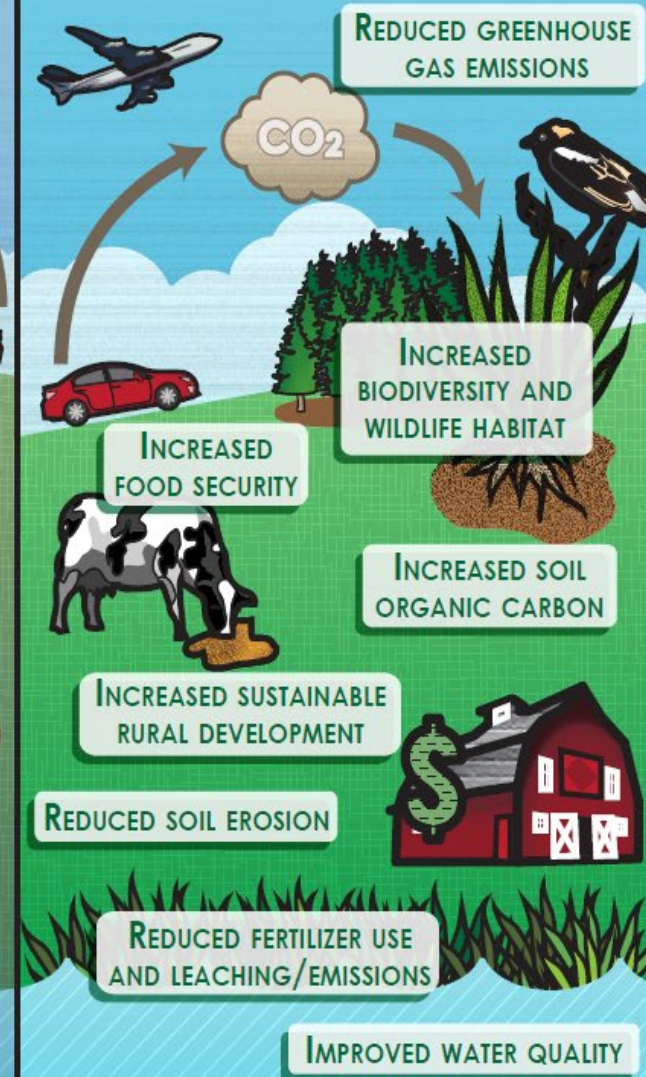



“The Stone Age did not end for lack of stone, and the Oil Age will end long before the world runs out of oil.”

**Sheikh Zaki Yamani
Former Saudi
Arabia Oil Minister**



Grassoline in your tank

Added Information

THE AFEX PROCESS

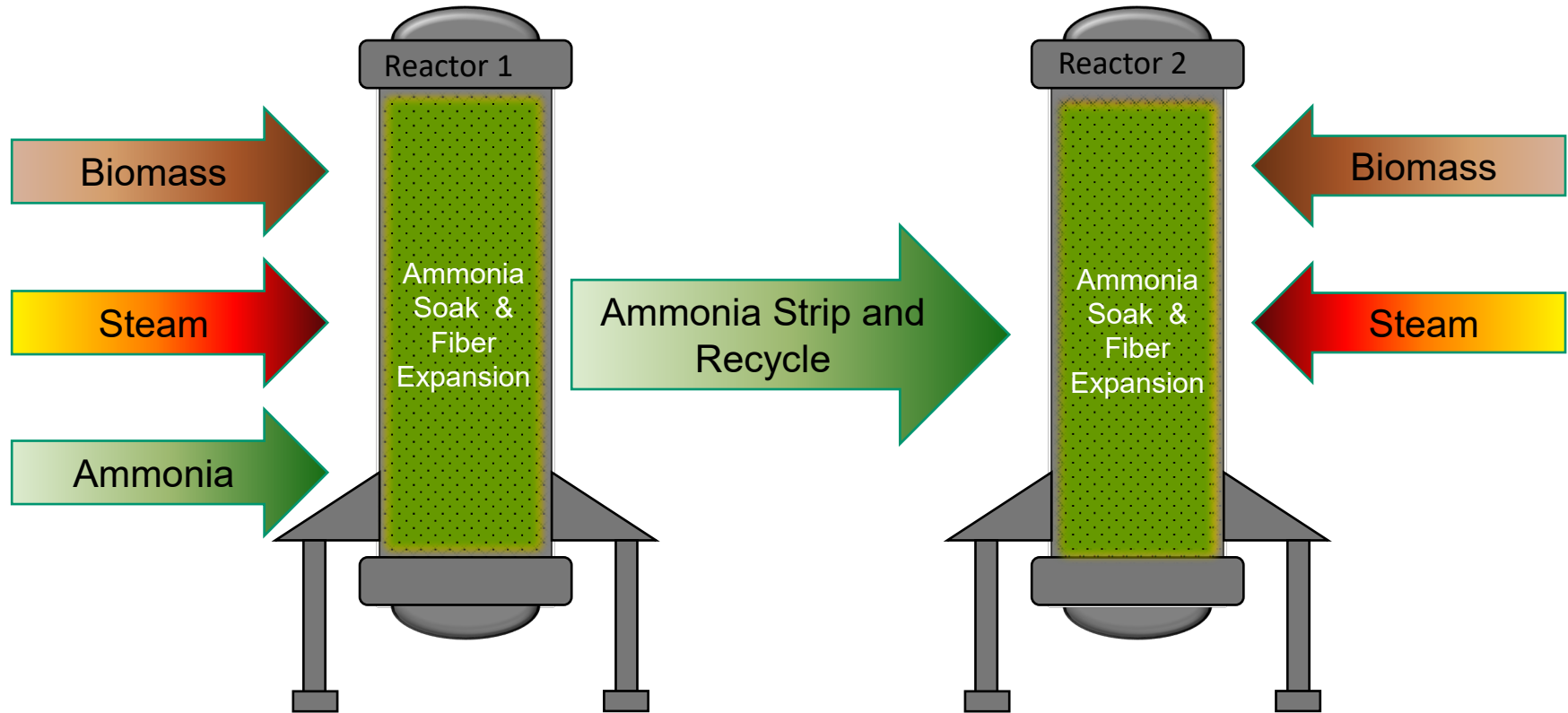

After AFEX treatment:



Treated biomass

Drying

Pelletizing



AFEX pellets

Nuclear Biorefinery System

- Depots consolidate and densify local biomass for economic storeable long-distance transport of biomass
- Unit-train shipment to large-scale biorefineries to enable:
 - Economics of scale
 - Full slate of products
- Nuclear reactors to provide heat and hydrogen to refinery
 - Biomass as renewable carbon source
 - More than double liquid drop-in hydrocarbon biofuels per unit of biomass
 - Enables processing of renewable carbon sources (sewage sludge, etc.) with high carbon content but low energy content
- Replace all fossil-fuel liquid hydrocarbon fuels and chemical feedstocks

