

Technology Innovation for Fission Batteries: Advanced Manufacturing

February 24, 2021

11:00	Fission Battery Initiative and Workshop Overview	Vivek Agarwal (INL)
11:15	Qualification Challenges for Additively Manufactured High Temperature Nuclear Components	Michael McMurtrey (INL)
11:40	Industrialization of Metal AM: Progress and Future Vision	Ed Herderick (The Ohio State)
12:05	Advanced Materials for Microreactors	Derick Botha (NuScale Power)
12:30	Break	
12:45	Design for “_____”.	Slade Gardner (Big Metal Additive)
1:10	A Paradigm Shift in Manufacturing as Opportunity for Fission Battery Success	Isabella J. van Rooyen (INL)
1:35	Perspectives on Materials Degradation Challenges for Fission Battery Deployment	Samuel Briggs (Oregon State University)
2:00	Panel Session	

February 10, 2021

Vivek Agarwal, Ph.D.

Director of the Reactor Systems Design and Analysis Division

Fission Battery Initiative

Nuclear Science and Technology

Fission Battery Initiative

Vision: Developing technologies that enable nuclear reactor systems to function as batteries.

Outcome: Deliver on research and development needed to provide technologies that achieve key fission battery attributes and expand applications of nuclear reactors systems beyond concepts that are currently under development.

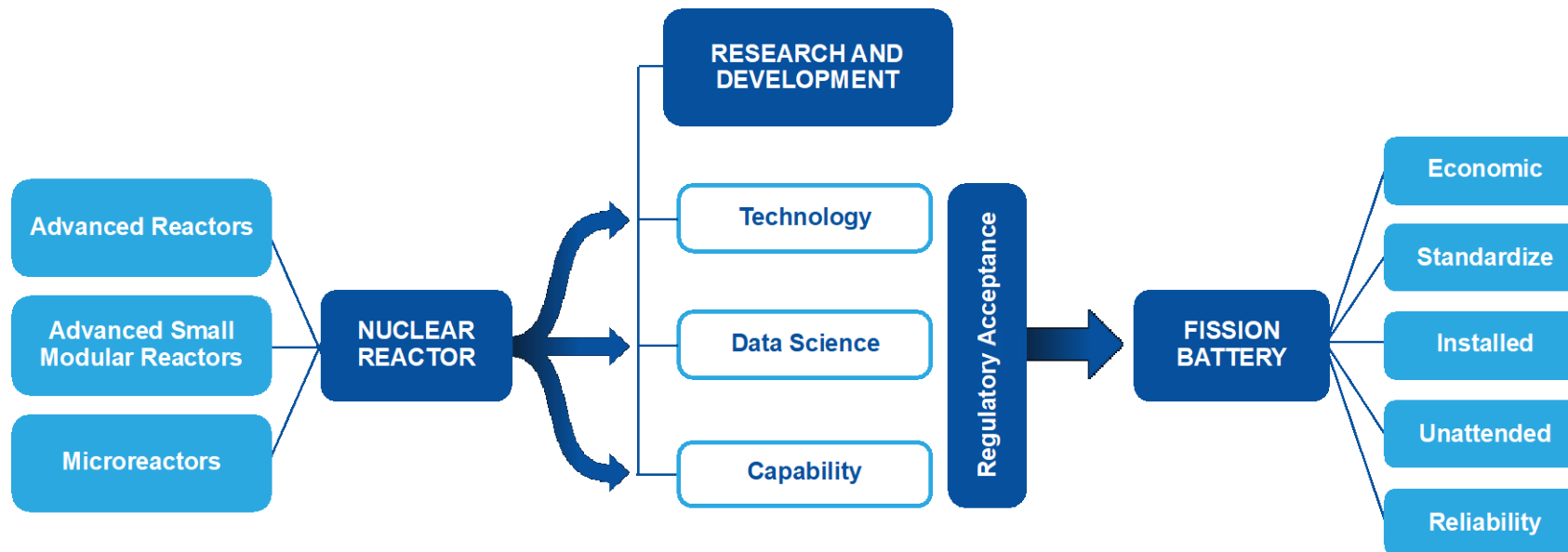

Research and development to enable nuclear reactor technologies to achieve fission battery attributes

Fission Battery Attributes

- **Economic** – Cost competitive with other distributed energy sources (electricity and heat) used for a particular application in a particular domain. This will enable flexible deployment across many applications, integration with other energy sources, and use as distributed energy resources.
- **Standardized** – Developed in standardized sizes, power outputs, and manufacturing processes that enable universal use and factory production, thereby enabling low-cost and reliable systems with faster qualification and lower uncertainty for deployment.
- **Installed** – Readily and easily installed for application-specific use and removal after use. After use, fission batteries can be recycled by recharging with fresh fuel or responsibly dispositioned.
- **Unattended** – Operated securely and safely in an unattended manner to provide demand-driven power.
- **Reliable** – Equipped with systems and technologies that have a high level of reliability to support the mission life and enable deployment for all required applications. They must be robust, resilient, fault tolerant, and durable to achieve fail-safe operation.

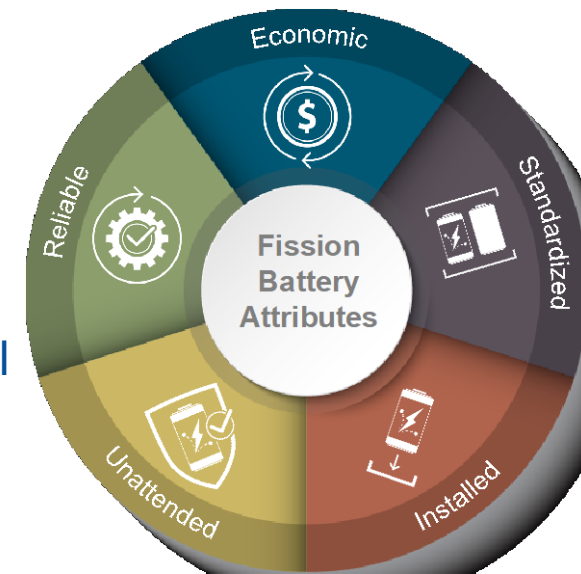

Fission Battery Workshop Series

- **Jointly INL and National University Consortium are organizing workshops across five areas:**
 - Market and Economic Requirements for Fission Batteries and Other Nuclear Systems
 - Technology Innovation for Fission Batteries
 - Transportation and Siting for Fission Batteries
 - Security Scoping for Fission Batteries
 - Safety and Licensing of Fission Batteries
- **Expected outcomes:**
 - Each workshop outcomes are expected to outline the goals of each fission battery attribute



February 24th, 2021

Michael McMurtrey

Materials Scientist, INL

Qualification Challenges for Additively Manufacturing High Temperature Nuclear Components

Additive manufacturing in nuclear

- Additive manufacturing is considered an enabling technology and has the potential to help promote the adoption of future advanced high temperature reactor
 - Increased design flexibility (resulting in increased efficiency)
 - Reduced fabrication costs for complex component geometries
 - Embedded instrumentation/sensors
 - On-site, rapid turnaround replacement parts for operating reactors
- However, not just any material can be used in a nuclear reactor, it must be qualified.

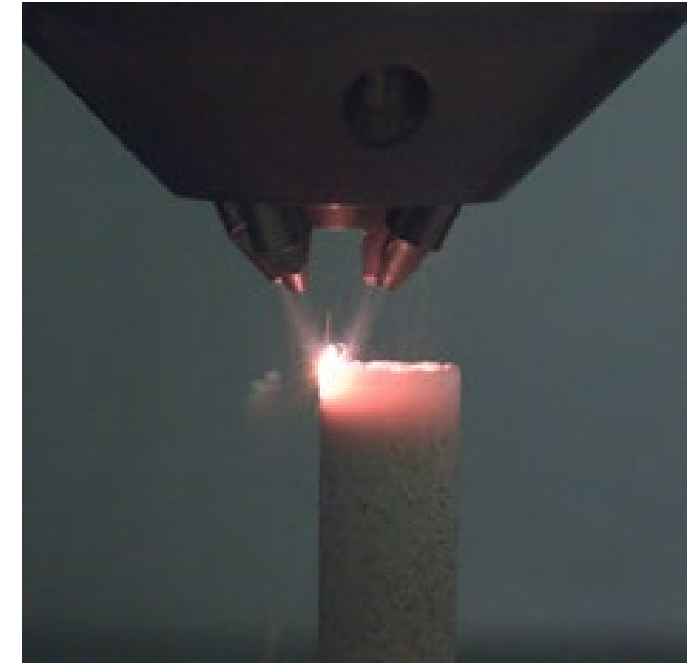
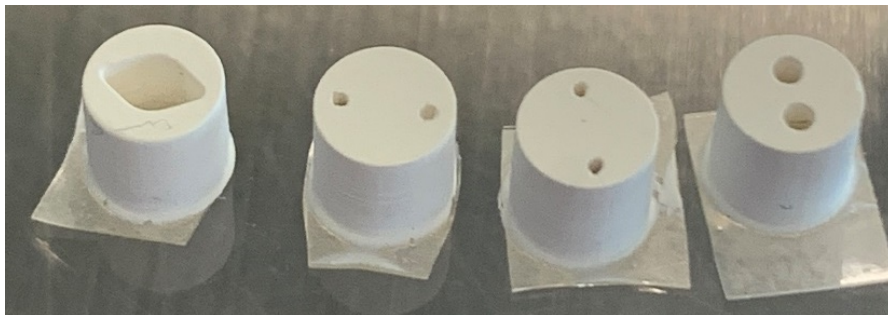

Qualification introduction

- Qualification – Ensure reliable and safe use of materials/components
- Information is needed for qualification
 - How can it fail (failure mechanisms)
 - When will it fail
 - Enough materials data to ensure no failure mechanism occurs unexpectedly (Design models)
- Nuclear components rely heavily on the ASME Boiler and Pressure Vessel Codes

Example design model for Alloy 617

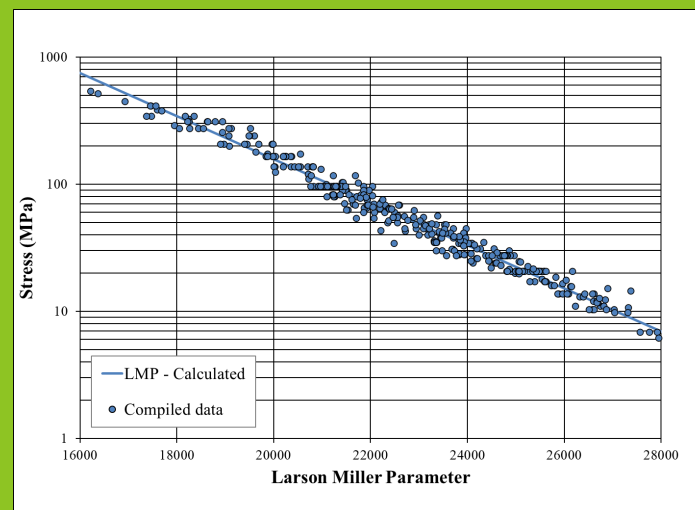
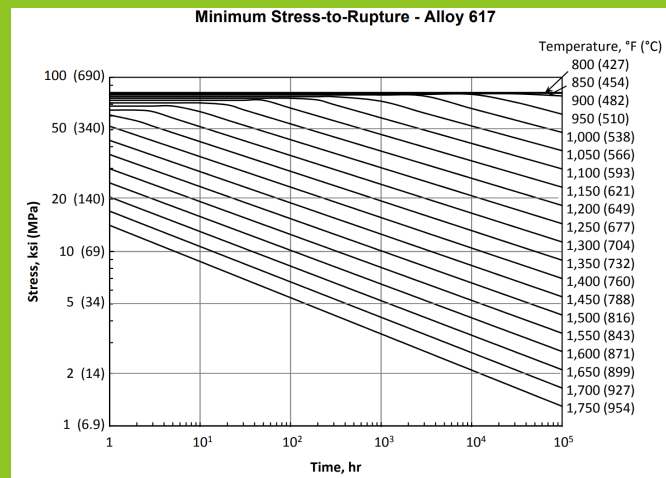

Data from Alloy 617 testing

ASME Section III Division 5 for Nuclear Qualification (Part I)

- Section III Division 1 rules cover light water reactor systems
 - These rules do not allow significant time dependent deformation
 - Upper temperature limit for ferritic materials is 375°C and for austenitic materials is 425°C
- Section III Division 5 “Rules for Construction of Nuclear Facility Components – High Temperature Reactors” has replaced Section III Division 1 for construction of high temperature reactors
- These rules are applicable to high temperature reactor systems, including HTGR, LMR and MSR
 - ASME BPVC does not consider environmental effects for metals
 - For example, Alloy 617 contains up to 15% Co and would not be appropriate in a neutron environment, but the Code would not specifically prohibit it.

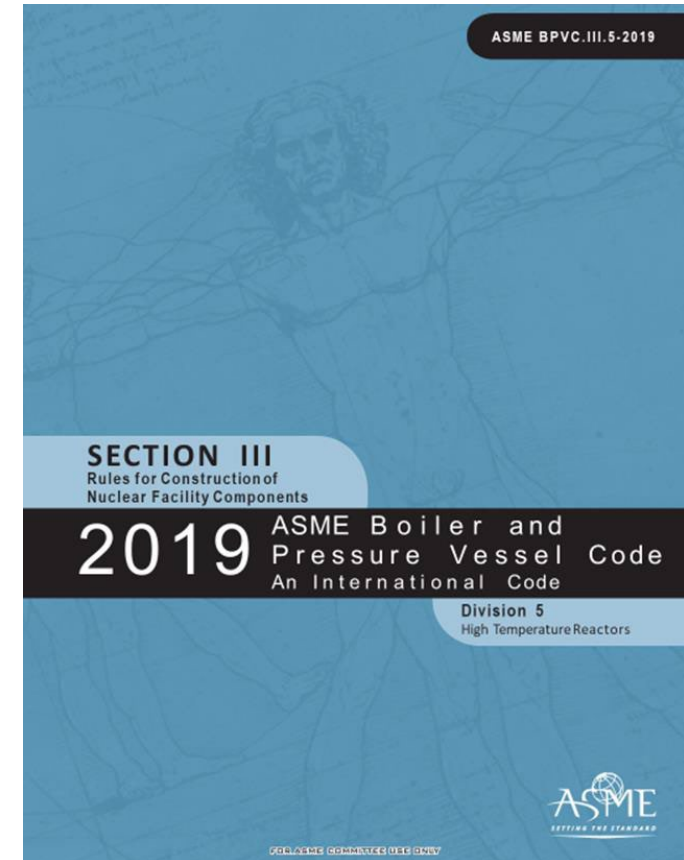

ASME Section III Division 5 for Nuclear Qualification (Part II)

- Only six alloys are allowed for nuclear components under these rules:
 - 2.25Cr-1Mo and V modified 9Cr-1Mo ferritic steels
 - Type 304 and Type 316H stainless steels and Alloy 800H
 - Sixth alloy, Inconel 617, was recently included

Material	Fe	Ni	Cr	Co	Mo	Al	C	Mn	Si	S	Ti	Cu	B	P	V	N	Nb
304/304H	Bal	8.0-10.5	18.0-20.0	-	-	-	0.04-0.08/0.10	2.0 max	0.75 max	0.03 max	-	-	-	0.045 max	-	0.10 max	-
316/316H	Bal	10.0-14.0	16.0-18.0	-	2.0-3.0	-	0.04-0.08/0.10	2.0 max/ 0.04-0.10	0.75 max	0.03 max	-	-	-	0.045 max	-	0.10 max	-
800H	39.5 min	30.0-35.0	19.0-23.0	-	-	0.15-0.60	0.05-0.10	-	-	-	0.15-0.60	-	-	-	-	-	-
2.25Cr-1Mo	Bal	-	2.0-2.5	-	0.90-1.1	-	0.07-0.15	0.30-0.60	0.50 max	0.025 max	-	-	-	0.025 max	-	-	-
9Cr-1Mo-V	Bal	0.40 max	8.0-9.5	-	0.85-1.05	0.04 max	0.08-0.12	0.30-0.60	0.20-0.50	0.010 max	-	-	-	0.020 max	0.18-0.25	0.30-0.70	0.06-0.10
617	3.0 max	44.5 min	20.0-24.0	10.0-15.0	8.0-10.0	0.8-1.5	0.05-0.15	1.0 max	1.0 max	0.015 max	0.6 max	0.5 max	0.006 max	-	-	-	-

ASME Section III Division 5 for Nuclear Qualification (Part III)

- For each allowed material, limits are set for upper temperature and time, e.g., for Alloy 800H 750°C and 300,000 hours
- In addition to time dependent deformation, design rules accounting for creep-fatigue are incorporated
 - The creep-fatigue interaction model takes into account the deleterious effects of creep and fatigue together
 - If creep and fatigue were solely considered separately, design models would be non-conservative, as creep-fatigue interactions cause failure earlier in life than would be expected

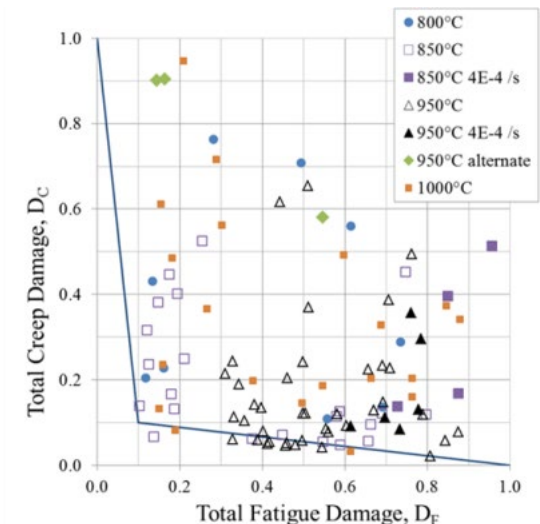
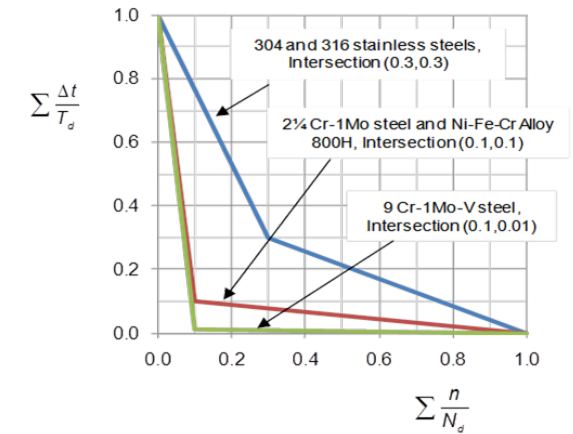

ASME Code Qualification

- Higher temperature design of VHTR systems might require structural alloys with elevated temperature properties exceeding those of the six Code qualified alloys; new materials would need to be qualified
- Section III Division 5, Appendix HBB-Y, “Guidelines for Design Data Needs for New Materials” describes required properties
 - Technical basis established through DOE Advanced Reactor Technology base program on the Alloy 617 Code Case in support of HTGR/VHTR applications

Required testing to introduce a new structural material into Section III, Division 5, or a Division 5 Code Case

- HBB-Y-2100 Requirement For Time-independent Data
- HBB-Y-2110 Data Requirement for Tensile Reduction Factors for Aging
- HBB-Y-2200 Requirement for Time-Dependent Data
- HBB-Y-2300 Data Requirement for Weldments
- HBB-Y-3100 Data Requirement for Isochronous Stress-Strain Curves
- HBB-Y-3200 Data Requirement for Relaxation Strength
- HBB-Y-3300 Data Requirement for Creep-Fatigue
- HBB-Y-3400 Data Requirement for Creep-Fatigue of Weldments
- HBB-Y-3500 Data Requirement for Cyclic Stress-Strain Curves
- HBB-Y-3600 Data Requirement for Inelastic Constitutive Model
- HBB-Y-3700 Data requirement for Huddleston multiaxial failure criterion
- HBB-Y-3800 Data Requirement for Time-Temperature Limits for External Pressure Charts
- HBB-Y-4100 Data Requirement for Cold Forming Limits
- Validation of Elastic-Perfectly Plastic (EPP) Simplified Design Methods for the new alloy

Qualification of AM components

- NEI Advanced Manufacturing Task Force prepared a Roadmap for Regulatory Acceptance of Advanced Manufacturing Methods
 - Laser Powder Bed Fusion
 - PM-HIP
 - Electron Beam Welding
 - Cold Spray
 - Directed Energy Deposition
 - And many others

Roadmap for Regulatory Acceptance of Advanced Manufacturing Methods in the Nuclear Energy Industry

Prepared by the Nuclear Energy Institute
May 13, 2019

Additive manufacturing in the ASME BPVC

- ASME Special Committee on Advanced Manufacturing for Pressure Retaining Components was formed in 2017
 - Is in the process of releasing a report on the “Criteria for Pressure Retaining Metallic Components Using Additive Manufacturing”
 - “...the AM built cycle relies on the results of the tensile test of the witness sample to provide the final measure of component quality”
 - Witness specimens shall be constructed and tested with each production build
 - Witness specimens are material test specimens generated during the production build cycles to measure and ensure on-going process stability
 - Used for room temperature tensile tests and metallographic analysis

“The ASME AM Committee did not investigate data for AM components operating in the material creep regime. Creep data was discussed but sufficient material property data was not available to accept AM components operating at elevated temperature in the scope of the current AM criteria”

Additive manufacturing in the ASME BPVC

- ASME Sec. III Code Case submitted in Aug. 2019 for Laser Powder Bed Fusion of 316L
 - Permit ASTM F3184 (Standard Specification for Additive Manufacturing Stainless Steel Alloy (UNS S31603) with Powder Bed Fusion
 - Requires test specimens (witness specimens) to ensure minimum required tensile properties are met (room temperature tensile tests)
 - Applicable to Section III Division 1

Room Temperature Condition	Tensile Strength, MPa (ksi), X and Y Directions	Tensile Strength, MPa (ksi), Z Direction	Yield Strength at 0.2% Offset, MPa (ksi), X and Y Directions	Yield Strength at 0.2% Offset, MPa (ksi), Z Direction	Elongation in 50 mm (2 in.) or 4D, (%), X and Y Directions	Elongation in 50 mm (2 in.) or 4D, (%), Z Direction	Reduction of Area, %, X and Y Directions	Reduction of Area, %, Z Direction
A - Stress Relieved ^B	515 (75)	515 (75)	205 (30)	205 (30)	30	30	40	40
A - Solution Annealed	515 (75)	515 (75)	205 (30)	205 (30)	30	30	30	30
B	515 (75)	515 (75)	205 (30)	205 (30)	30	30	30	30
C	515 (75)	515 (75)	205 (30)	205 (30)	30	30	30	30
E	no requirement	no requirement	no requirement	no requirement	no requirement	no requirement	no requirement	no requirement

^A A gauge length corresponding to ISO 6892 may be used when agreed upon by the component supplier and purchaser.

^B Mechanical properties conform to Specification [A479/A479M](#).

AM qualification for high temperature use

- There is an ASME Task Group examining AM for Division 5 applications (formed February 2020)

Charter

Fabrication of nuclear components for elevated temperature service using advanced manufacturing (AM) methods is of increasing interest from the vendor community. These methods can include, for example, hot isostatic pressing near net shape components from powder, powder bed fabrication, wire feed methods and diffusion bonding. This Task Group will determine appropriate approaches for qualifying materials processed by AM methods and specifying acceptance criteria for components produced by these methods. The goal of the Task Group is to develop Code Actions for incorporating AM materials and components in Division 5 for elevated temperature nuclear construction.

A path forward for qualification is still not clear

Challenges facing AM in high temperature nuclear applications

- Little data on elevated temperature testing of AM material
 - Typical existing data does not fully capture all properties of interest
 - Often short timeframes (100 hour creep tests)
- Can witness specimens still be used
 - Room temperature tensile does not adequately describe creep, fatigue or other elevated temperature characteristics of interest
 - Elevated temperature testing is more difficult, expensive and time consuming
 - In a typical qualification, creep data can only be extrapolated by a factor between 3 to 5

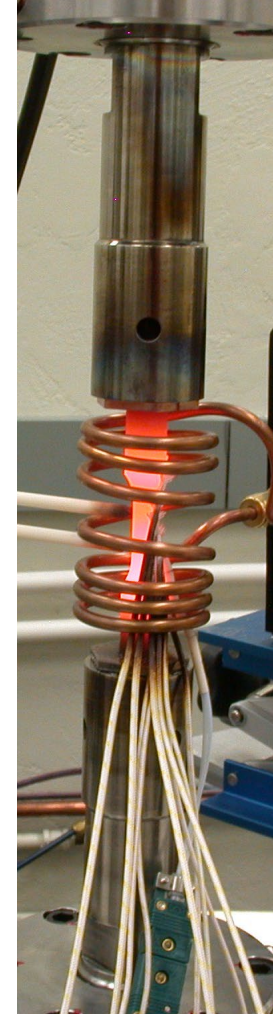

Challenges facing AM in high temperature nuclear applications

- High diversity between manufacturing techniques
 - New qualification plan needed for each technique?
 - New qualification plan needed for each material within each technique?
 - This is a rapidly changing landscape (both techniques and desired materials)

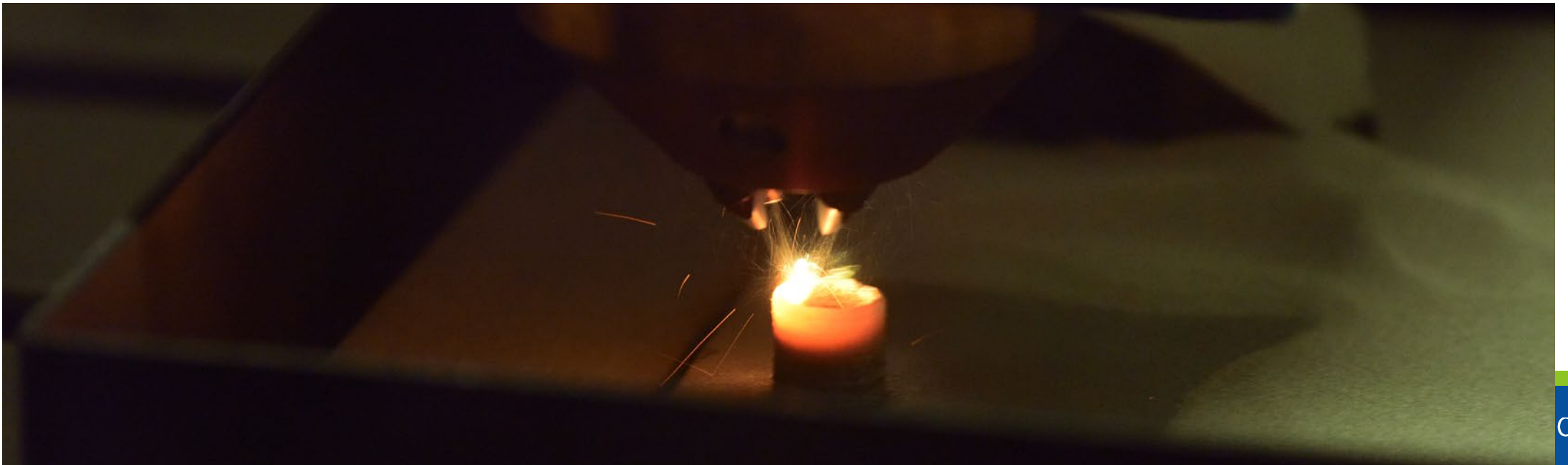

Modeling/Simulation Challenges

- Could supplement direct property tests and microstructural characterization
- Challenges must be overcome before widespread acceptance
 - Higher degree of variability in AM vs. wrought materials, which expands needed characterization and the space of initial conditions a model must accurately represent
 - AM materials often exhibit weld-like morphologies, there is less experience modeling these type of complex microstructures
 - There are fewer high-quality reference datasets available for AM techniques, no available long-term data
 - Must convince regulators, as well as codes and standards bodies, to accept modeling and simulation in the qualification process

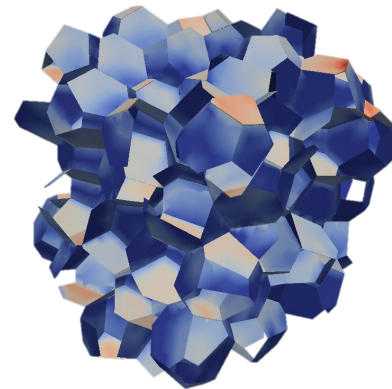
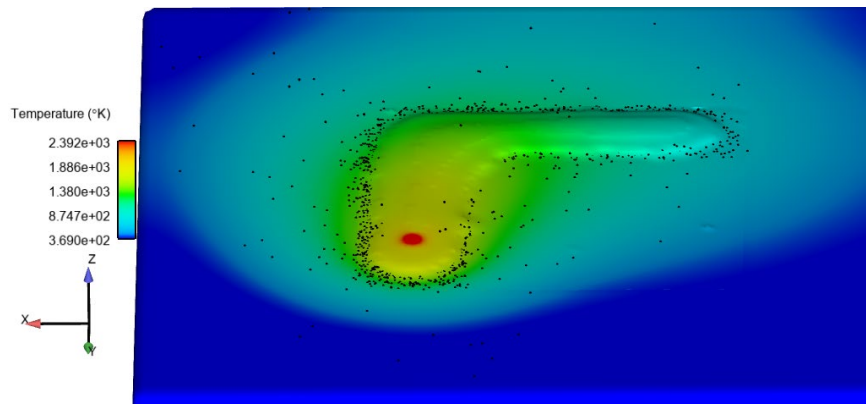

Path forward

- No set path forward at this point, but it potentially could include
 - Revised qualification methods that incorporate modeling/simulation
 - High-throughput testing/characterization to make specimen testing more feasible
 - Feedback monitoring and control during AM build processes
 - Completely new qualification methods that don't rely on witness specimens for validation

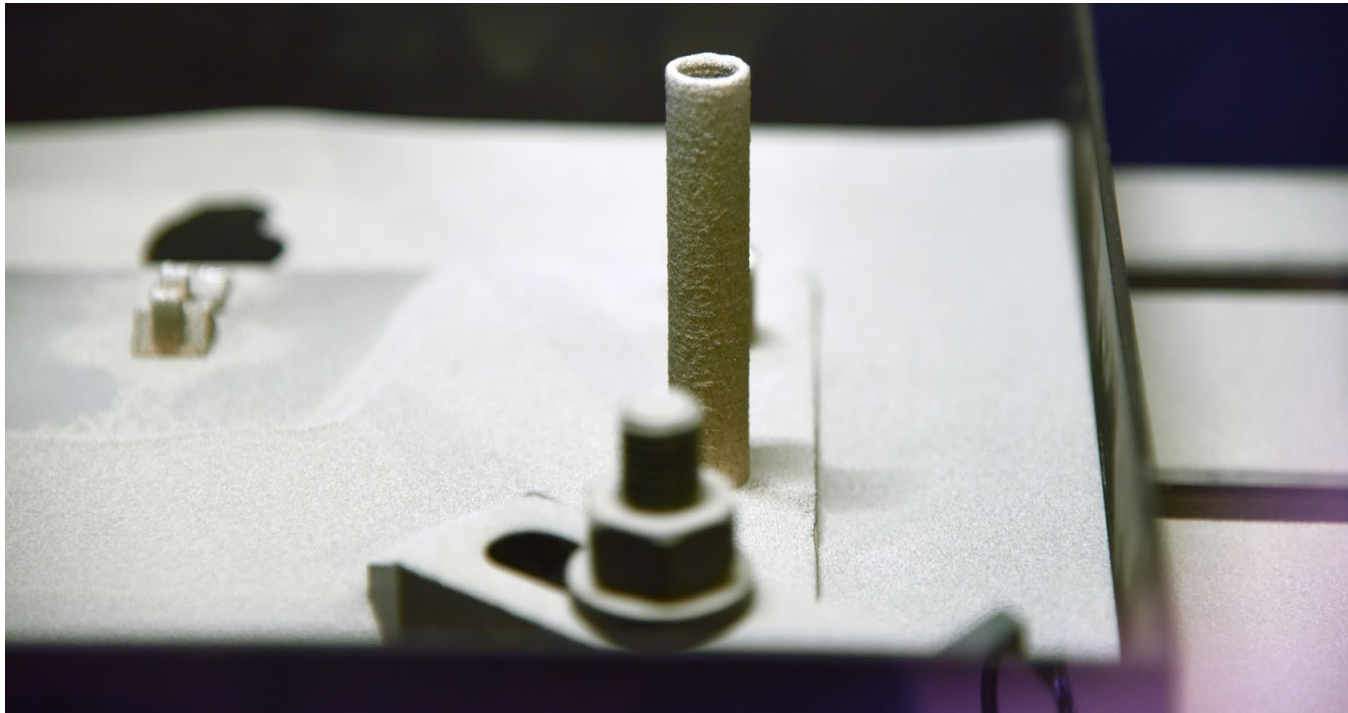

The Center for Design and Manufacturing Excellence

University Research, Industry Implementation for Manufacturers and Entrepreneurs

Metal Additive Manufacturing: Progress and Opportunities

Edward D. Herderick, PhD
Director of Additive Manufacturing
Joint Appointment at INL



THE OHIO STATE
UNIVERSITY

Open Questions for Fission Battery Fabrication

- How to integrate sensors and structural health monitoring?
- How to ensure autonomous and continuous operation?
- What is the role for AI / Machine Learning?
- How can new processes like AM empower brand new design philosophy?
- How will advanced inspection support risk reduction?



How to integrate ***Design*** with materials and ***Manufacturing***? New materials and processes offer revolutionary opportunities for new designs but need to develop the approach together.

Foundation is risk-based qualification and certification methodology that ***enhances*** safety and performance by enabling new materials and processes





The Center for Design and Manufacturing Excellence (CDME) is the industrial manufacturing research center at OSU and is part of the College of Engineering

Established in 2015, The Center includes 22 staff, 45 undergraduate student researchers as well as numerous faculty across OSU College of Engineering, College of Arts and Sciences, College of Medicine, and College of Business

Additive Manufacturing activity began in 2017:

CDME has comprehensive capability including 5 metal printing modalities at industrial scale

Other signature labs include AI enabled manufacturing and Biomedical Engineering Devices



Vision: Additive Manufacturing is a transformational technology that will revolutionize the way products are designed and made.

Mission: Grow Additive Manufacturing activities across OSU with our students, faculty, staff, and ecosystem partners.



CDME is innovating across the entire Additive value stream in multiple modalities:



EB-PBF



L-PBF

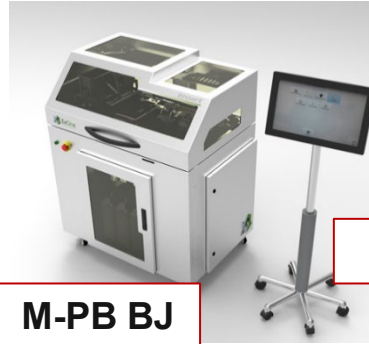

M-PB BJ



L-PBF



**Arc-DED
Wire**



**L-DED
Powder**



L-PBF



L-PBF



Polymer Extrusion



FDM

Metal AM (particularly BIG metal AM) has Exploded Over the Past 10 years!

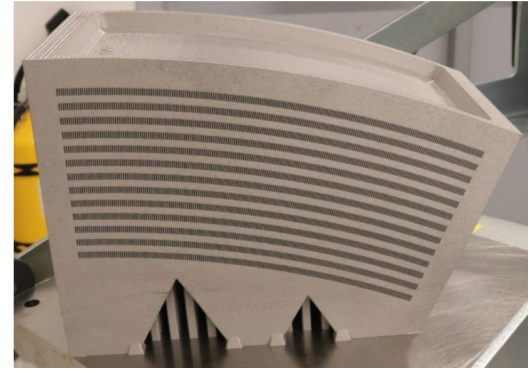

Source: GE

Source: UTC/Raytheon



Source: Westinghouse

Source: Siemens

Source:
Lincoln Electric

GE Catalyst Engine
Replaced Investment
Castings and fasteners with
AM metal parts
In total replaced 855 parts
with 12

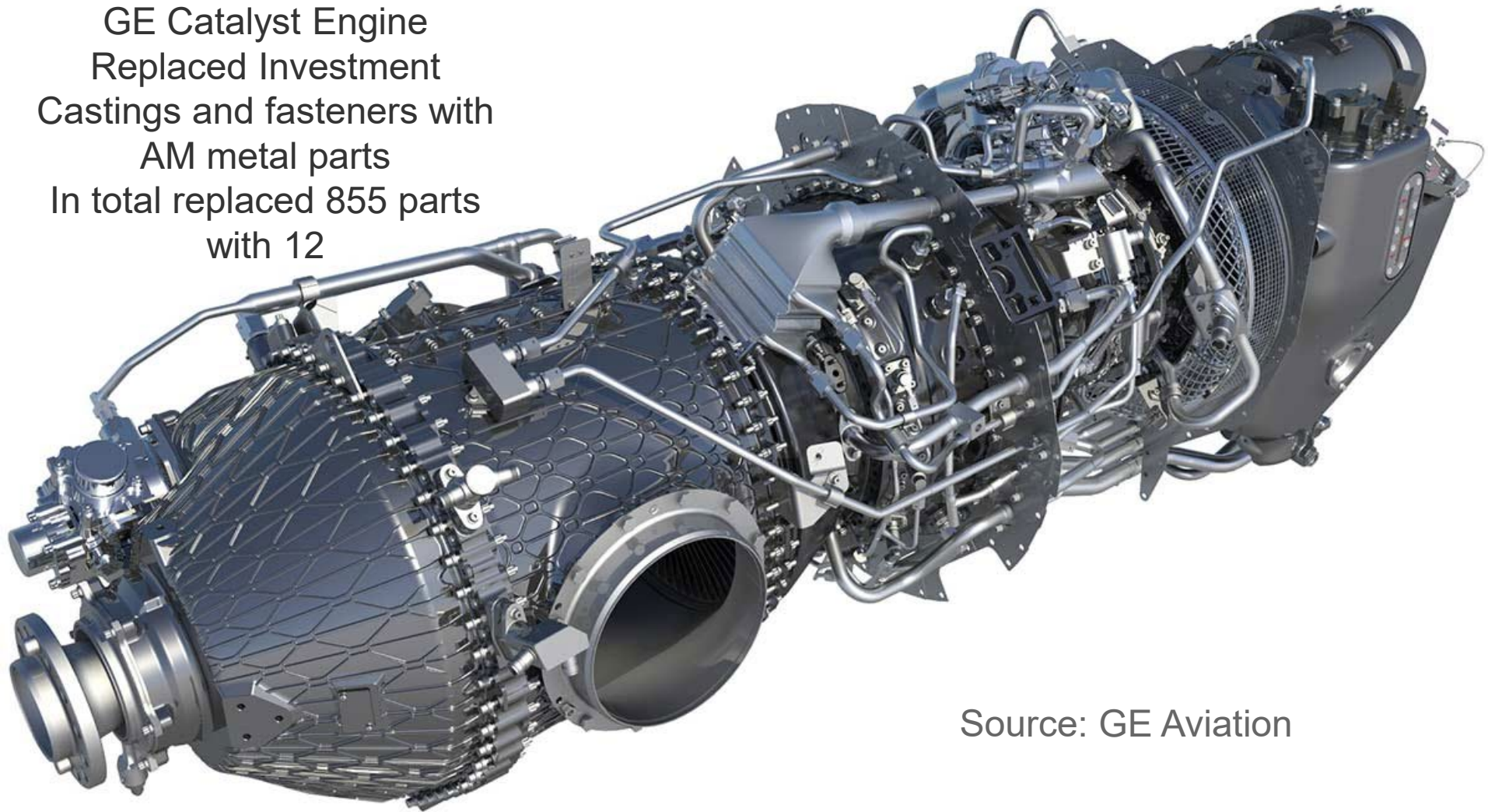

Source: GE Aviation



“Smart” PBF-L Build Plate

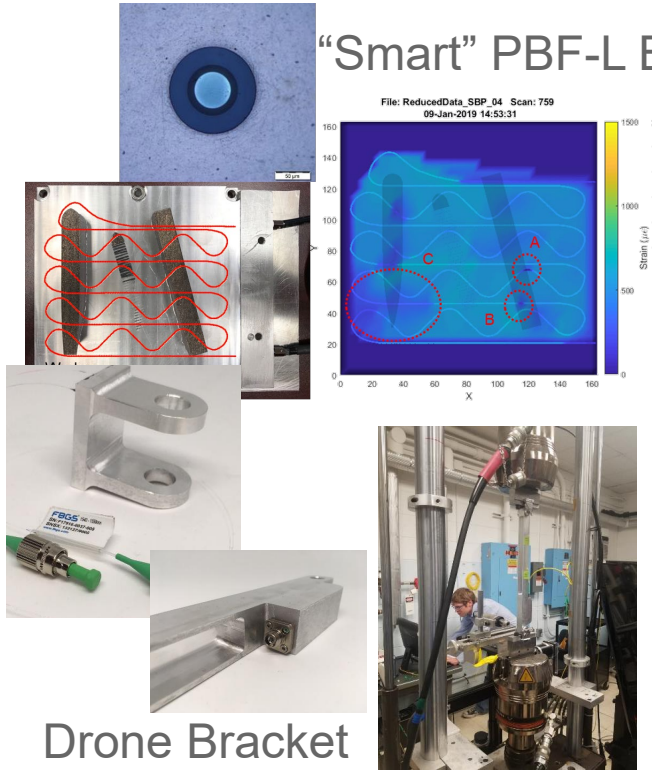

Temperature Monitoring using Embedded Thermocouples

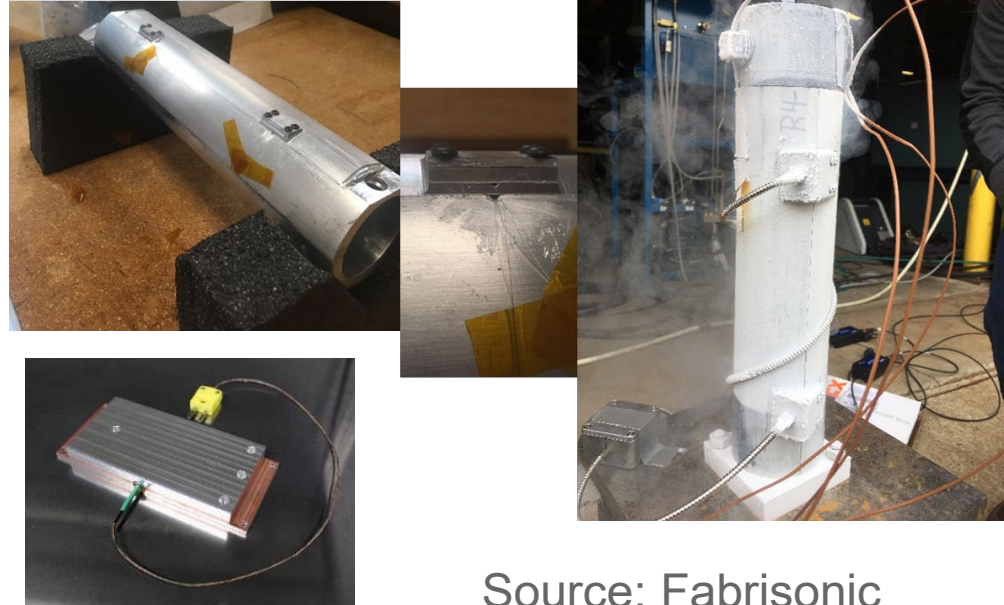

Source: Fabrisonic

Strain sensing using embedded fiber optic cables

Some Trends Driving Industrial AM R&D

- Metal AM has proven its Mettle
- A big driver is need for larger, more complex parts
- That informs our AM industrialization research themes at OSU CDME:
 - Design and topology optimization
 - Materials characterization and development
 - Multi-materials component development
 - Process scale-up for industrialization

PBF-L Inspection and Qualification

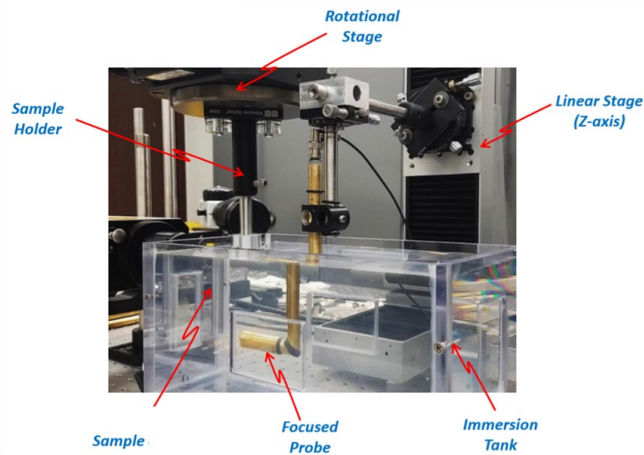
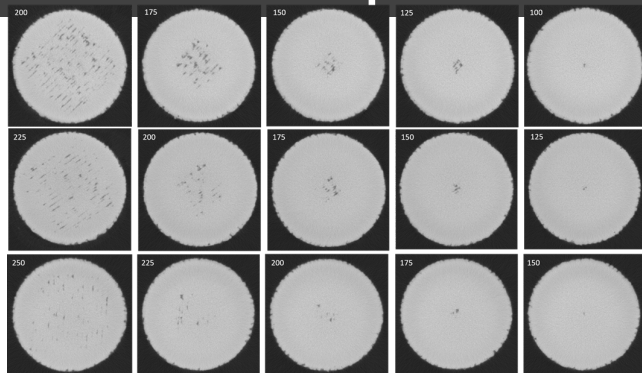

Collaboration with KBR using advanced PA-UT for metal AM NDE

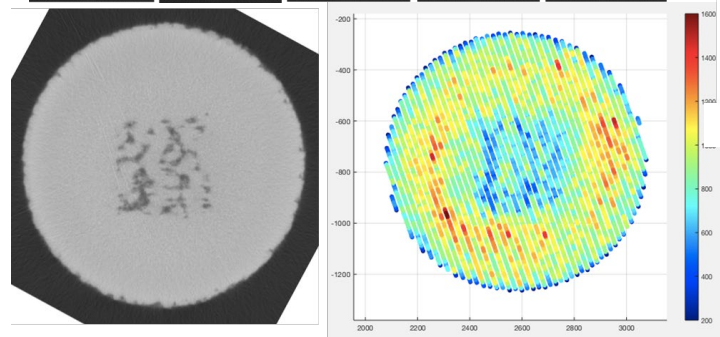

OSU has ongoing programs evaluating effects of defects, and correlating measurements from in-process meltpool monitoring to X-Ray CT

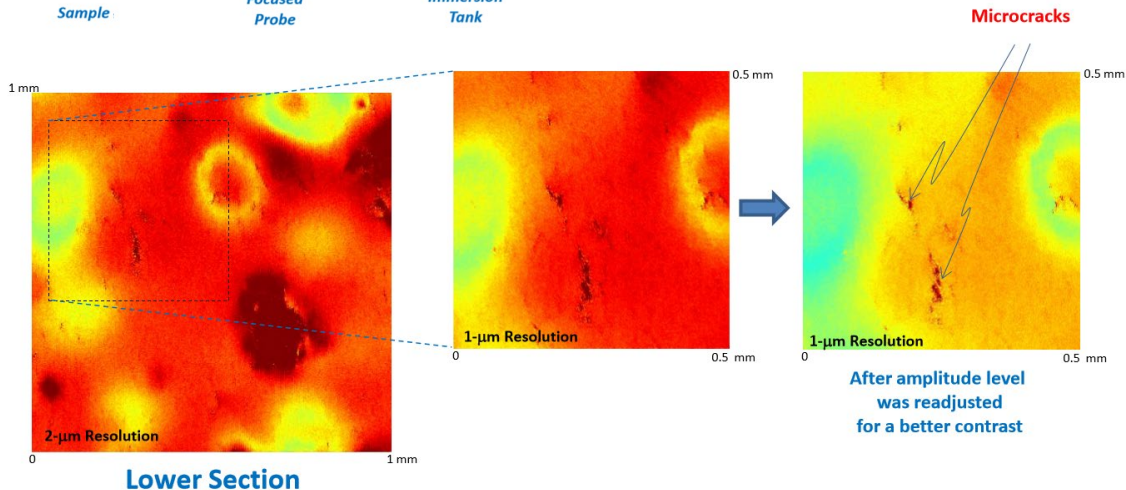

Multi-Laser Powder Bed Fusion

- Strong driver to speed up metal printing to reduce capital cost
- Multiple projects evaluating defects and microstructure of stitching region of metal multiple laser powder bed fusion
- Further extension on developing standards for PBF-L printing with multiple lasers
- EBSD colorized images showing grain structure of Nickel Alloy 718 stitching region of sample built using two laser PBF-L

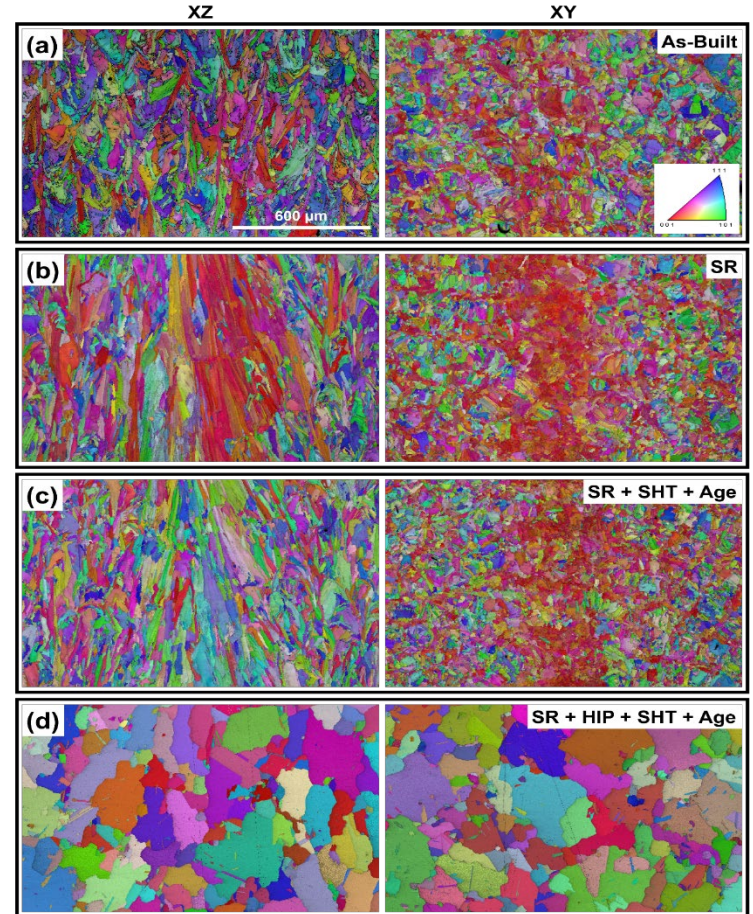



Additive Solutions



How can we use topology optimization for a large structure? We chose a TKY joint

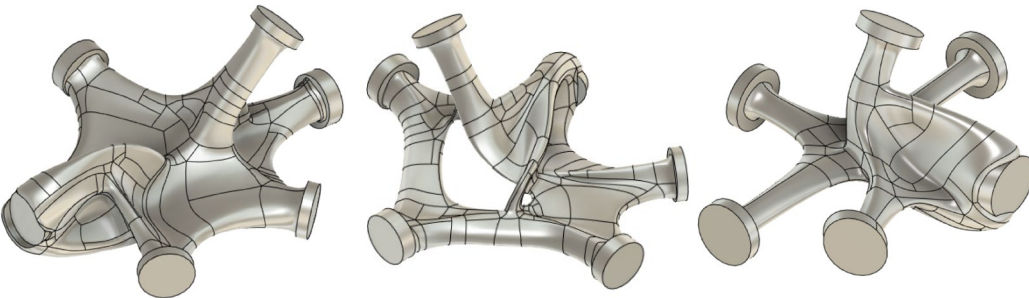

Source: Cedar Point



Additive Solutions

How can we use topology optimization for a large offshore structure? We chose a TKY joint



Some Closing Thoughts:

- Additive Manufacturing has captured the imagination of the product development community and is now a foundational technology like CAD, CNC, Digital
- AM technologies have a strong role to play by enabling revolutionary Fission Battery designs
- Perception today doesn't match industrial reality of deployment --- how to demonstrate new approaches that reduce risk?



NUSCALE™
Power for all humankind

Advanced Materials for Microreactors

Wednesday February 24, 2021

Derick Botha
Innovation Manager



Topics Covered

- NuScale Microreactor Applications
- Active Collaborations
- Qualification of Advanced Materials
- Opportunity to Collaborate on Materials Qualification



NuScale Microreactor Applications

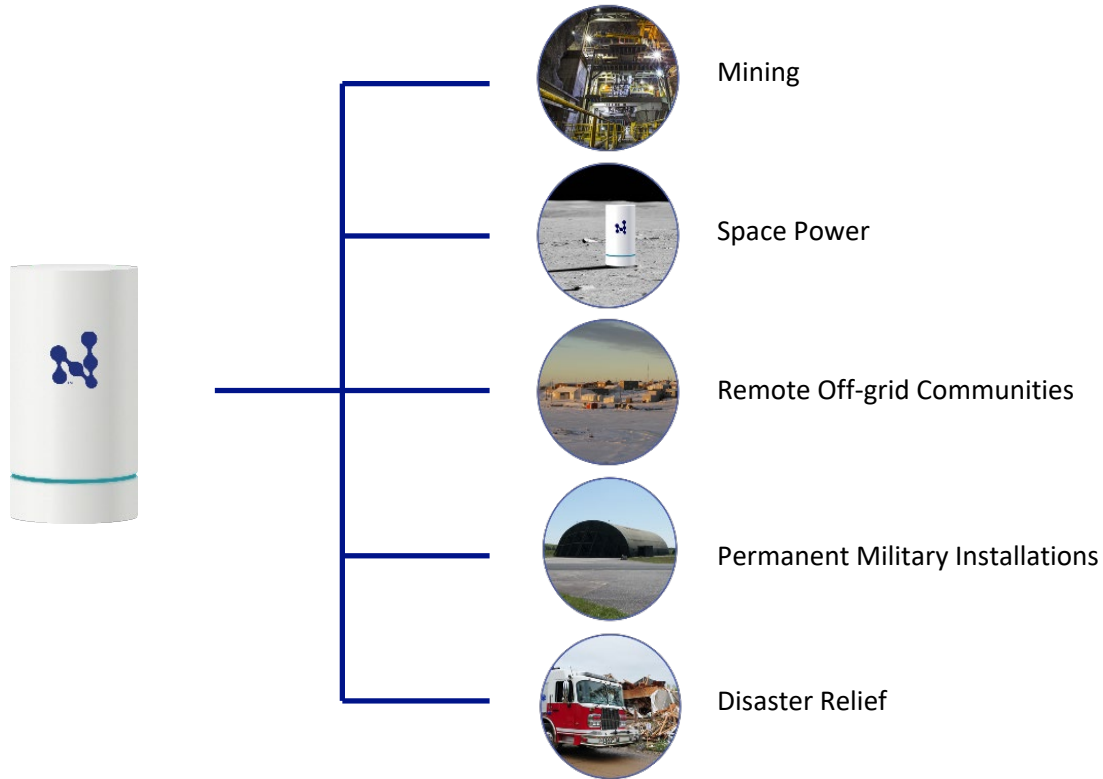

Collaboration on Advanced Materials and Manufacturing

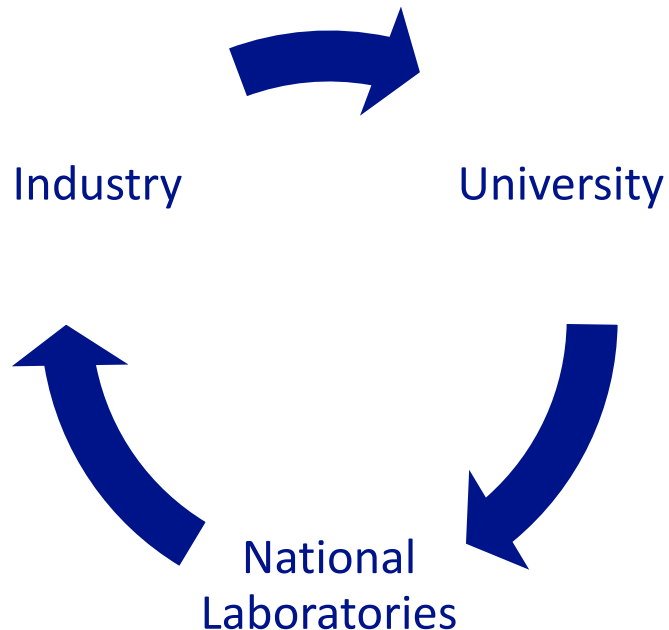

- EPRI Advanced Nuclear Technology Program
- Stack Metallurgical Group
- Oregon State University
- University of Illinois at Urbana Champaign
- MELTIO
- Idaho National Laboratory

Qualification of Advanced Materials for Nuclear Applications

Safety-related

- Extensive material data to support ASME Code Case (ASME Section II, Part D)
- NRC endorsement and 10 CFR 50.55a amendment

Nonsafety-related pressure retaining

- Extensive material data to support ASME Code Case (ASME Section II, Part D)

Nonsafety-related non-pressure retaining

- Necessary material data to qualify design for commercial operation

Opportunity to Collaborate on Material Qualification

- NSUF High Temperature Irradiation Program
 - TZM
 - Lanthanated Molybdenum
- Additive Manufacturing
 - Equivalence of weld buildup for ASME Code qualified materials
 - Fabrication with ODS Materials - R&D and Process Qualification



Derick Botha
Innovation Manager
dbotha@nuscalepower.com

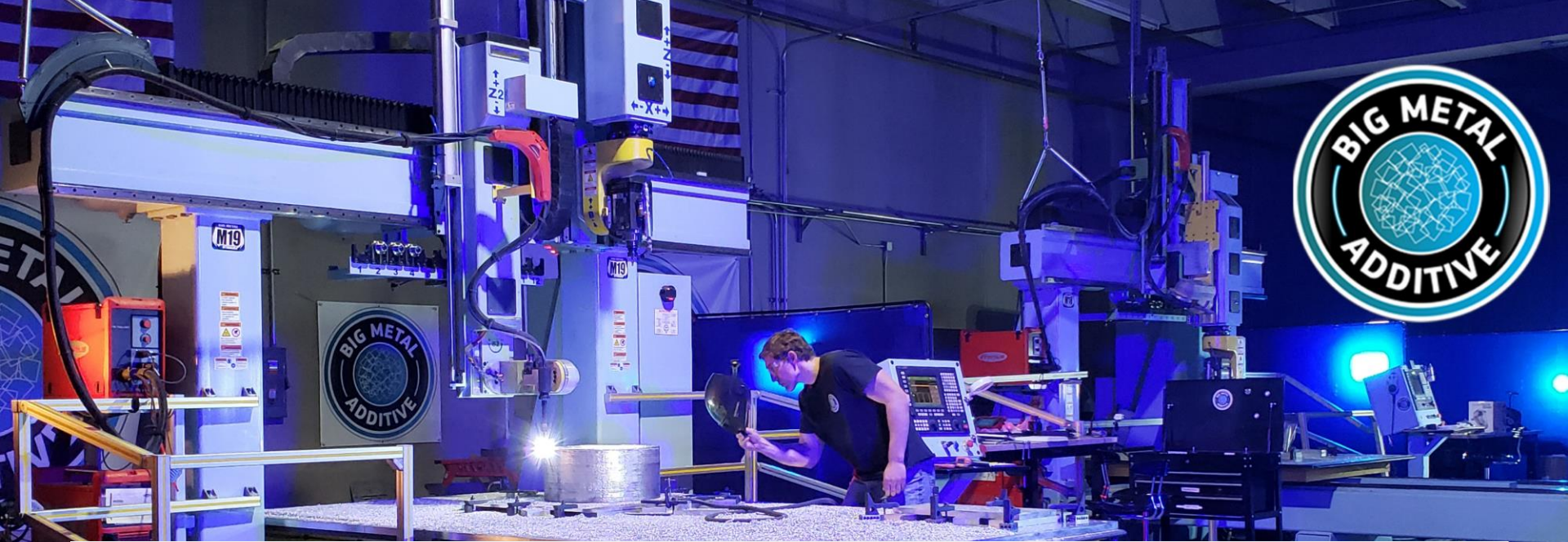

Design For “ _____ ”

**Idaho National Labs
Fission Battery Workshop
February 24, 2021**

**Slade Gardner, PhD
President, Big Metal Additive**

Our Business



Customer Prototypes

- New Functional Architectures
- Manufacturing Case Studies
- Full Scale Field Test Products
- Design Prototypes



Vehicle Bracket
Replacement Tool
Oversize Bracket
EV Battery Enclosure
Heavy Truck Bracket
27" Valve Handwheel
Aerospace Inlet

Design Demonstrations

- Optimized Designs at Industrial Scale
- System Integration Configurations



Customer Aluminum Parts

- Obsolete or Replacement Parts
- Fast Parts
- Improved Optimized Parts

AWS Certified Aluminum Alloys

- 2319, 5554, 5556
- Others by request

Industrial Metal Additive Manufacturing



Large Build Volume

- 6ft x 12ft Table
- Industrial Scale
- Manufacturing Flexibility

Multi-Axis Hybrid Process

- Dimensional Control
- Higher Quality
- 5-Axis Machining

Manufacturing Grade

- Intermediate Inspections
- CNC Machining
- 12 Position Tool Changer
- On The Fly Design Changes Possible



BMA Engineering Advantages

Industrial Software

- Part Analysis
- Engineering CAD Model
- Optimization and Design Revs
- Analysis and Redesign

Expert Programming

- Manufacturing Grade Tool Paths
- Tailored To Part Design
- Development Flexibility

Full Simulation

- Validation Of Process
- Collision & Interference Checks
- Visualization Of Finished Article

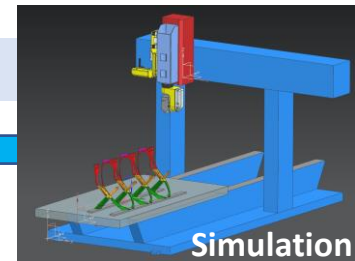
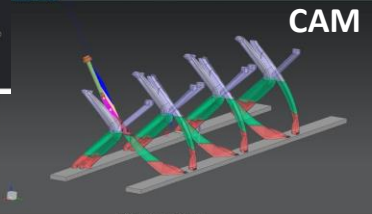
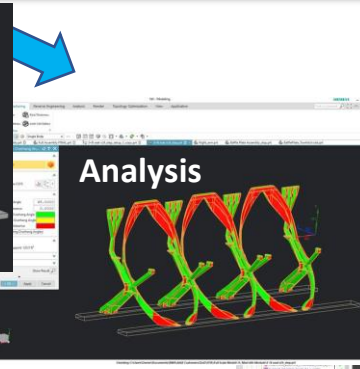
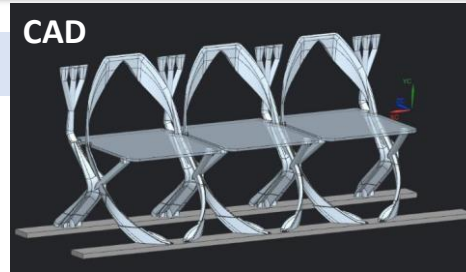

BMA Hybrid AM Advantages



5 Axis Metal Deposition

- Full Articulation Deposition
- Horizontal Unsupported Builds
- Customized Tool Path Strategies

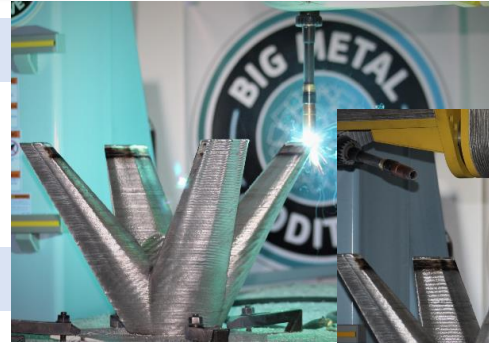

Every Layer Of Metal Is Machined

- Clean Metal Substrate For Every Deposition
- Precisely Defined Layer Height
- Flat Surface For Every Layer
- Quality, Quality, Quality



5 Axis CNC Machining

- Surface Machining
- Finishing Parts And Tolerance Surfaces
- End Mill, Ball Mill, Chamfer Mill, Keyhole Cutter, Fly Cutter, Convex Radius Cutter



Hybrid AM Machining Advantages



Complex Challenging Geometries



Adaptable, Configurable Geometry



Field Test Articles



From July 13-23, 2020, the Amphibious Vehicle Test Branch at Marine Corps Base Camp Pendleton, California, conducted a proof-of-concept test to identify the capabilities and limitations of the ship-to-shore connector to determine the feasibility of its operational employment for further development of the technology. As such, testing was limited to a demonstration of the main phases in employing the system in a protected harbor environment including: field assembly, deployment, loading, water mobility and stability, emergency release, unloading, and recovery of the system. The non powered ship-to-shore connector was towed by organic Marine Corps assets. Nine subject matter experts evaluated the expendable ship-to-shore connector on eight criteria focused on use in an operational field environment, and all subject matter experts unanimously found the performance favorable for all criteria considered—the approach has a great deal of merit and warrants additional research and development.





Ship to Shore Connector

Efficient Design and Construction

- Minimal bill of materials
- Hardware familiar to Marines
- Aluminum plate and typical fabrication
- Expendable over exquisite (Commandant's Planning Guidance)
- Designed to satisfy loads and environment
- Designed for speed of production, mission tailorable

Specialized structures built with hybrid AM

- Ship to shore connector = 5 rafts
- Raft = 5 sponsons + deck plate
- Could be built at or near point of need
- Produced at the height of COVID-19
 - Emphasizes ability during crisis
 - Supply chains disrupted
 - Service community in chaos

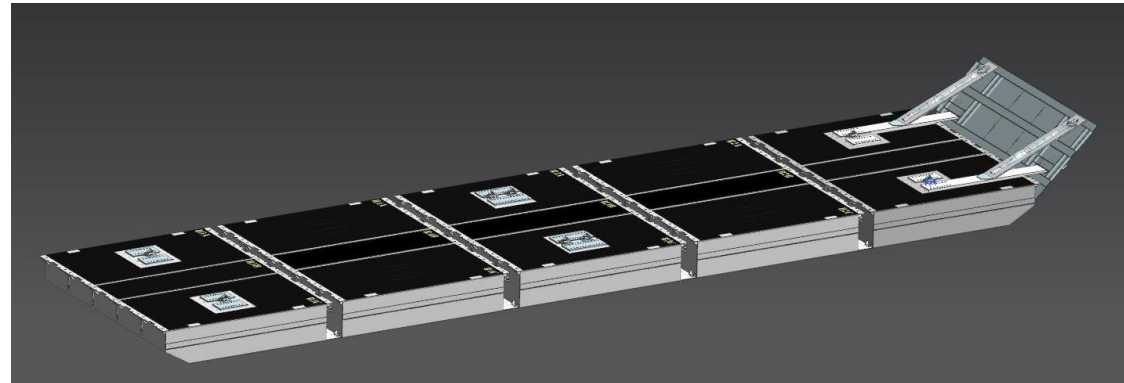



Manufacturing Speed and Necessity

Seating Modules

- Custom to application
- Accommodates ruck sacks
- Demonstrates 3 design types
- **Generative Engineering**

Padeyes

- **Optimized for system cost and performance**
- Extends plate stock to complex structure

Bow Plane Supports

Mooring Cleats

Seating Modules for 15 Marine Transport



Padeyes for Connecting Sponsons/Rafts



Bow Plane Struts and Supports



Mooring Cleats

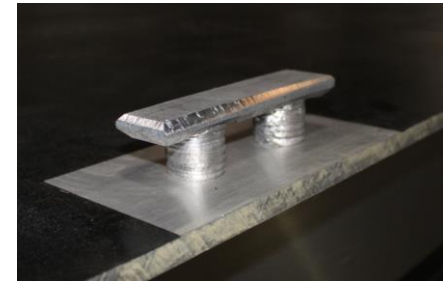

Internal Features

Padeye

- Standard marine rigging hardware
- Typically steel and welded on
- Aluminum padeye required
- Built directly on end cap plate

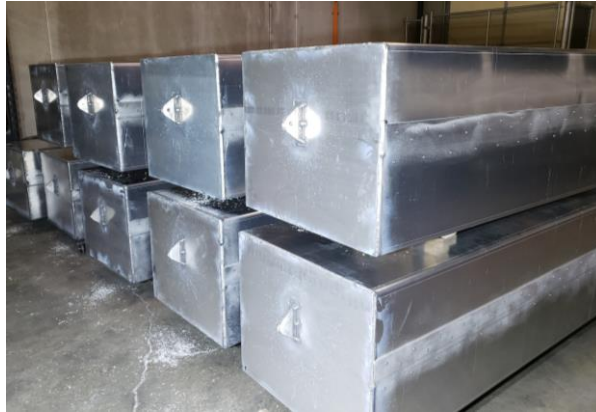

Optimization

- Stainless steel shackles used with padeyes
- Most **affordable** shackle selected to meet load requirement
- Padeye sized to accommodate shackle and **maximize performance**

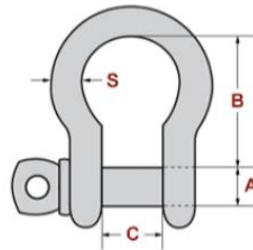

Pin Size
Throat Opening

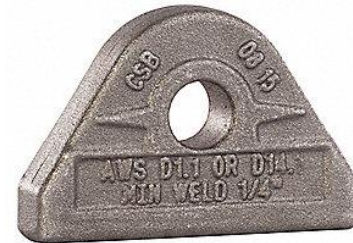

Base width
Base length
Hole diameter
Outer diameter
Height
Thickness



Maximize Design to Meet Requirements

Padeye Performance Calculator

- Bearing strength
- Tearout strength
- Base shear strength
- Base tensile strength

Design features

- 5" long padeye base
- 2.25" outer diameter
- 0.79" thickness
- 0.67" through hole
- Footprint increased gussets

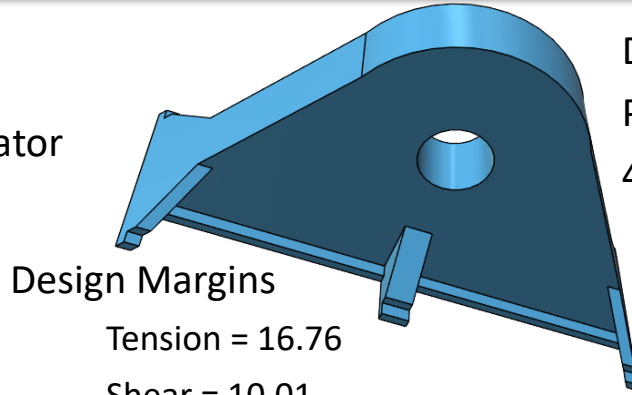

Design Margins

Tension = 16.76

Shear = 10.01

Bearing = 3.01

Tear out = 3.17

Design Load 2,314 lbs

Proof Load 3,000 lbs

4 test articles **PASSED**

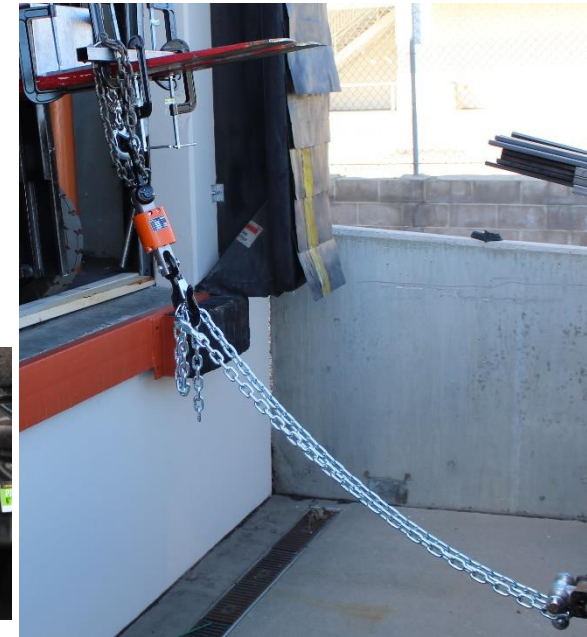
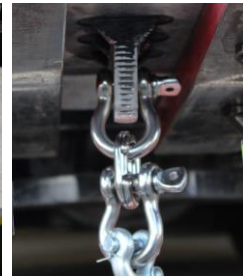

Design Tools - Generative

Loads, Exclusion Zones,
Materials and Retained
Geometry

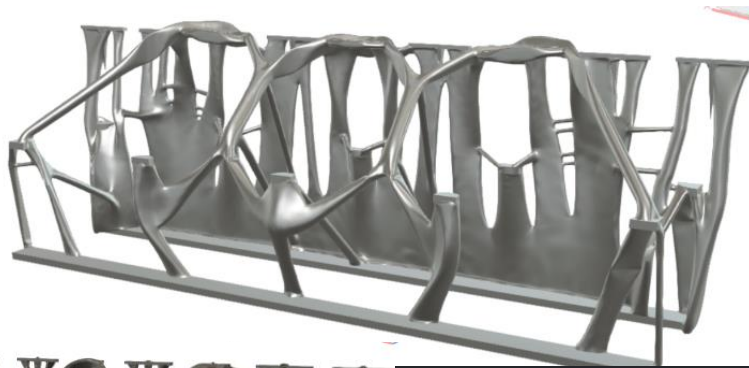

Several Candidate Results

Provides Design **Inspiration**



‘Features’ Extracted from
Several Different Results

Final Design Produced ‘by
Hand’

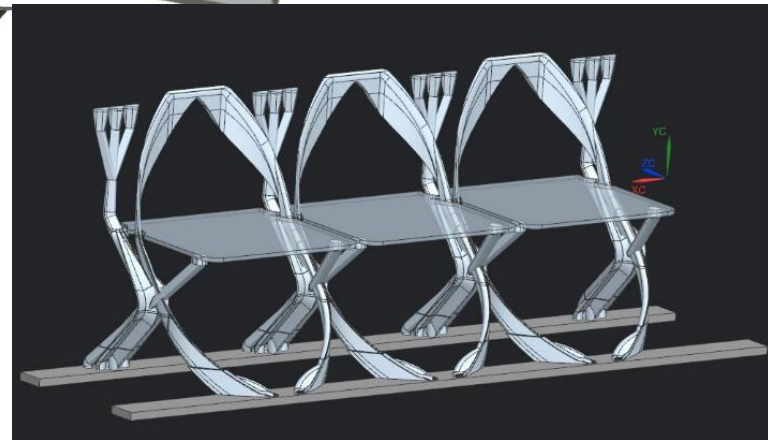

Complex Designs

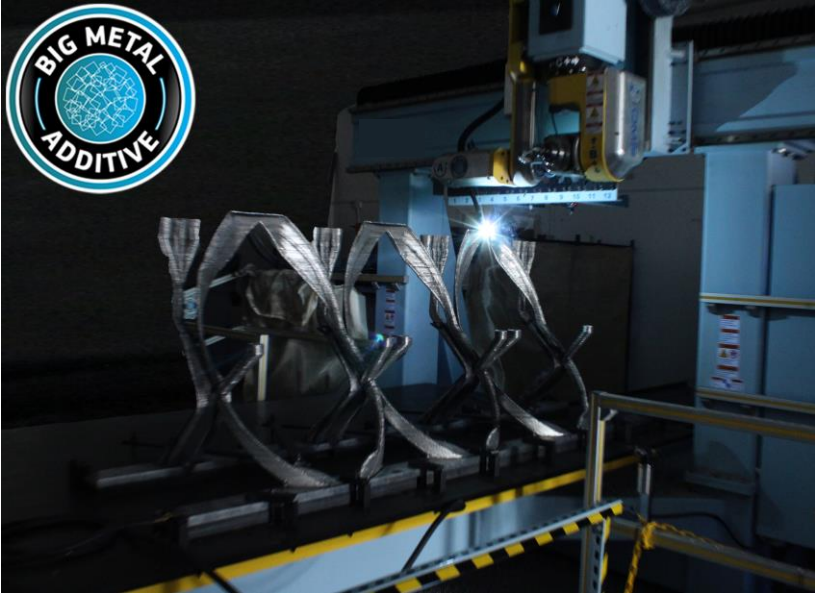

Field Test Articles

Unmanned Vehicle manufacturability:

- define and develop modular system fabrication and assembly technologies
- conduct related materials research
- Reconfigurable AM technologies
- 21" diameter, 98" long

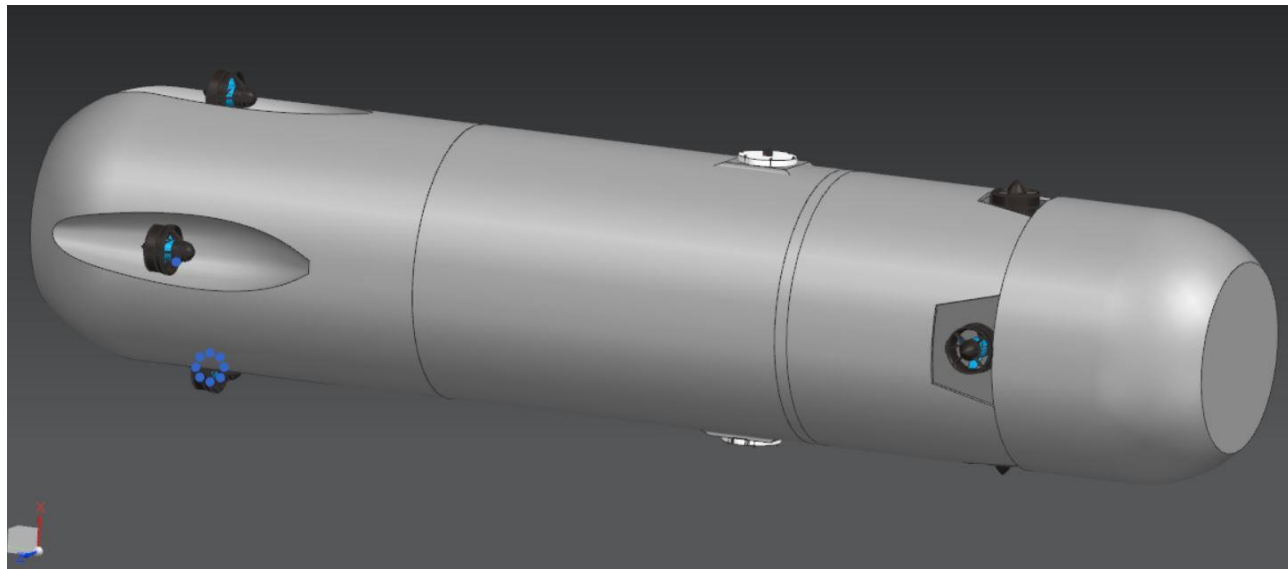
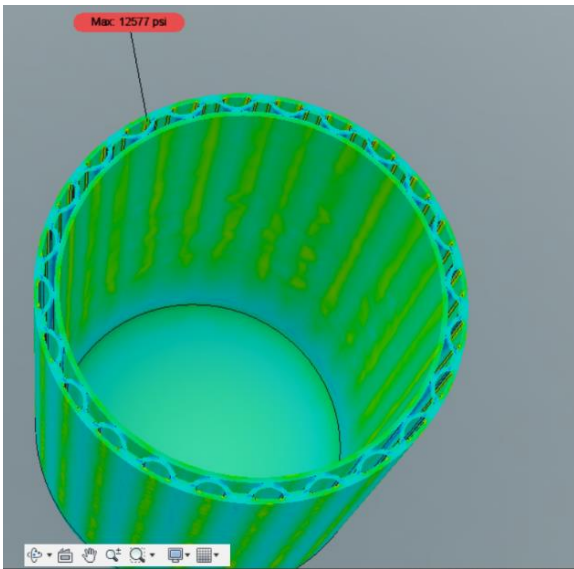

Air Taxi

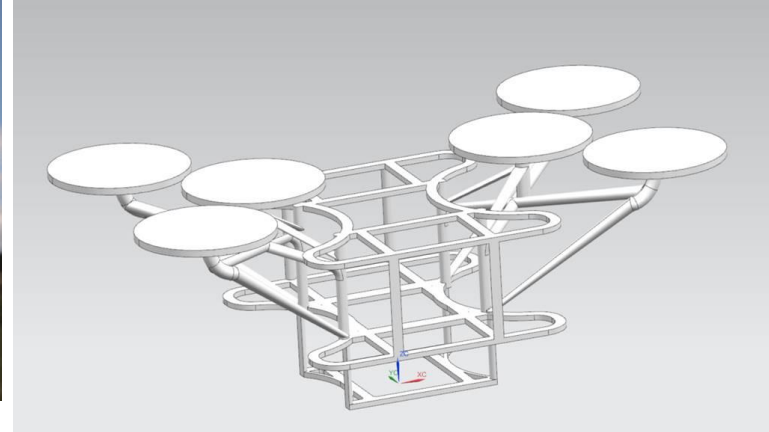
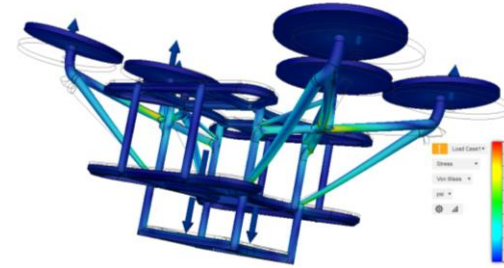

Air Taxi 2.0



Weight
Durability
Infrastructure

Cost
Producibility
Market Growth

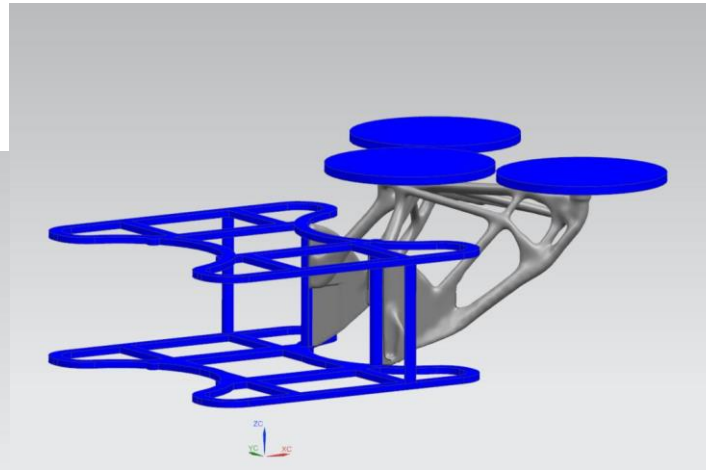
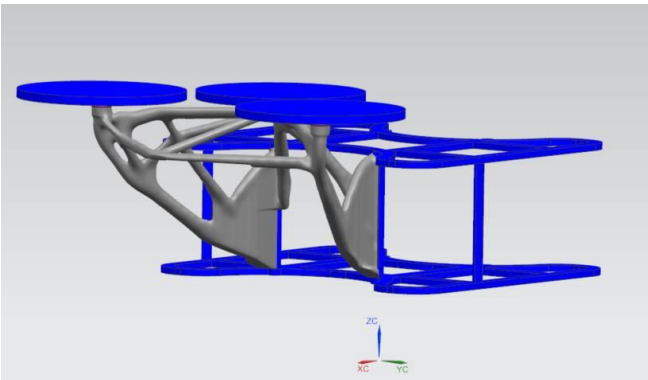

Style → WOW



Performing Art



Multi-Functional Satellite Structure



Antenna boom
Waveguide
Fluid passages
Cable races

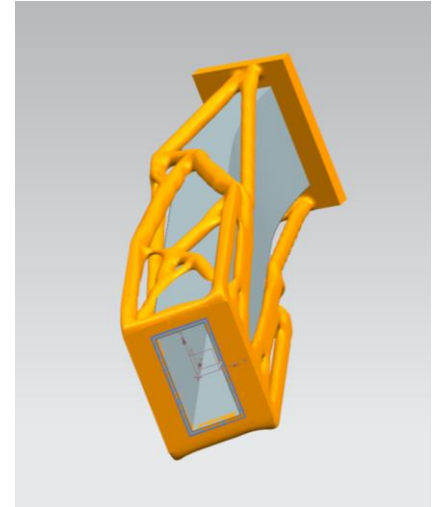

Performing Art



Multi-Functional Satellite Structure

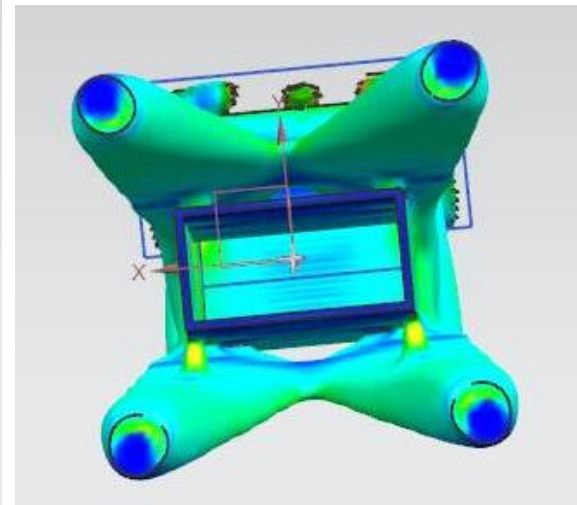
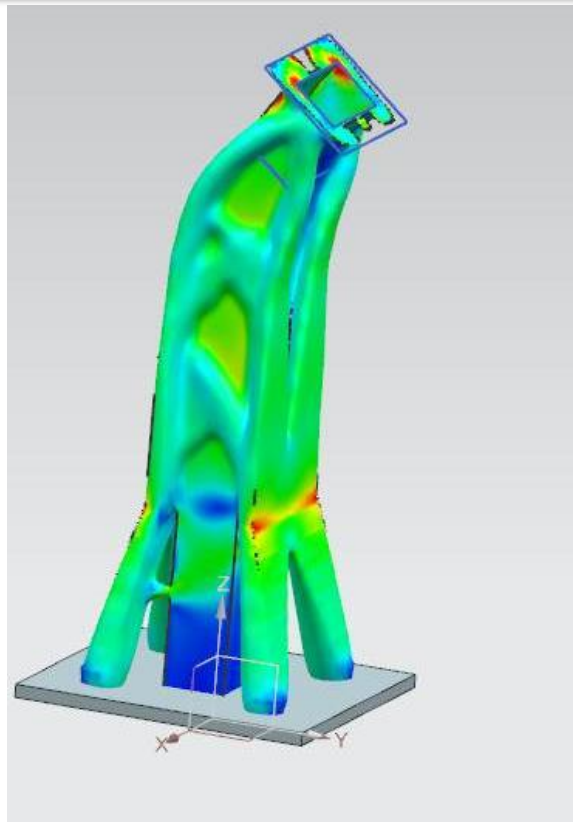

Design For “_____”



Load

Producibility

Lead Time

Integration

Configurability

Re-configurability

Survivability

Volumetric Efficiency

Weight

Redundancy

Assembly

Installation

Thermal Loads

Cost

Multi- Functionality

Digital Inventory

Surge Manufacturing

_____ ?

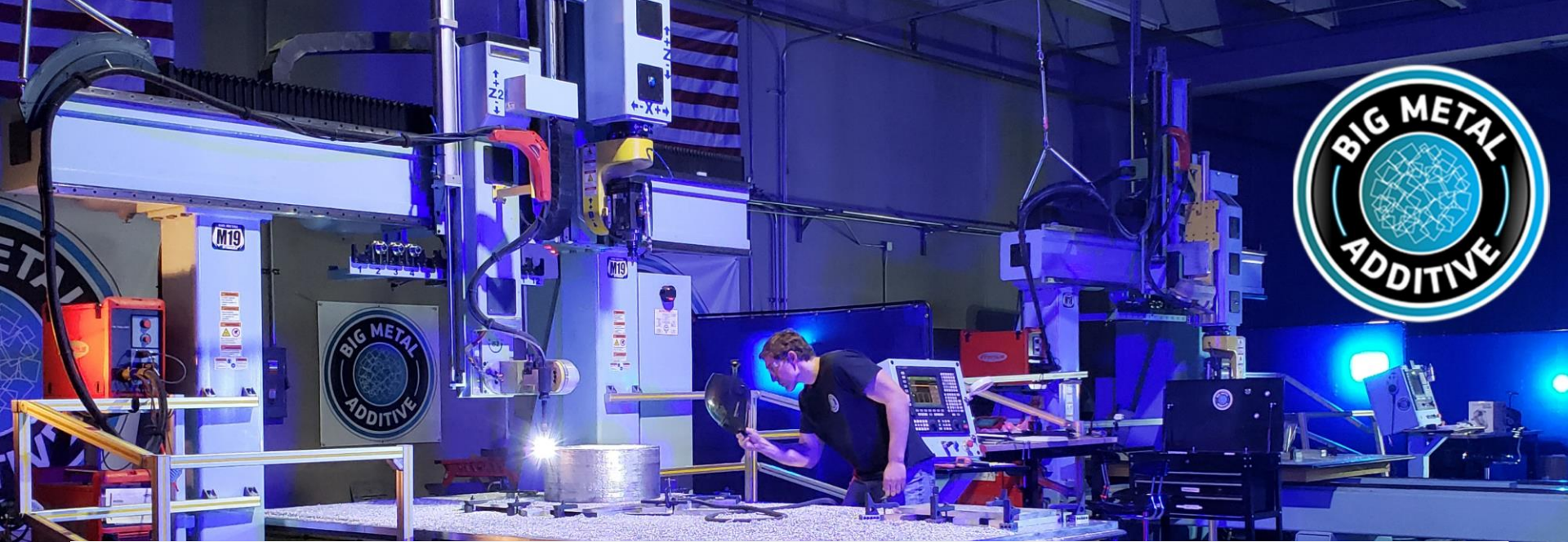

Big Metal Additive: unique, multi-axis hybrid metal additive manufacturing

Large Complex
Metal Parts
FAST

- Large complex metal parts made quickly and accurately
- Sophisticated structures accelerate final product integration and assembly
- New optimized designs
- Functional prototypes
- 'Bionic' and 'biomimetic' structures
- Finish machined surfaces
- Work directly with native CAD models
- Aerospace grade aluminum
- Generative engineering design
- Casting and forging part replacements

A Paradigm Shift in Manufacturing as Opportunity for Fission Battery Success.

Isabella J van Rooyen

National Technical Director: DOE-NE Advanced Methods for Manufacturing



LRS/MIS-21-01025

Technology Innovations for Fission Batteries: Fission Battery Webinar Series; February 24, 2021

Advanced Methods for Manufacturing (AMM)

Vision

- To improve and demonstrate the methods by which nuclear equipment, components, and plants are manufactured, fabricated, and assembled by utilizing 'state of the art' methods

Goal

- To reduce cost and schedule for new nuclear plant construction
- To make fabrication of nuclear power plant (NPP) components faster, less expensive, and more reliable

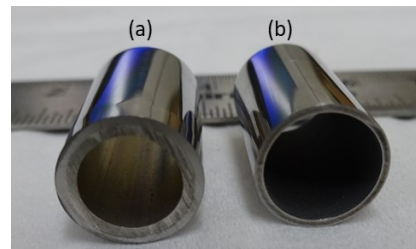

Fuel tubes produced by cold spray

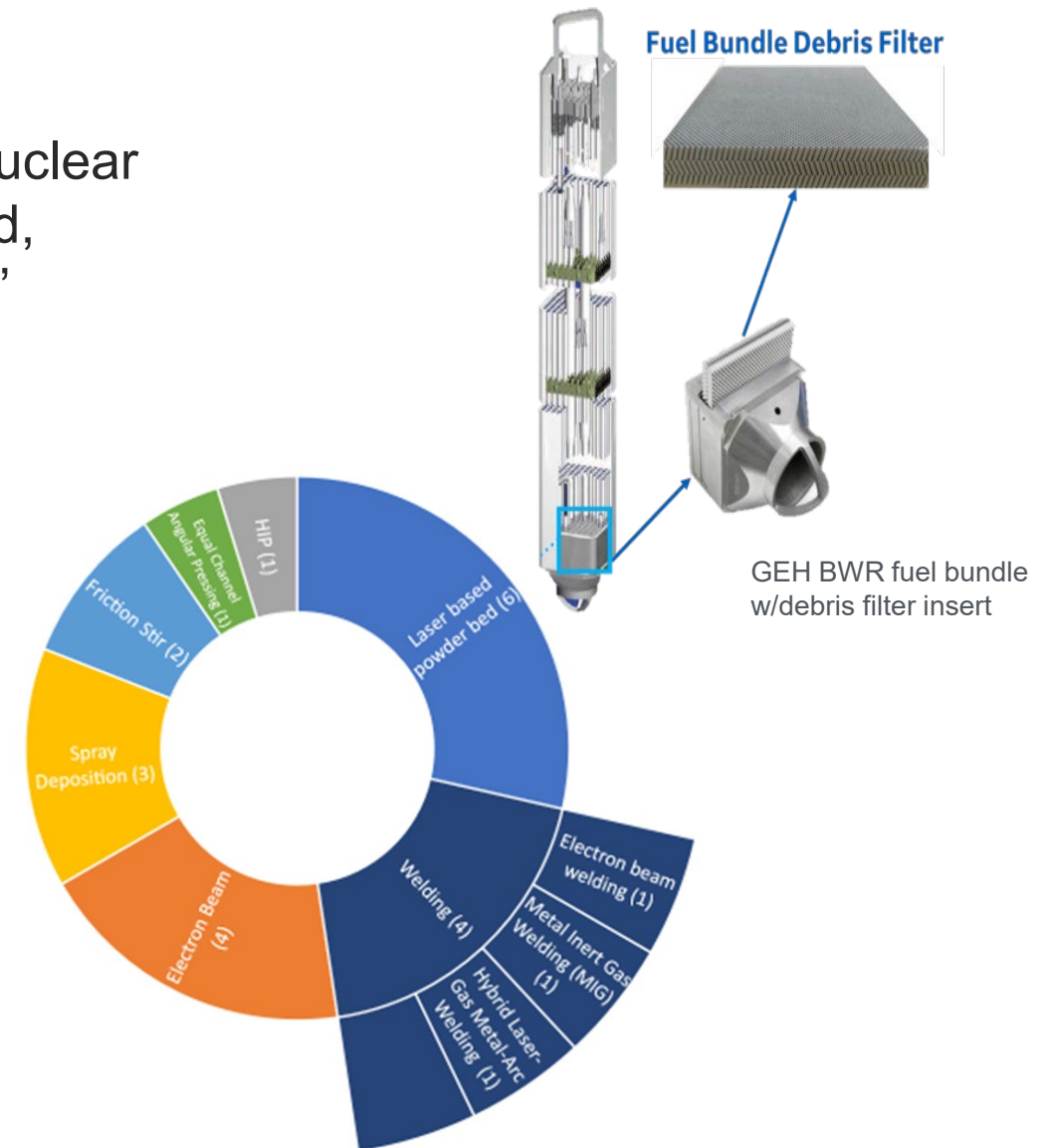

DOE-NE AMM Focus Areas: FY2021



Factory and Field Fabrication Techniques

High Speed & High Productivity Welding
Welding technologies for large weldments and fabrications

Dissimilar Materials Joining
Robotics and advanced automation



Modular Manufacturing

Fabricated forgings
Factory fabrication of piping systems

PM-HIP



Advances in Manufacturing Processes

Additive Manufacturing of metals
Surface engineering

Metamorphic Manufacturing
Advanced sensors



Improved Concrete Inspection, Acceptance, and Construction Methods

Advances and innovation in high strength concrete and rebar
NDE and field inspection for first time quality assurance and repair

Improved methods to facilitate the curing of concrete

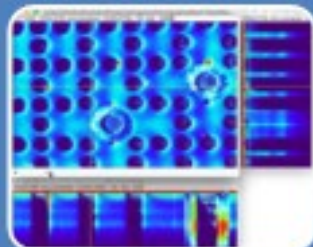

New Advanced Manufacturing Technologies for Qualification and Certification to Accelerate Licensing

Advanced Manufacturing Methods Qualification approaches
Verification and validation technologies
Advanced Manufacturing Codes and Standards

Big data
Digital Thread and Digital Twin



Advanced Integrated Fuel System Concepts

Advanced thermal processing approaches

Integrated manufacturing methods

Evaluate AMM Program Award Impact (NEET Awards 2011-2019)

DRAFT

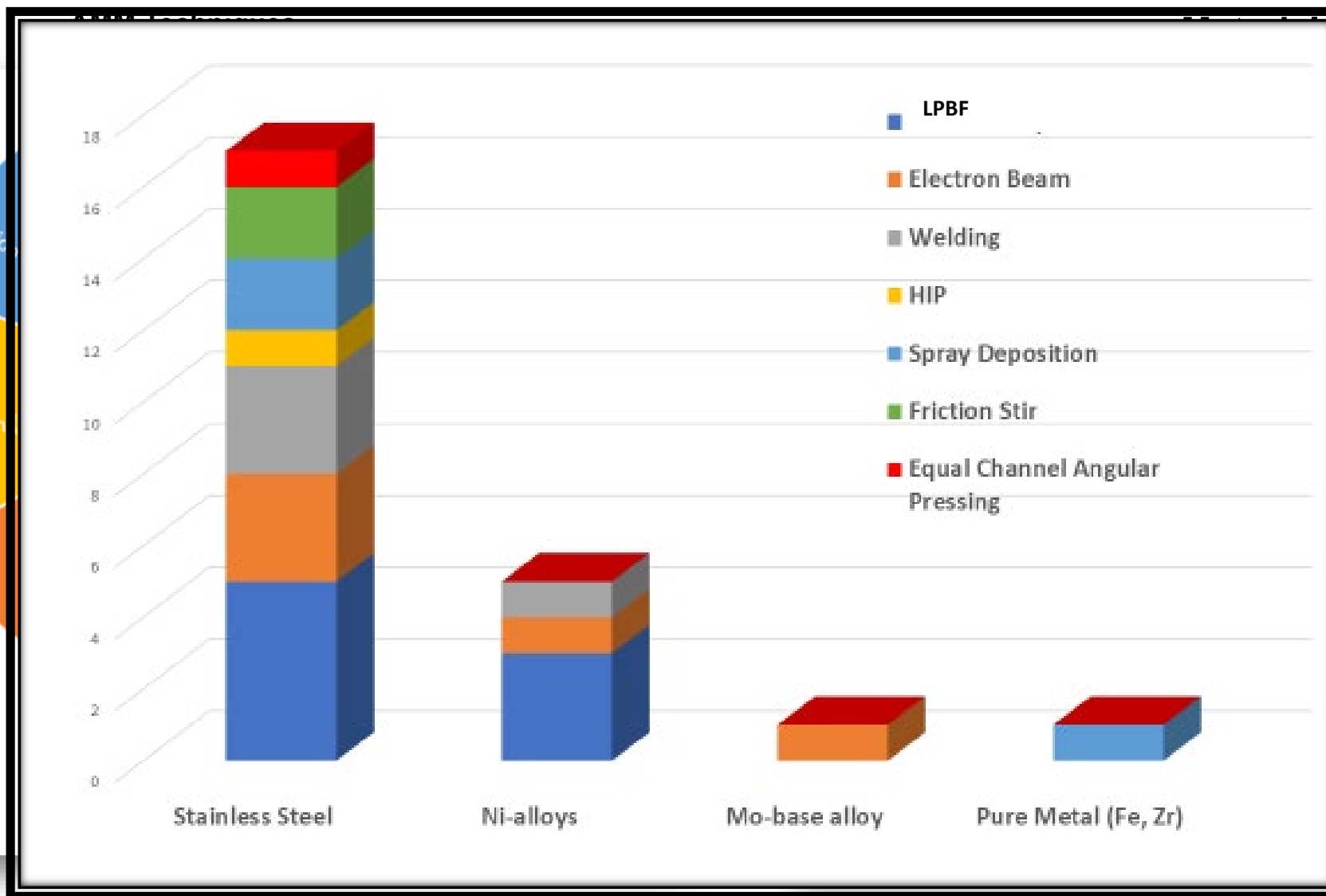

Gaps or Technology Challenges

Prioritizing Methods and Materials
Complex set of needs
Risk reduction methods
Speed to industry deployment
Qualification Processes
Maturity Level

- Performance data in “nuclear” environments
- How do we measure or gauge applications of new AMM?
 - Technology readiness level
 - Qualification routes
 - Standards/Codes
 - Risks
- Determining requirement & performance specifications for different manufacturing process domains
- How do we measure & communicate the impact of our research (especially earlier TRL)?
- Cybersecurity in:
 - Digital Engineering
 - Machine Learning approaches
 - Big Data/Artificial Intelligence Applications
 - Automated Manufacturing
 - In-situ monitoring
 - Embedded sensor

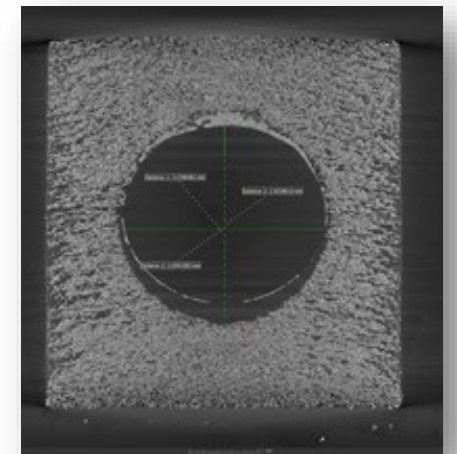

Manufacturing and Fission Battery Needs

Repeatable
Decrease uncertainties
Predictable & Measurable Risks

Modular
Integrated Manufacturing
Factory built?
On-site built?
On-site repair

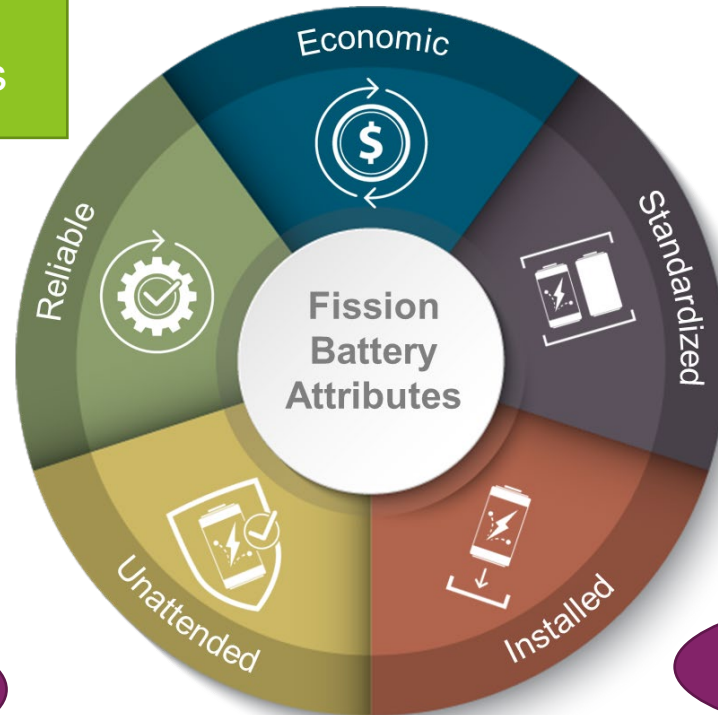

Digital
Twins

Embedded
Sensors

Containment
technologies

Gradient
Materials

Coatings

Topology
Optimization

Qualification process
re-imagined

Supply Chain
Sensitivities

Design for AMM

Industrialization
/Upscale

Manufacturing Process Digital Twin Conceptual Architecture

Example

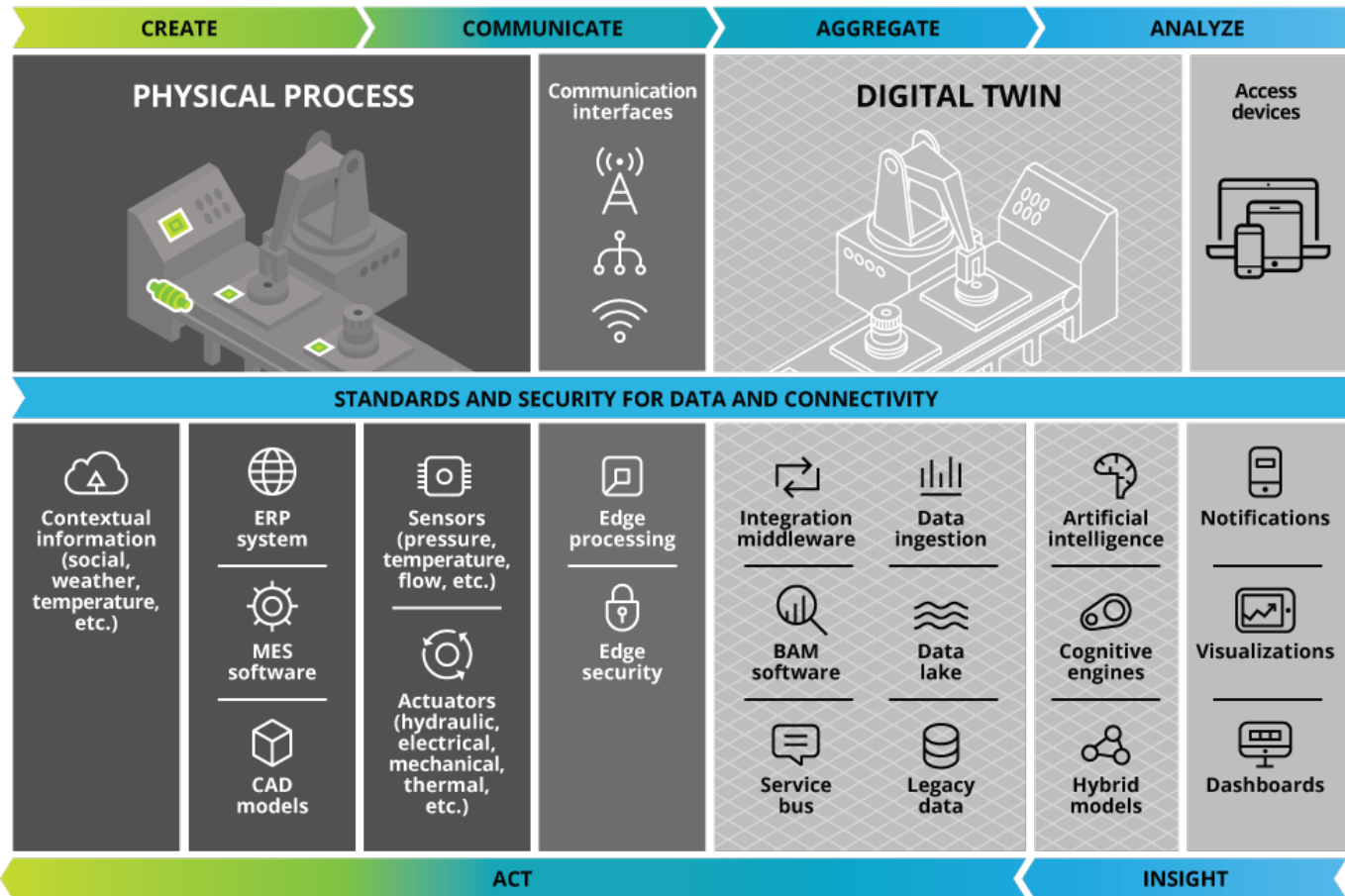

Major challenge in undertaking a digital twin process:

- determining optimal level of detail in creating a digital twin model.

Only a portion of the product life cycle:

- manufacturing process
- properties
- performance

Product

Integrated system

Operation/ use

Supply chain management/risk

Digital Twin Business Values

Table 1. Digital twin business values

Category of business value	Potential specific business values
Quality	<ul style="list-style-type: none">• Improve overall quality• Predict and detect quality trend defects sooner• Control quality escapes and be able to determine when quality issue started
Warranty cost and services	<ul style="list-style-type: none">• Understand current configuration of equipment in the field to be able to service more efficiently• Proactively and more accurately determine warranty and claims issues to reduce overall warranty cost and improve customer experiences
Operations cost	<ul style="list-style-type: none">• Improve product design and engineering change execution• Improve performance of manufacturing equipment• Reduce operations and process variability
Record retention and serialization	<ul style="list-style-type: none">• Create a digital record of serialized parts and raw materials to better manage recalls and warranty claims and meet mandated tracking requirements
New product introduction cost and lead time	<ul style="list-style-type: none">• Reduce the time to market for a new product• Reduce overall cost to produce new product• Better recognize long-lead-time components and impact to supply chain
Revenue growth opportunities	<ul style="list-style-type: none">• Identify products in the field that are ready for upgrade• Improve efficiency and cost to service product

Source: Deloitte analysis.

Embedded Sensors & Non-contact Sensors

- Advanced Sensors and Instrumentation (ASI): <https://www.energy.gov/ne/nuclear-energy-enabling-technologies/advanced-sensors-and-instrumentation>
 - Sapphire Single-Mode Fiber Development Towards High-temperature Radiation Resilient Sensors
 - Acoustic Sensors for In-Core Measurements
 - Aerosol AM strain Gauge
 - passive and active sensors capable of measuring temperature, thermal conductivity, strain, and neutron flux inside the reactor core.

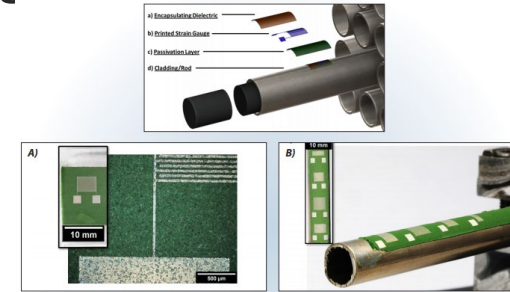

For more information:
Patrick.Calderoni@inl.gov

- Advanced manufactured dosimeters (AMDs): cost-effective, miniaturized, performance-enhanced alternative to standard dosimetry for characterization of neutron flux in irradiation experiments and demonstration facilities.

NEEDS:

- Wireless sensors
- Embedded
- Miniaturization
- Multi-properties
- Real time

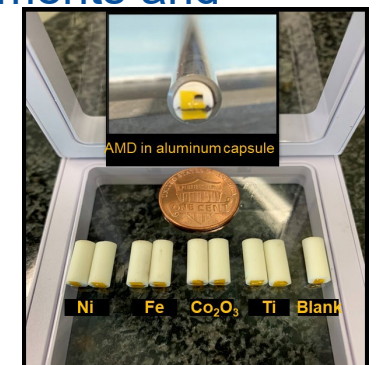

State of Practice in Reinforced Concrete Construction



Reinforced Concrete (RC)

Wikipedia

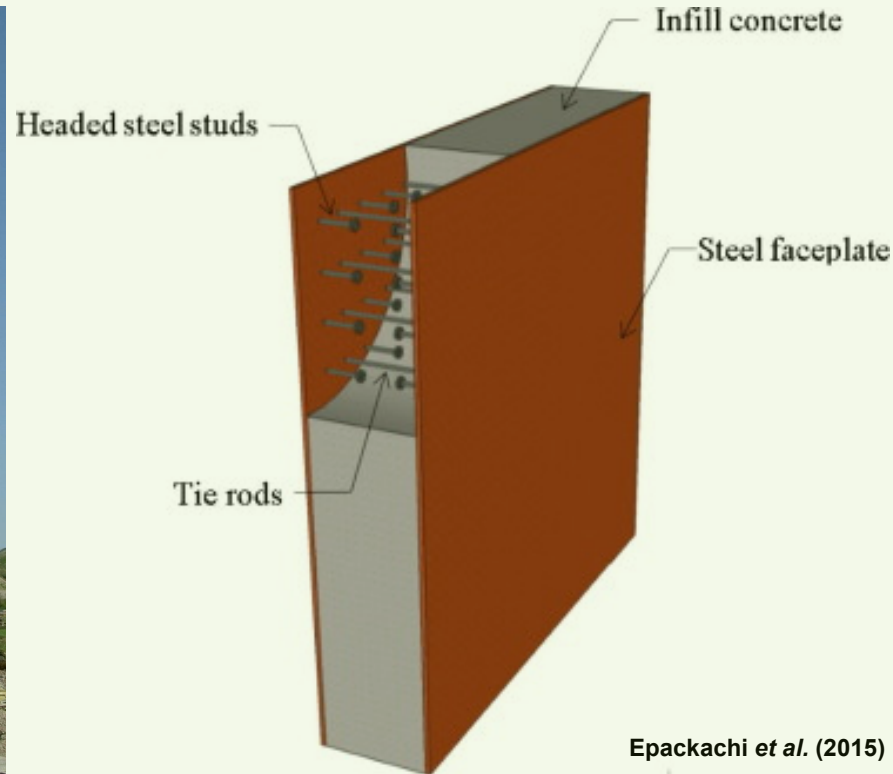

Steel-plate Composite (SC)

Epacakchi et al. (2015)

Nuclear construction



Precast Concrete

<http://www.windfarmbop.com>

Non-nuclear construction

Technological Innovations in Reinforced Concrete

- Reinforced concrete structures may have to be used as secondary/tertiary containment for fission batteries
- Need technologies that provide adequate structural performance, modularity, rapid assembly, and radiation shielding
- Some innovations include:
 - Advanced manufacturing of reinforcement cages including development of materials that can replace steel and can be additively manufactured
 - Manufacturing ‘foldable and transportable’ reinforced concrete structures?
 - ‘Smart’ concrete with embedded sensors
 - Concrete with superior radiation shielding properties to reduce (or eliminate) EPZs

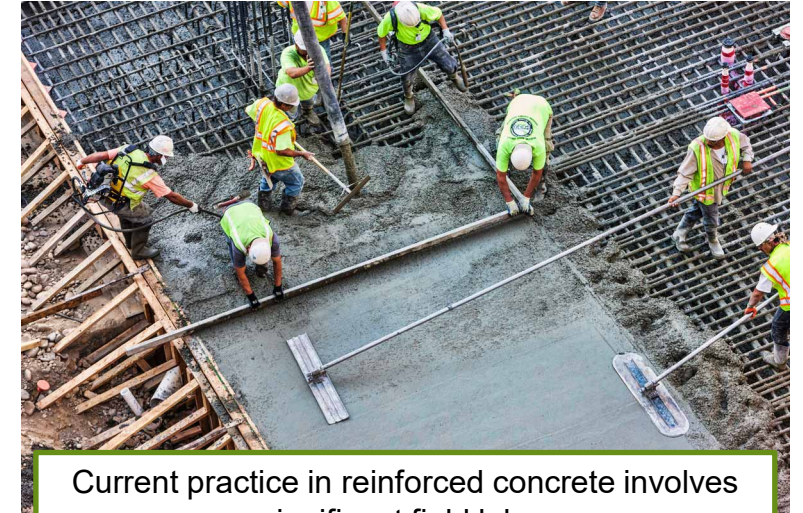

Current practice in reinforced concrete involves significant field labor

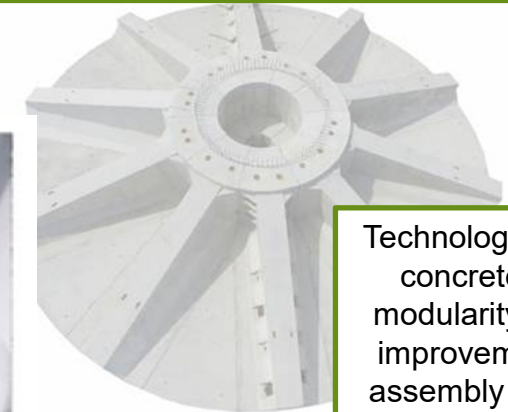
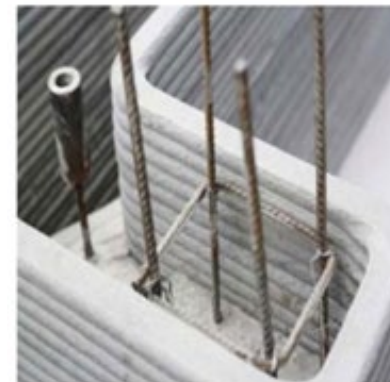

Technologies like precast concrete offer some modularity but still need improvements for rapid assembly and increased factory production through additive manufacturing

Engineered Gradient Materials & Composition

- Multi component replacement with one integrated design (eliminate weld) and thin functional gradient layer
 - Ni-Alloy N; Zr-Cr; Grade 91-316L
 - Interface behavior
- Thermal Barrier Coatings
- Material composition for additive manufactured processes
 - Materials are designed for example to enable the fabrication processes, e.g flowability for casting compositions
 - Is there a specific minor composition adjustment necessary for Additive manufactured materials?
- Surface behavior, corrosion properties and irradiation behavior of additive manufactured components
- AMM provides opportunities to discover and develop new materials

SiC/Cu graded material

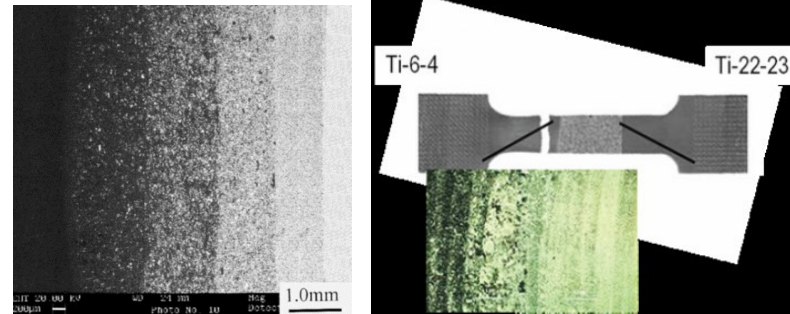

[Y. -H. Ling, Journal of Nuclear materials, 303 (2002) 188-195]
[Advances in Laser Deposition Technology and Applications R. Grylls, T. Marchione, D. Keicher; ALAC Conference Proceedings, 2006.]

Qualification Processes

Categorization of manufacturing processes?????
 What makes it advanced manufacturing????

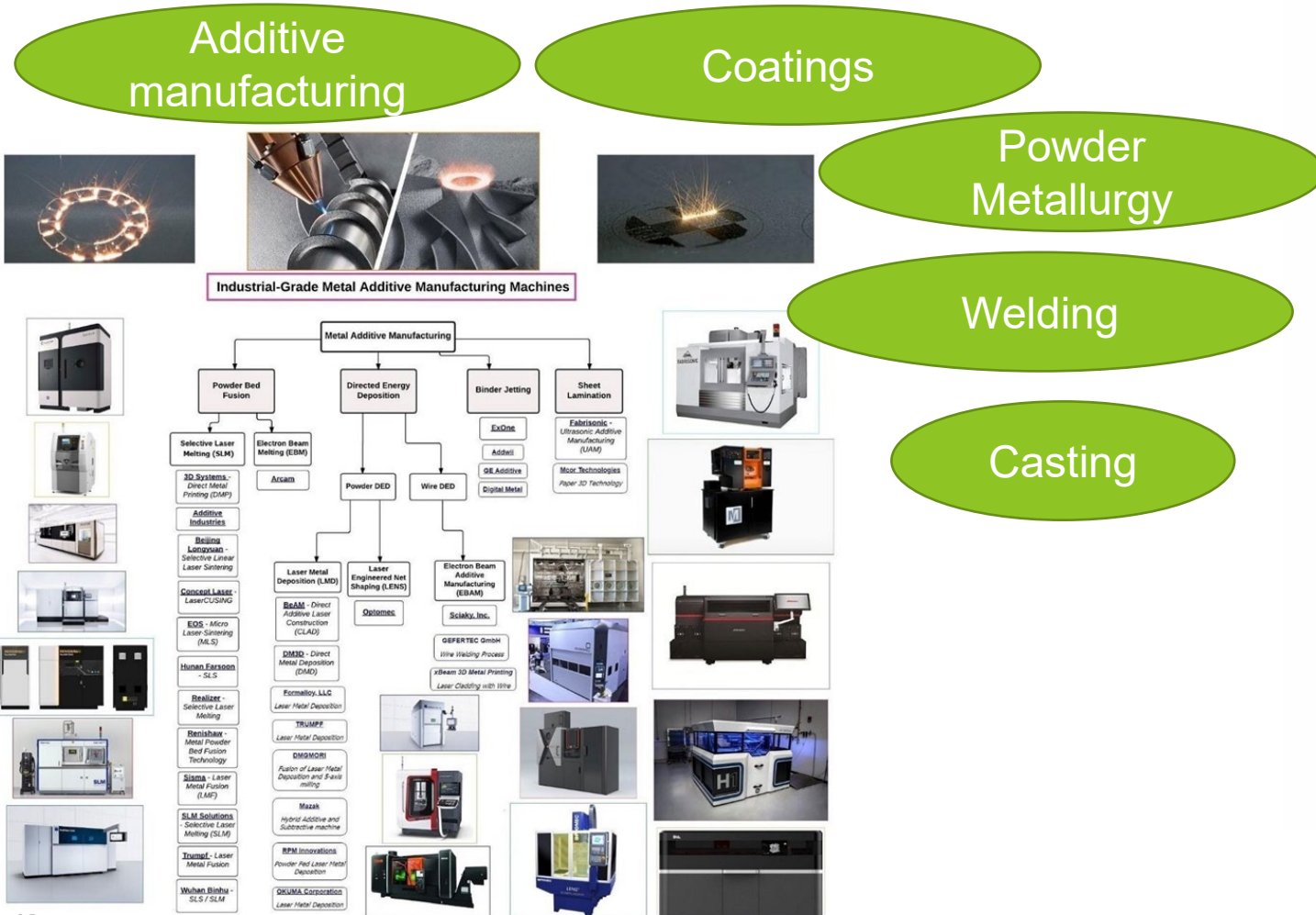

SAVE THE DATE

GAIN-EPRI-NEI
Advanced Methods for Manufacturing
QUALIFICATION WORKSHOP



AUGUST 24-26, 2021
 INL Meeting Center, 775 MK Simpson Blvd, Idaho Falls, ID 83401

PURPOSE:

Develop an integrated approach to the AMM qualification process for materials and components and identify current blind spots.

OBJECTIVES:

- Understand current qualification processes
- Create novel approaches to process qualification
- Identify "what" industry needs in product, properties, and performance
- Identify areas in the AMM Supply Chain qualification that are lacking
- Identify possible synergistic qualification needs from industry through performance requirements
- Identify opportunities to shorten qualification by using AMM techniques
- Identify opportunities to reduce project cost by using AMM techniques

Check out the workshops tab at <https://gain.inl.gov>



High Impact Manufacturing Technology Challenges

- Design approaches for manufacturing
 - More qualified materials are needed by reactor developers to allow for design flexibility and to meet performance targets.
 - Optimized process modeling and AI
 - Interface design
 - Residual stresses relationships to design features
 - Topology optimization
- Develop and qualify high strength, corrosion and radiation resistant materials for molten salt reactors
- Accelerate qualification (new paradigm?)
 - Verification of quality & validation of modeling tools: specific manufacturing process modeling
 - “New” material discovery (or is it adoption of lessons learned from other disciplines)
 - High-throughput testing and characterization
 - Verification of quality & validation of modeling tools: specific manufacturing process modeling
 - Acceptance protocols for high temperature reactor components fabricated by advanced manufacturing methods
 - Integrated shared databases
- Compact Heat Exchangers
 - Develop scientific understanding of processing-properties relation for enhanced diffusion bond properties
- Large component fabrication and welding, Size limitations (Scalability – size, volume)
- Sensors:
 - Radiation tolerant sensors
 - Miniaturization of sensors
 - Integrated manufacturing processes
- Thermal barrier coatings: Interface designs to prevent scaling, functional materials, isolation



Idaho National Laboratory

Technology Innovations for Fission Batteries: Fission Battery Webinar Series; February 24, 2021

WWW.INL.GOV



EXTRA SLIDES

Additive Manufacturing Projects – Code Case

Integrated Computational Materials Engineering & In-Situ Process Monitoring for Rapid Qualification of Components Made by Laser-based Powder bed Additive Manufacturing Processes for Nuclear Structural

Award Number: DE-NE0008521

Award Dates : 10/2016 to 06/2020

PI: David Gandy

Team Members: ORNL, Westinghouse, Rolls-Royce



Figure 1a. A 316L SS Pipe Tee fitting is being produced via LPB-AM.

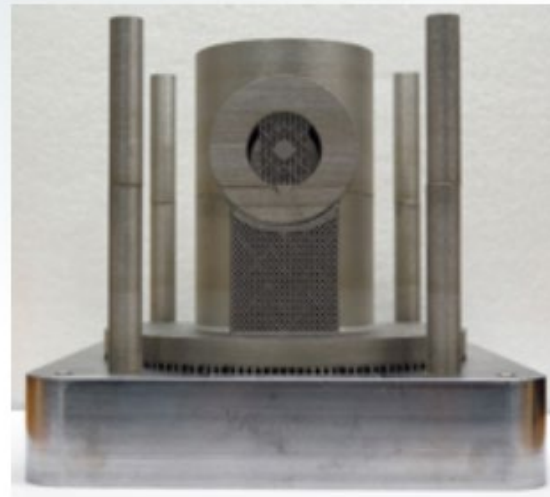

Figure 1b. A 316L SS section of a valve body was produced via LPB-AM.

- Working with ASME Special Committee on Additive Manufacturing and BPV-III to develop and submit Data Package and Code Case (with Westinghouse)
 - ASME Special Committee has drafted Guideline document for AM welding of 316L SS.
- Data Package finalized
- **Code Case submitted August 2020**

Enhancing irradiation tolerance of steels via nanostructuring by innovative manufacturing techniques

Introduction

Nanostructuring through severe plastic deformation (SPD)

High pressure torsion (HPT)

Equal Channel Angular Pressing (ECAP)

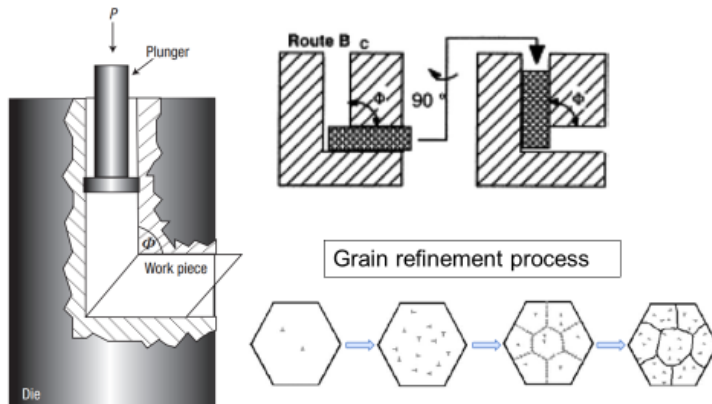
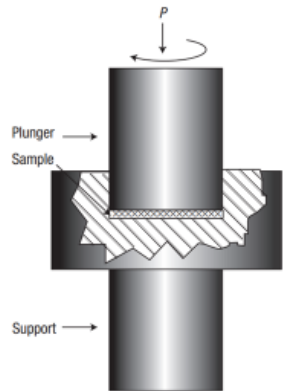

-Valiev, Ruslan. "Nanostructuring of metals by severe plastic deformation for advanced properties." *Nature materials* 3, no. 8 (2004): 511-516.

5

AMM TECHNICAL REVIEW MEETING (FY-20) DEC 2 - 3, 2020



Haiming Wen (Missouri S&T)

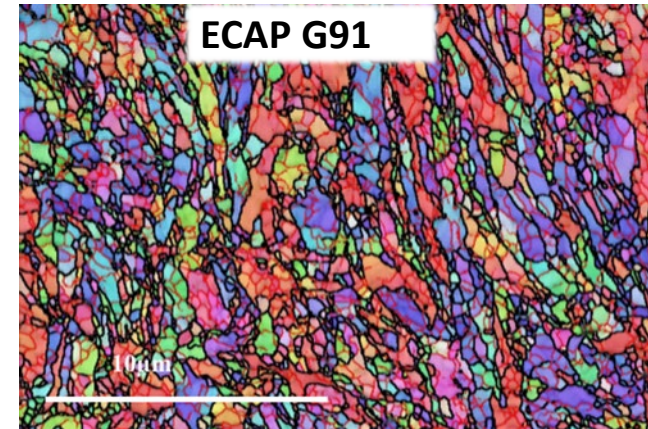

Mechanical Properties of Nanostructured Steels

Vickers Hardness: HPT > ECAP > CG
 Grain size: HPT < ECAP < CG
 Strain (dislocation density): HPT > ECAP > CG

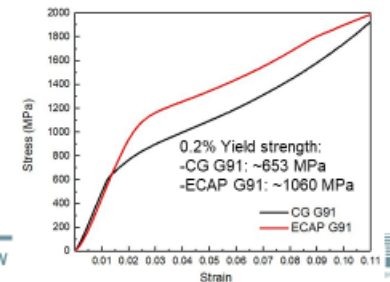
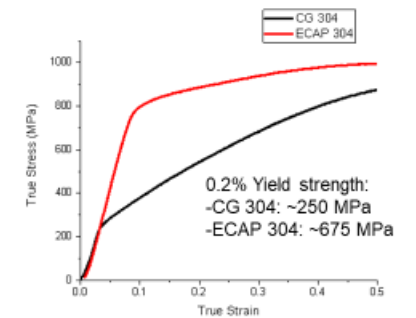
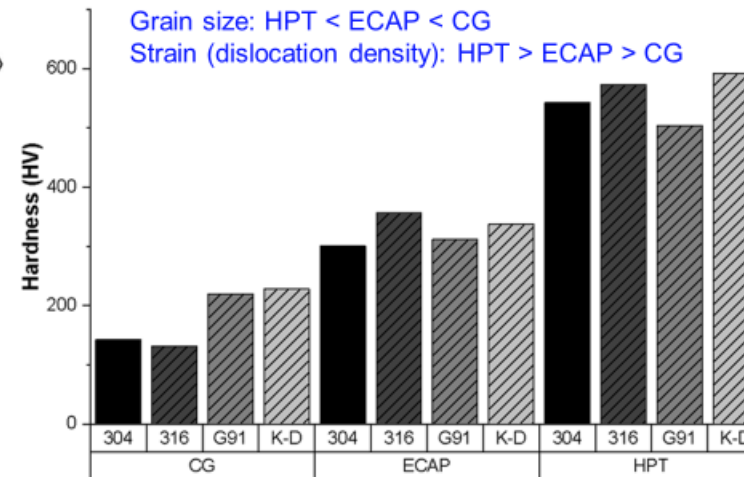

Development of Innovative Manufacturing Approach for ODS Steel Cladding Tubes using a Low Temperature Spray Process

Concept of Manufacturing ODS tube via Cold Spray Process – Three Major Steps

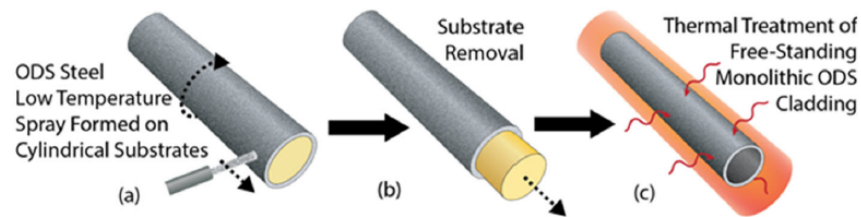

Potential Benefits:

- Eliminates multiple extrusion steps
- Eliminate ball milling step
- Faster and cheaper manufacturing process

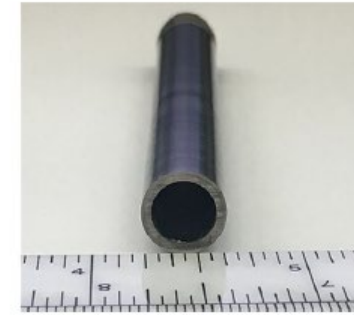

ODS coated Al-alloy mandrel

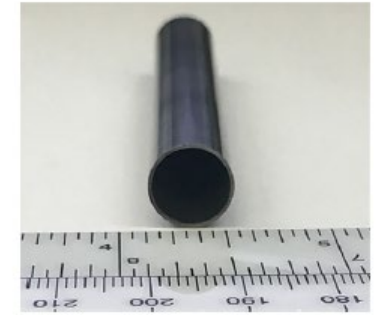

Removal of Al-alloy mandrel

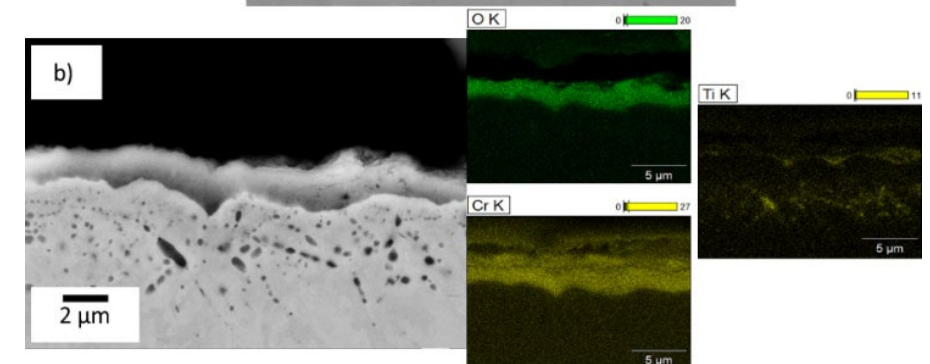
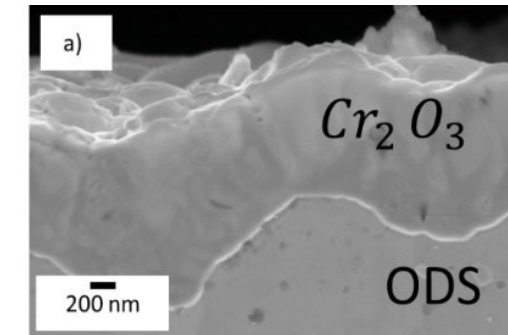

AMM TECHNICAL REVIEW MEETING (FY-20) DEC 2 – 3, 2020



Kumar Sridharan
University of Wisconsin

The Goal is for DOE-NE to be the nexus for AMM development and leadership

- Increase **stakeholder participation** (Industry, DOE offices, Standards, NRC, National laboratories etc.)
- Leverage the **impact of research work** and understand how the technology can potentially be adopted & commercialized
- Continue to reevaluate strategic intent and **identify gaps, needs**
- Increase **collaboration** with DOE programs (identify cross cutting similar needs)
- Establish **direct funded** project(s)
- Re-evaluate Strategy

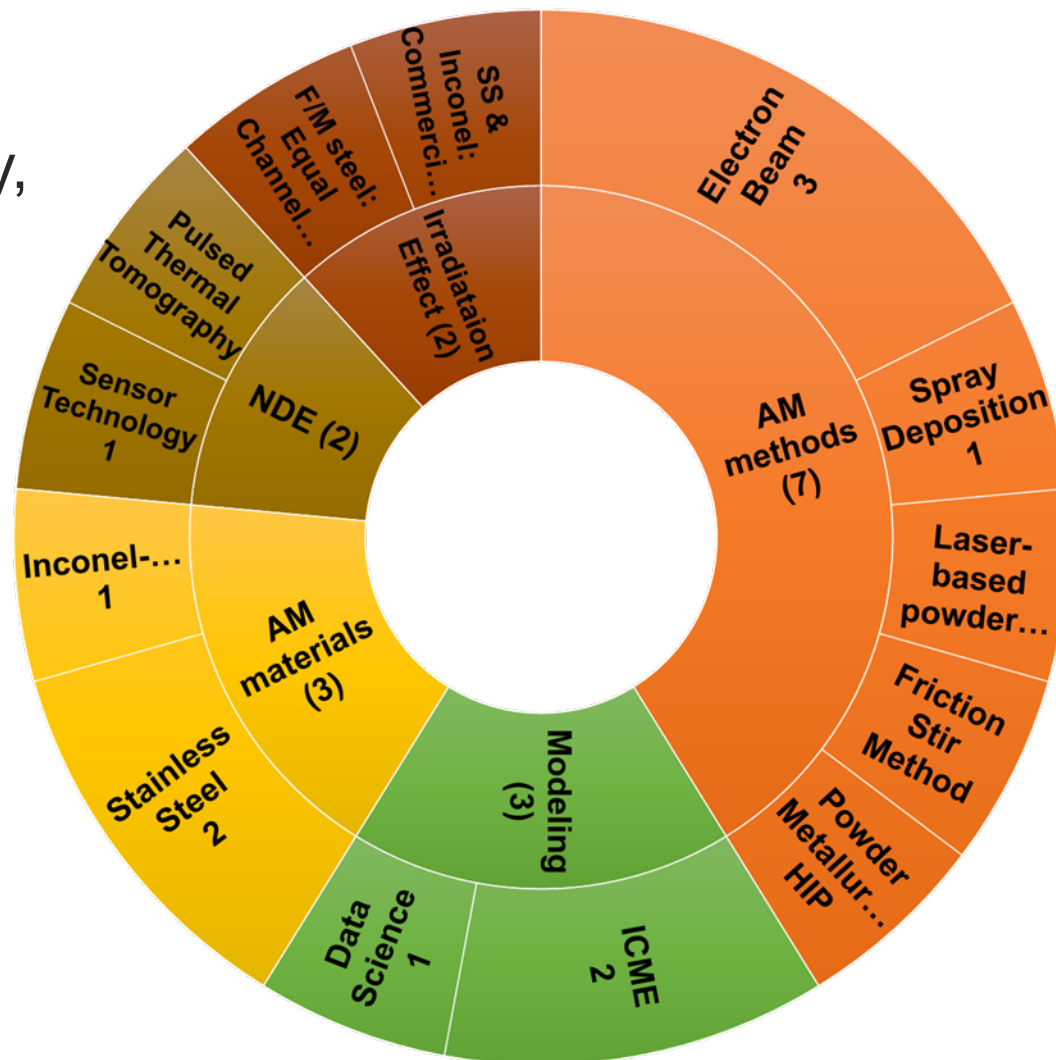

Evaluate AMM Program Award Impact (NEET Awards 2011-2019)

DRAFT

AMM Techniques

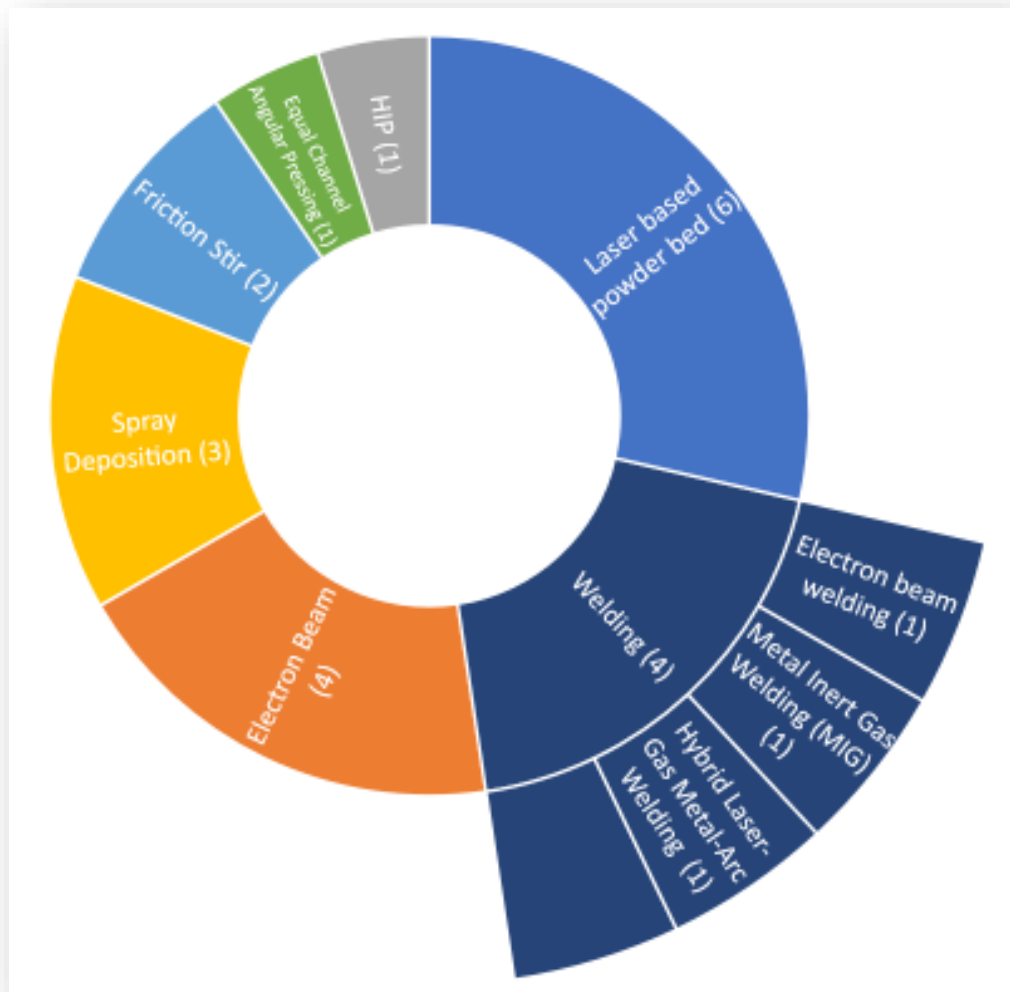

Materials

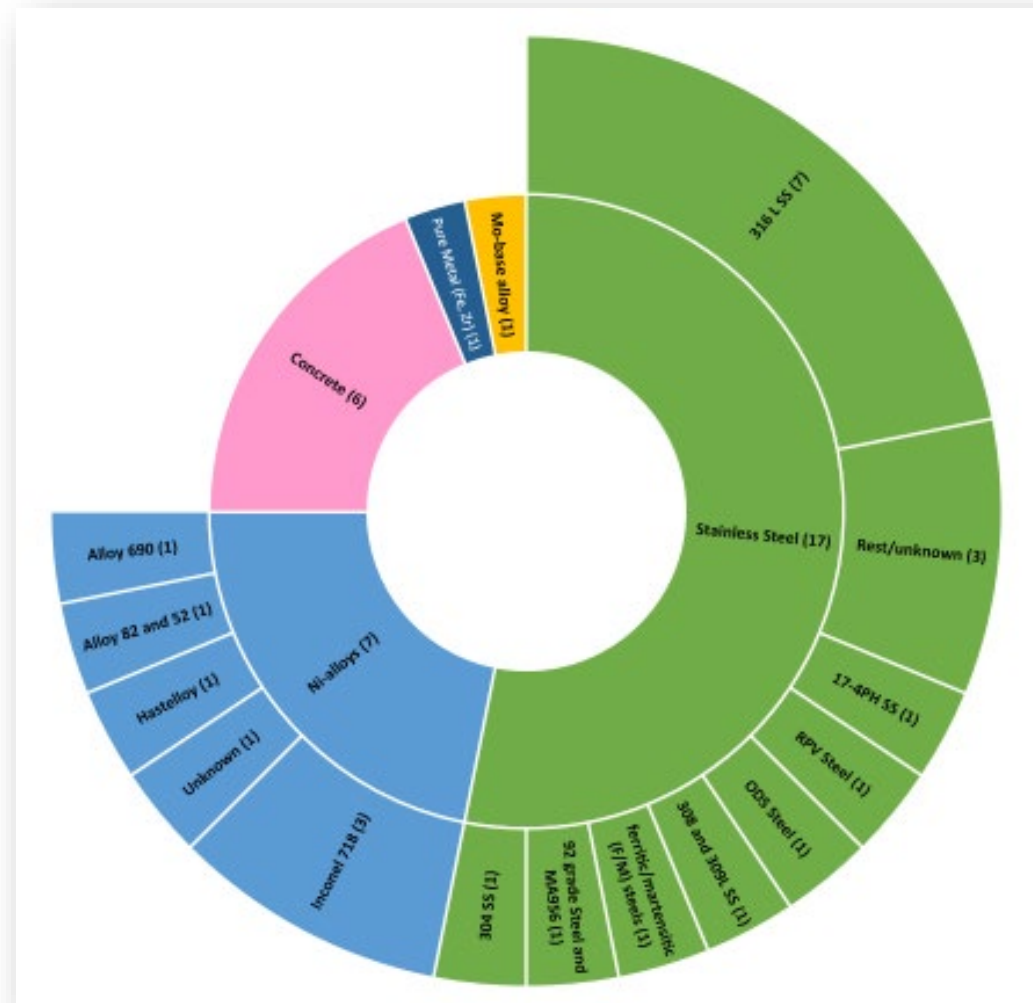



Oregon State
University

COLLEGE OF ENGINEERING

School of Nuclear Science
and Engineering

Perspectives on Materials Degradation Challenges for Fission Battery Deployment

Samuel A. Briggs, Ph.D.

Assistant Professor

School of Nuclear Science & Engineering

Oregon State University

Translating Design Attributes to Materials Performance Requirements



Oregon State University
College of Engineering

- **Economic**
 - Avoid exotic/expensive structural materials where possible
- **Standardized**
 - Repeatable manufacturing, consistency between material heats
- **Installed**
 - Small form factor → High power density
 - Easily transported via conventional means
- **Unattended**
 - Instrumented to provide early warnings regarding materials degradation and failure
- **Reliable**
 - High safety margins - well-understood materials behavior
 - Low operating pressures

These attributes point to fission battery designs based on Gen. IV reactor concepts
– which still have **open questions** regarding **long-term materials performance!**

Gen. IV Reactor Materials



Technical maturity ↑

Coolant (Reactor Concept)	High Working Temperature	High Power Density	High Volumetric Heat Capacity	Low Primary Pressure	Low Reactivity with Air & Water	Coolant & Materials Cost
Water (PWR)	☹️	😐	😊	☹️	😊	😊
Sodium (SFR)	😐	😊	😐	😊	☹️	😐
Helium (GCR)	😊	☹️	☹️	☹️	😊	😐
Salt (FHR/MSR)	😊	😊	😊	😊	😊	☹️
Lead (LCFR)	😊	😊	😐	😊	😐	☹️
Novel Designs	?	?	?	?	?	?

*Adapted from ORNL MSR Workshop 2017

Gen. IV Reactor Materials



Oregon State University
College of Engineering

- Materials requirements obviously shift with operational envelope
- Where do fission batteries fit on this plot?
- **Shorter design lifetimes and lower powers offer advantages for materials selection compared to commercial reactor designs**

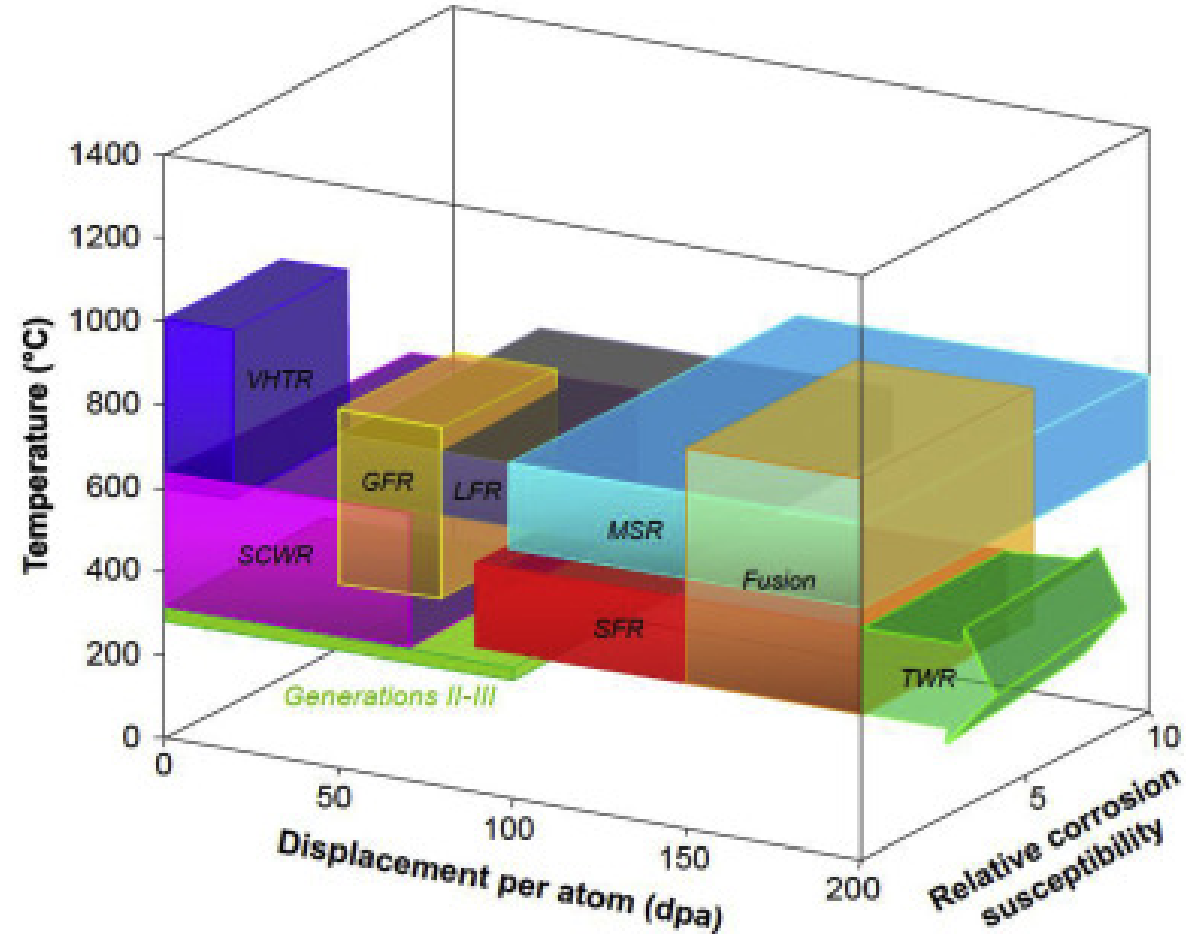

Gen. IV Reactor Materials



Availability of Reactor
Performance Data

Structural Material	High Working Temperature	Cost	Radiation Tolerant	Low DBTT	Corrosion Resistance (Na/Salt)	Code Qualified?
316 SS	☹️	😊	☹️	😊	😊 / 😞	😊
Ni-based Alloys	😊	☹️	☹️	😊	☹️ / 😊	😞
F/M Steels	😞	😊	😊	😊	😊 / 😞	😞
Mo/Refractory Alloys	😊	😞	😊	☹️	☹️ / 😊	😞
SiC	😊	😞	😊	😞	Mixed	😞
HEAs	😊	😞	😊	?	😊	😞

Temperature Effects on Material Properties



- Tensile strength of materials goes down with increasing temperature
- Microstructural engineering can help to offset the effect of this behavior, but adds cost (e.g., oxide dispersion strengthening)

Figure 1
Hot-Strength Characteristics (2)

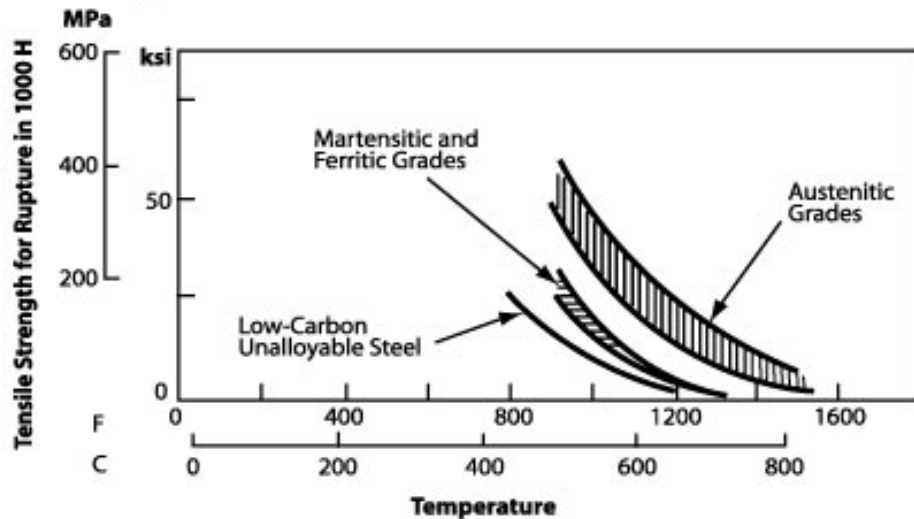

Comparing tensile strengths for different grades of steel

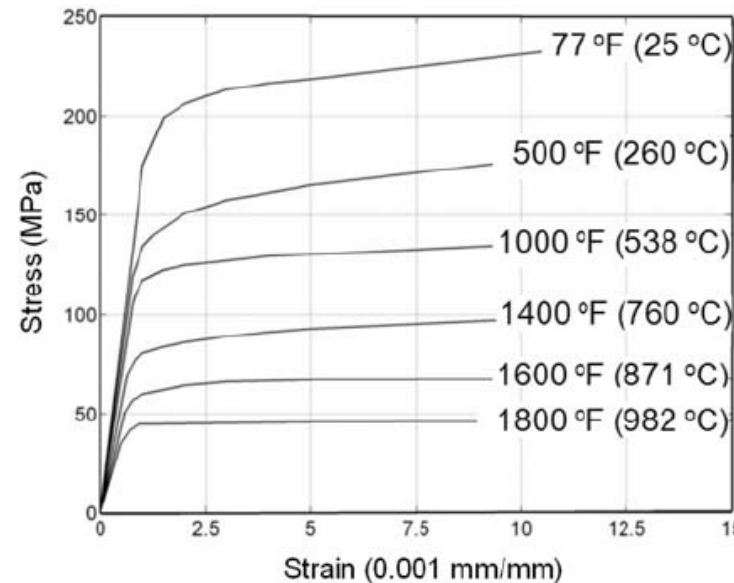

Stress/strain curves for 316 stainless steel at varying temperatures

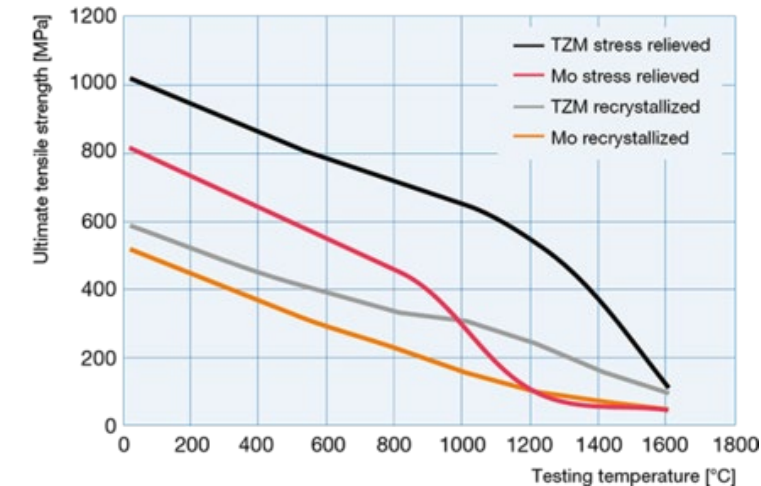

Typical tensile strength for Mo and TZM sheet material in stress relieved and recrystallized conditions

Temperature Effects on Material Properties



Oregon State University
College of Engineering



- Materials also become more susceptible to creep failure at higher temperatures
- Irradiation further enhances creep rate
- Microstructural engineering can also help to reduce creep rate

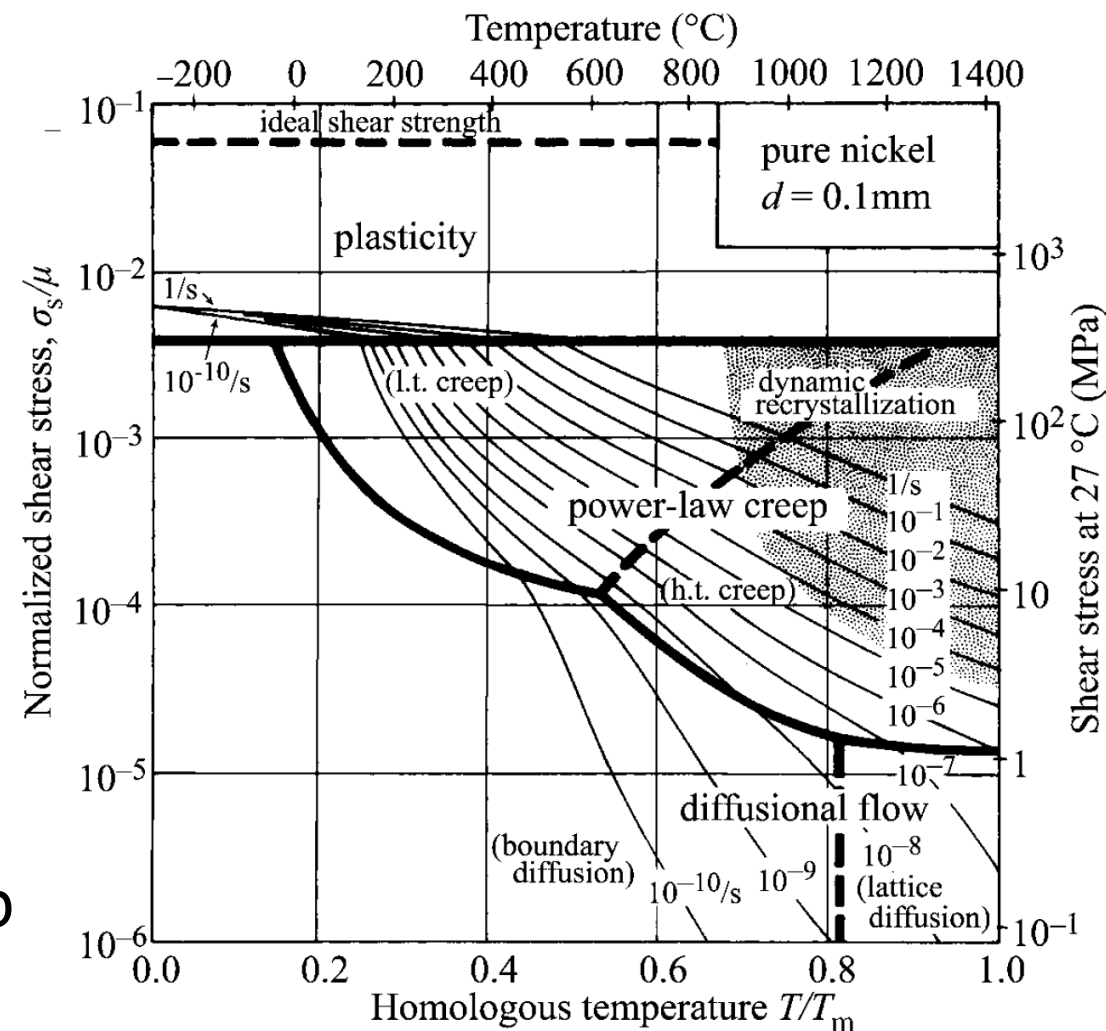

Temperature Effects on Material Properties



- However, stability of nanostructures at high temperatures (especially under irradiation) can limit the effectiveness of microstructural engineering

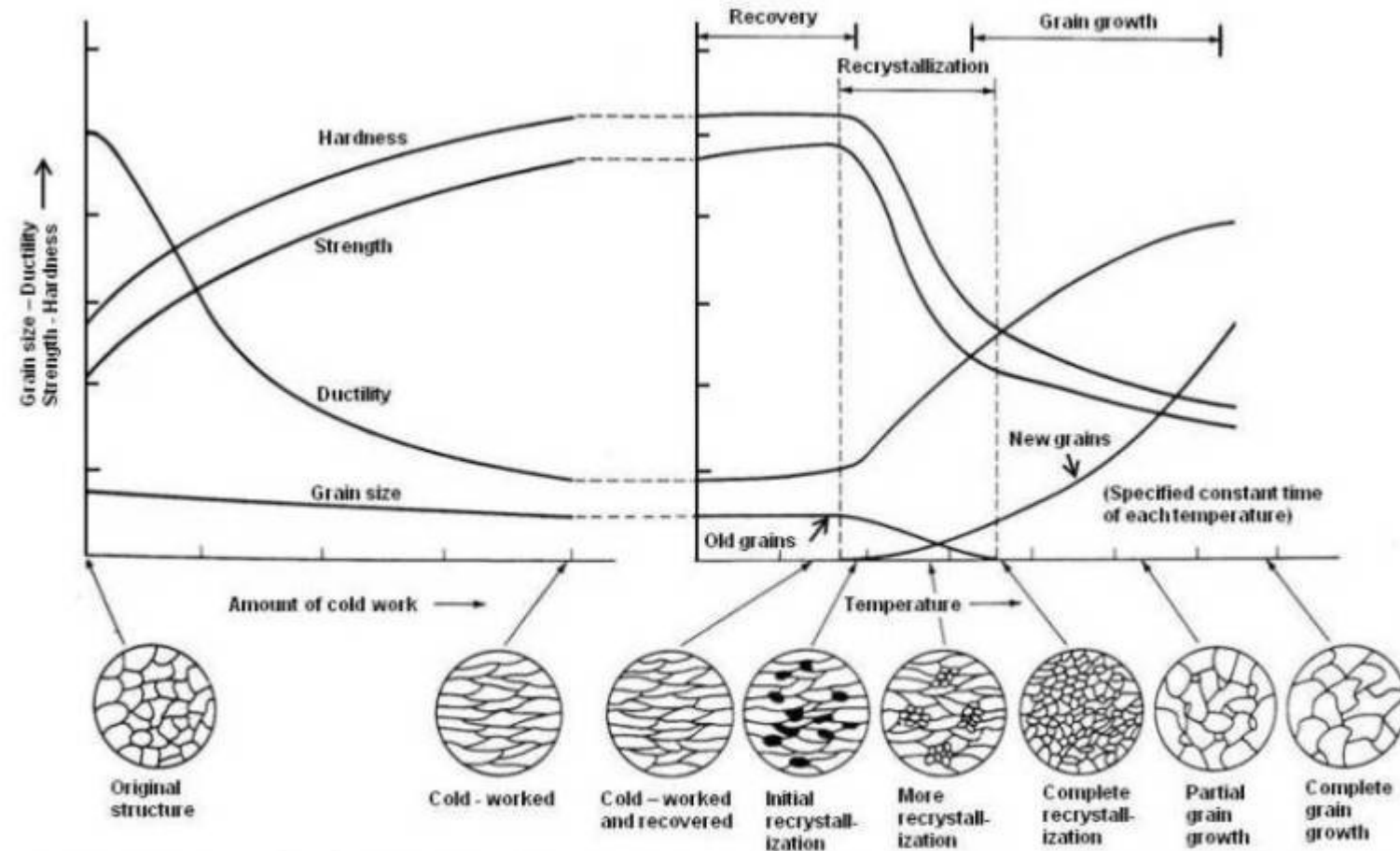

Schematic Representation of the Cold-worked and Anneal Cycle showing the effects on Properties and Microstructure

Radiation Damage at High Temps



Oregon State University
College of Engineering

- Radiation-induced swelling, hardening, segregation are generally less severe at high temperatures
- **General lack of irradiation effects data at high temperatures**

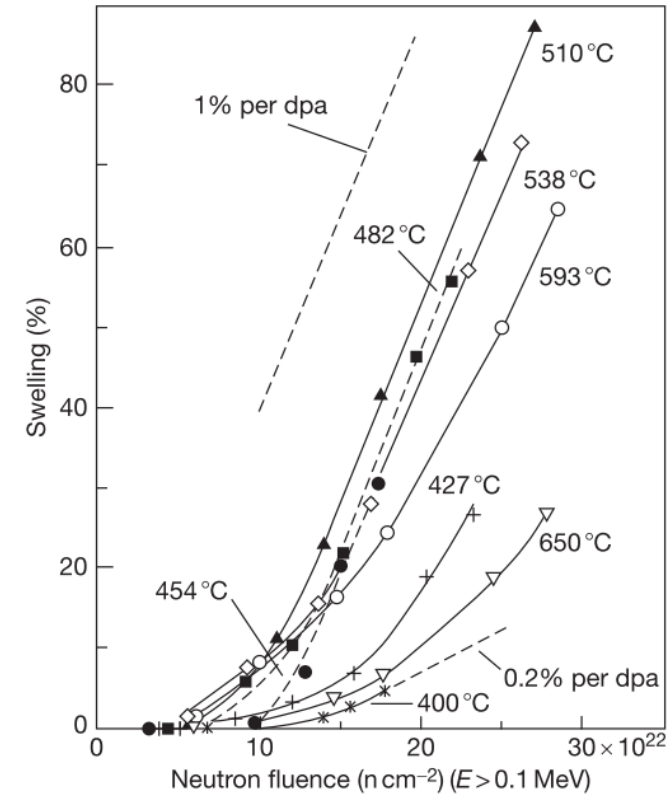
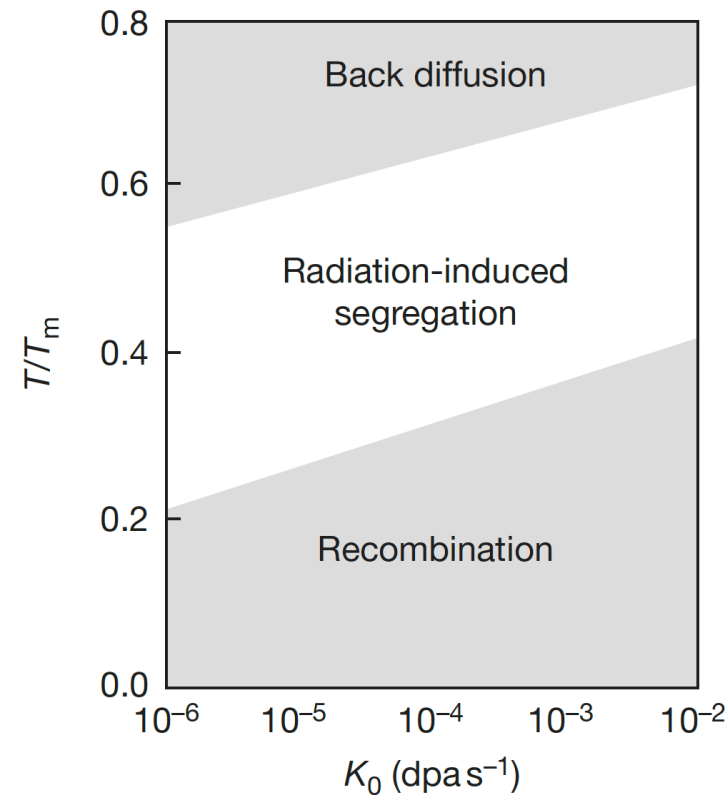
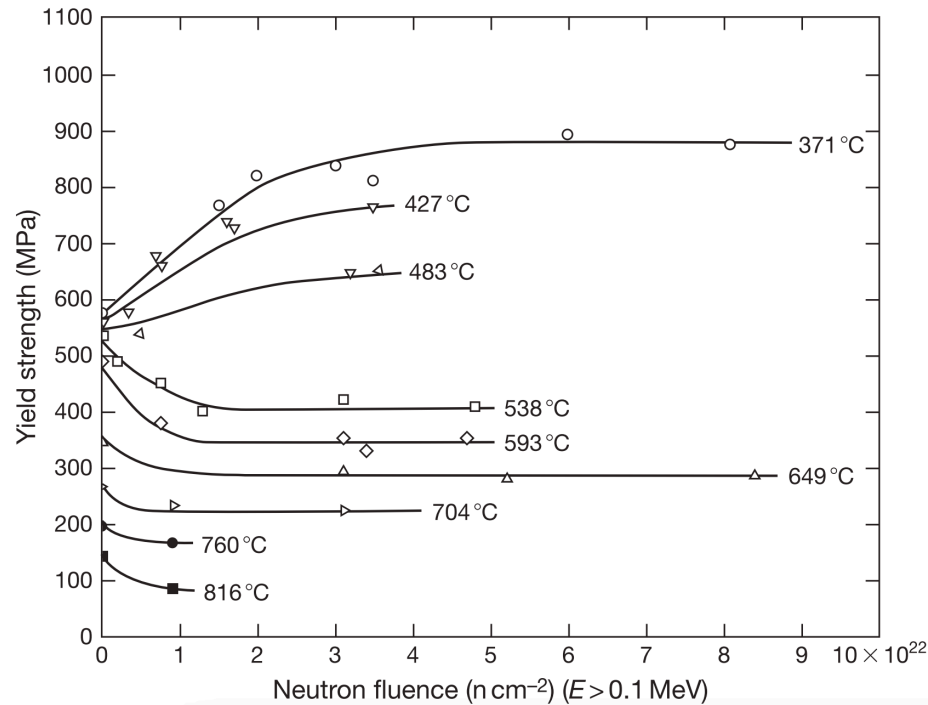

[1] Fish, R. L.; Cannon, N. S.; Wire, G. L. In Effects of Radiation on Structural Materials; Sprague, J. A., Dramer, K., Eds.; ASTM: Philadelphia, PA, 1979; ASTM STP 683, p 450.

[2] M. Nastar, F. Soisson, Radiation-induced segregation. In Comprehensive Nuclear Materials, Elsevier Inc., 2012.

[3] F.A. Garner, Recent insights on the swelling and creep of irradiated austenitic alloys, J. Nucl. Mater. 122–123 (1984) 459–471.

Helium Embrittlement



- He embrittlement is likely to be life-limiting factor in many common structural materials, specifically those containing Ni
- ^{59}Ni and other (n, α) reactions – He migrates to GBs

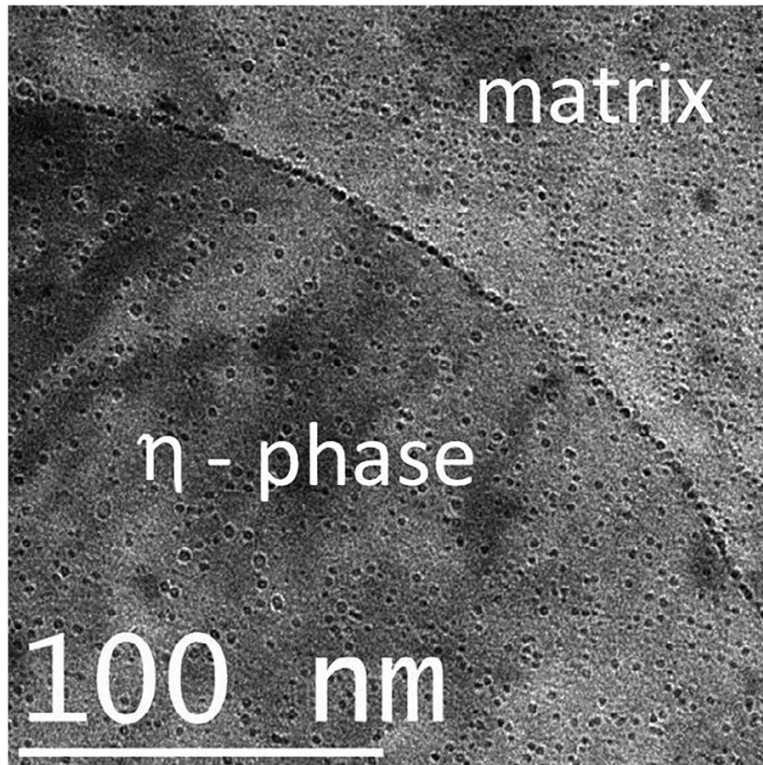

TEM image of an η -phase precipitate in X-750 with bubbles concentrated on the precipitate-matrix interface

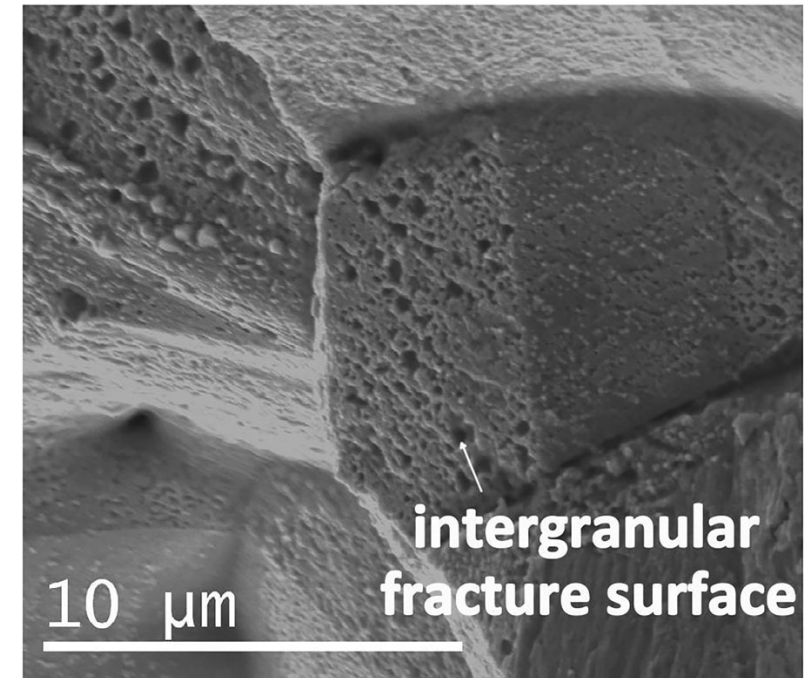

SEM image of a fracture surface of X-750 irradiated to ~ 55 dpa at 300–330°C. The intergranular fracture surface shows features indicative of pull out and remaining grain boundary precipitates. The sample contained 18 000 appm helium

Helium Embrittlement



Oregon State University
College of Engineering

- Stress further enhances this He embrittlement effect



316 SS pre-implanted to 100 appm He and creep tested at 1023 K – preferred bubble growth on GBs perpendicular to applied stress



316 SS tested at 1023 K for 25 hr at a stress of 50 Mpa and a final He concentration of 2500 appm

[1] H. Schroeder, W. Kesternich, H. Ullmaier, Helium effects on the creep and fatigue resistance of austenitic stainless steels at high temperatures, Nucl. Eng. Des. 2 (1985) 65–95.

Coolant Corrosion



- Corrosion and thermally-driven mass transport occurs in both liquid metals, molten salts
- Coolant impurities also tend to drive/increase corrosion rates

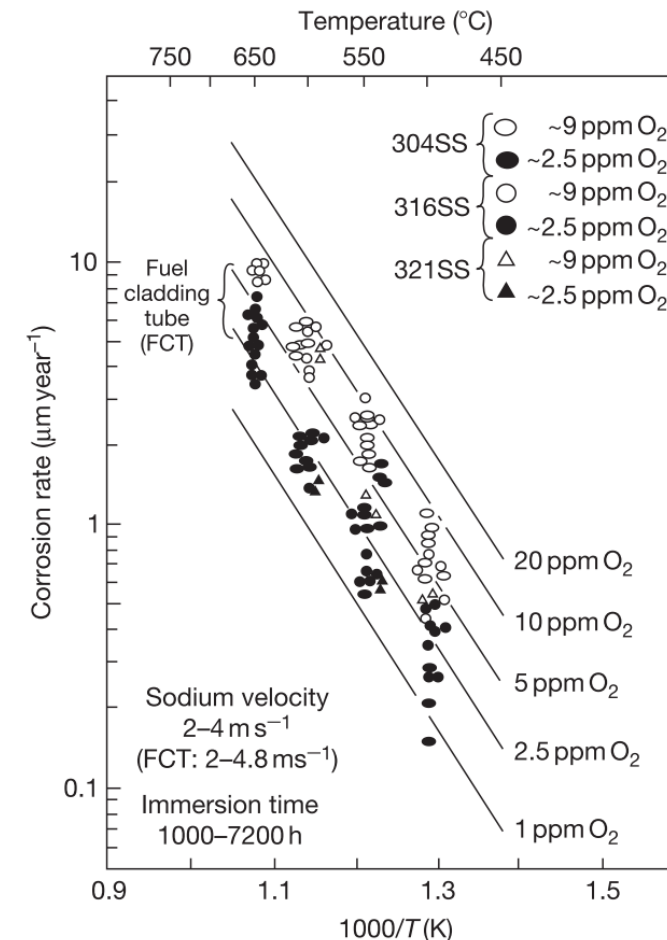
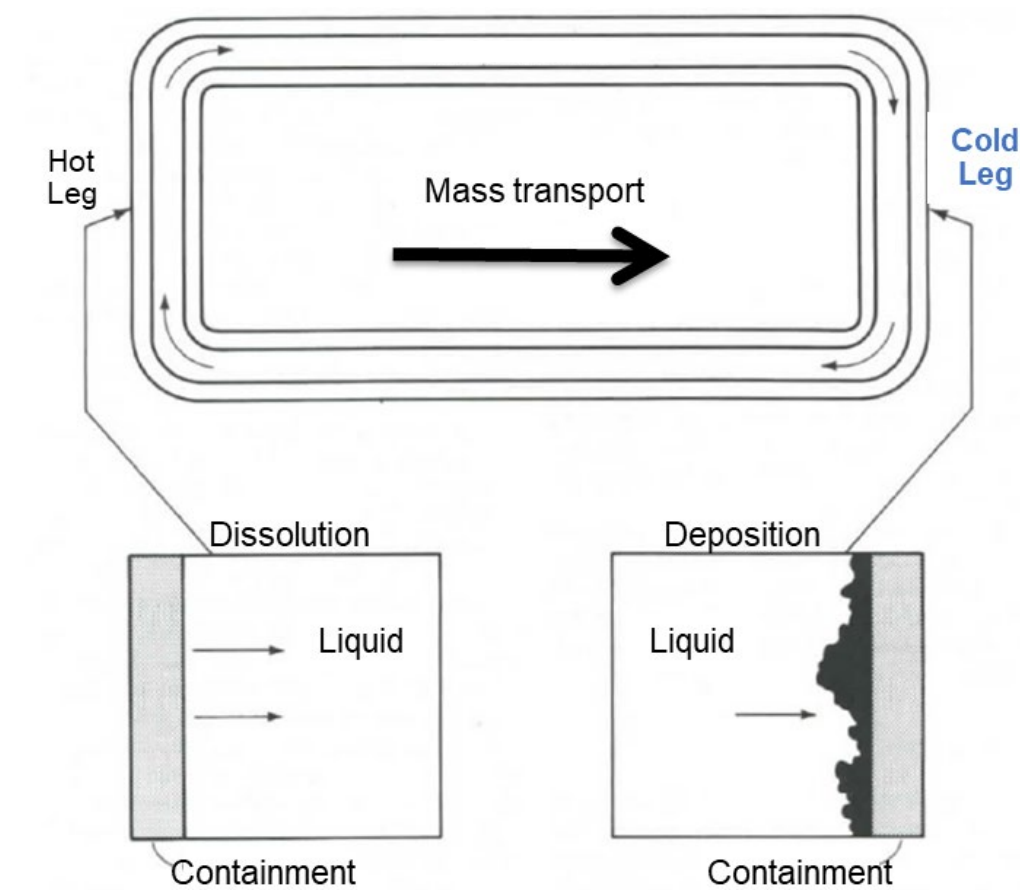

Coolant Corrosion



- Corrosion and thermally-driven mass transport occurs in both liquid metals, molten salts

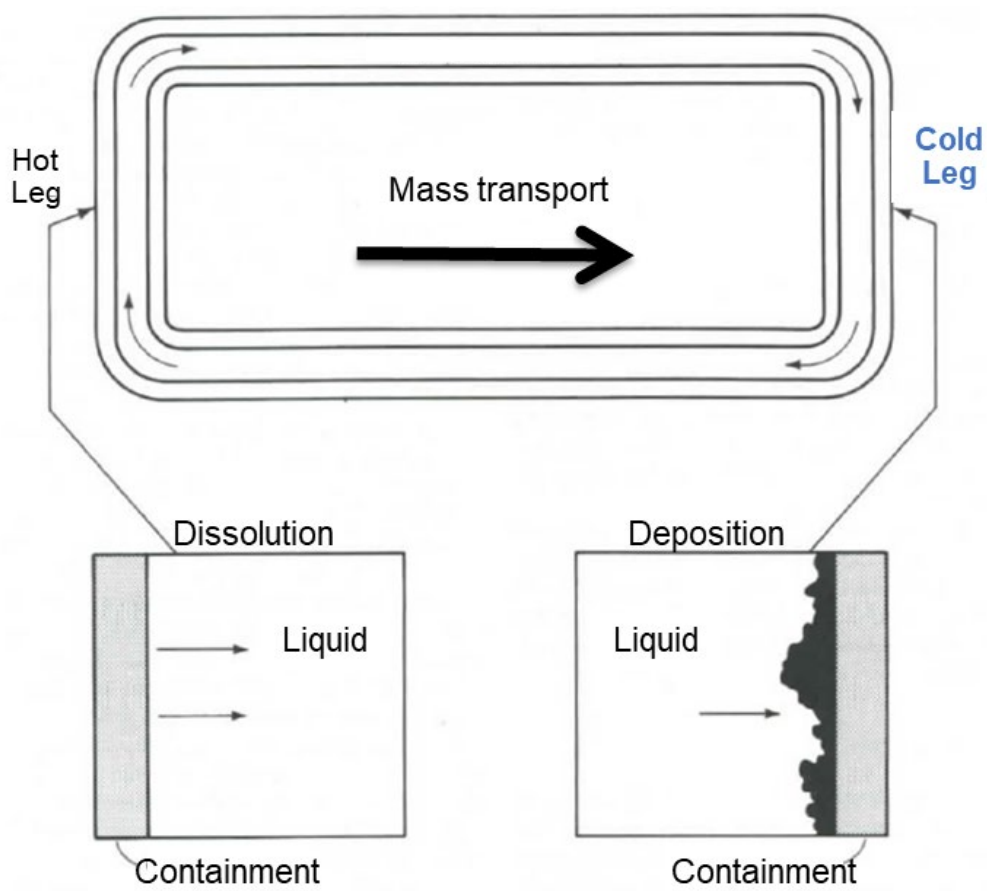

- Coolant impurities also tend to drive/increase corrosion rates

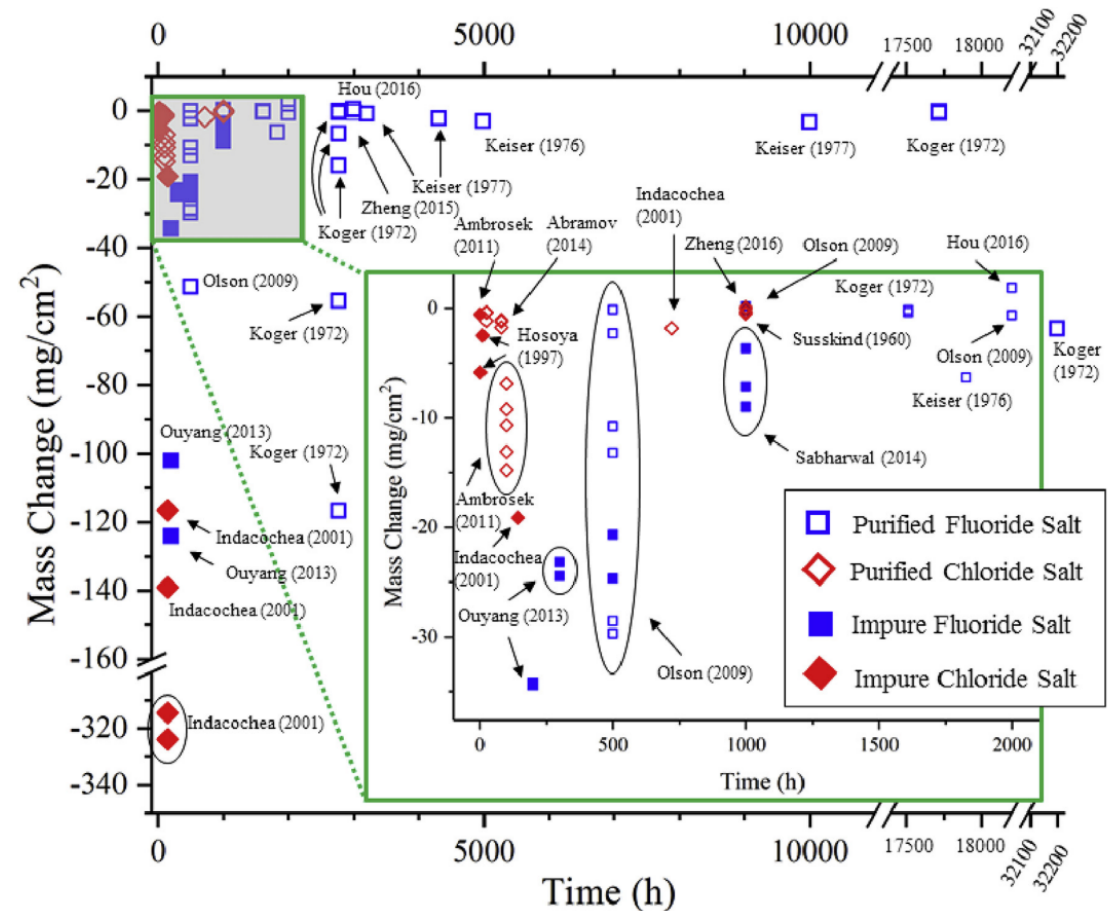

Corrosion Mitigation

- Chemistry Control?
 - Not likely in a passive, closed system
- Anodic/Cathodic Protection?
 - Maybe? Clever uses of sacrificial anodes?
- Coatings/Claddings/Corrosion Barriers?
 - Likely the preferred route to protect conventional materials and avoid driving up costs

Robust, passive strategies for in-reactor corrosion mitigation are currently lacking for Gen IV designs

All samples exposed to KCl-MgCl₂ for 300 hours at 750 C

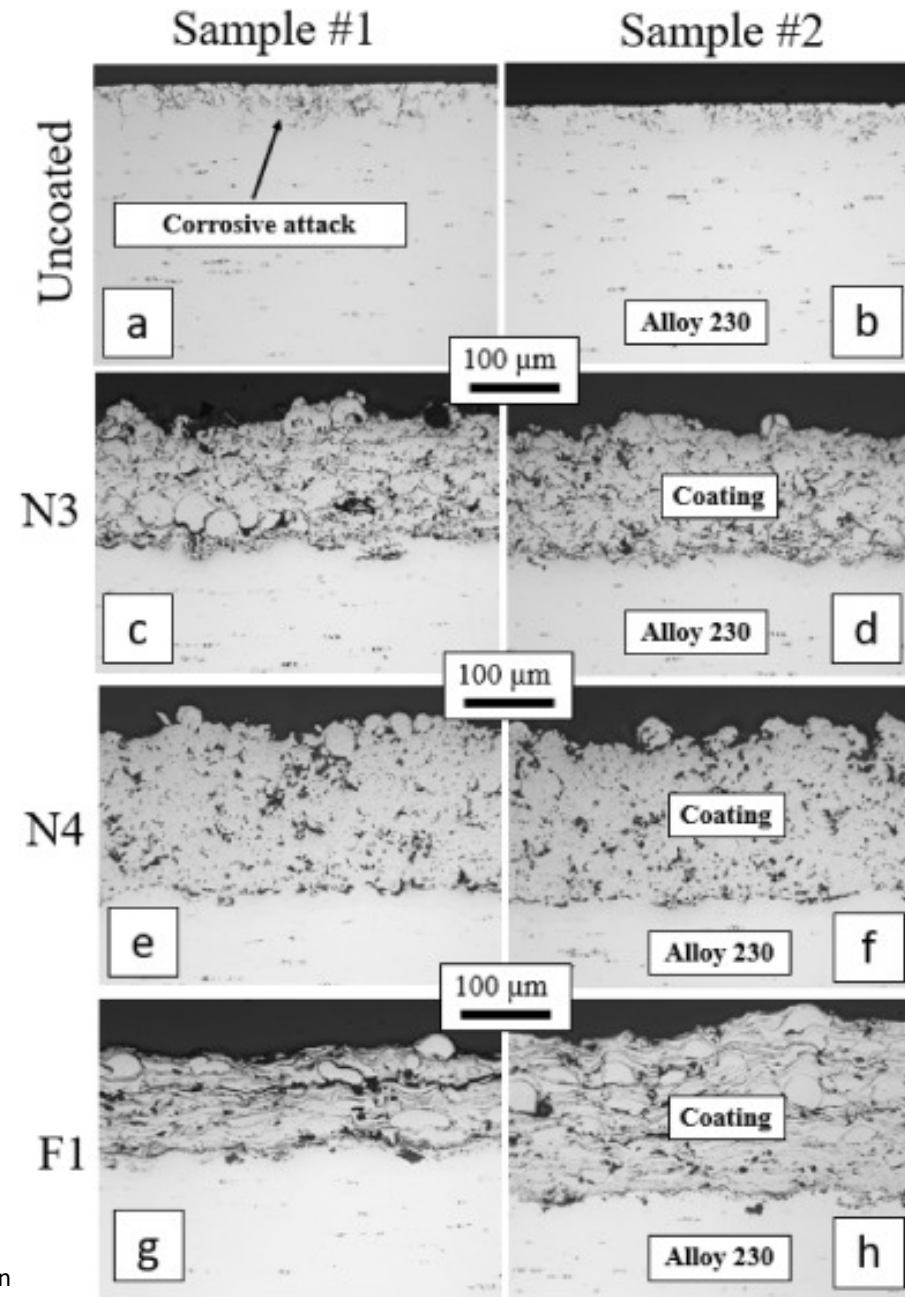

Integral Effects

- Individual environmental stressors often compound to further enhance (and sometimes reduce) materials degradation
 - Irradiation-Assisted Stress Corrosion Cracking
 - Corrosion Fatigue
 - Irradiation Creep
 - He embrittlement with stress
 - Irradiation decelerated molten salt corrosion
- Integral effects tests are required for additional insight into synergies between stressors and expected materials performance

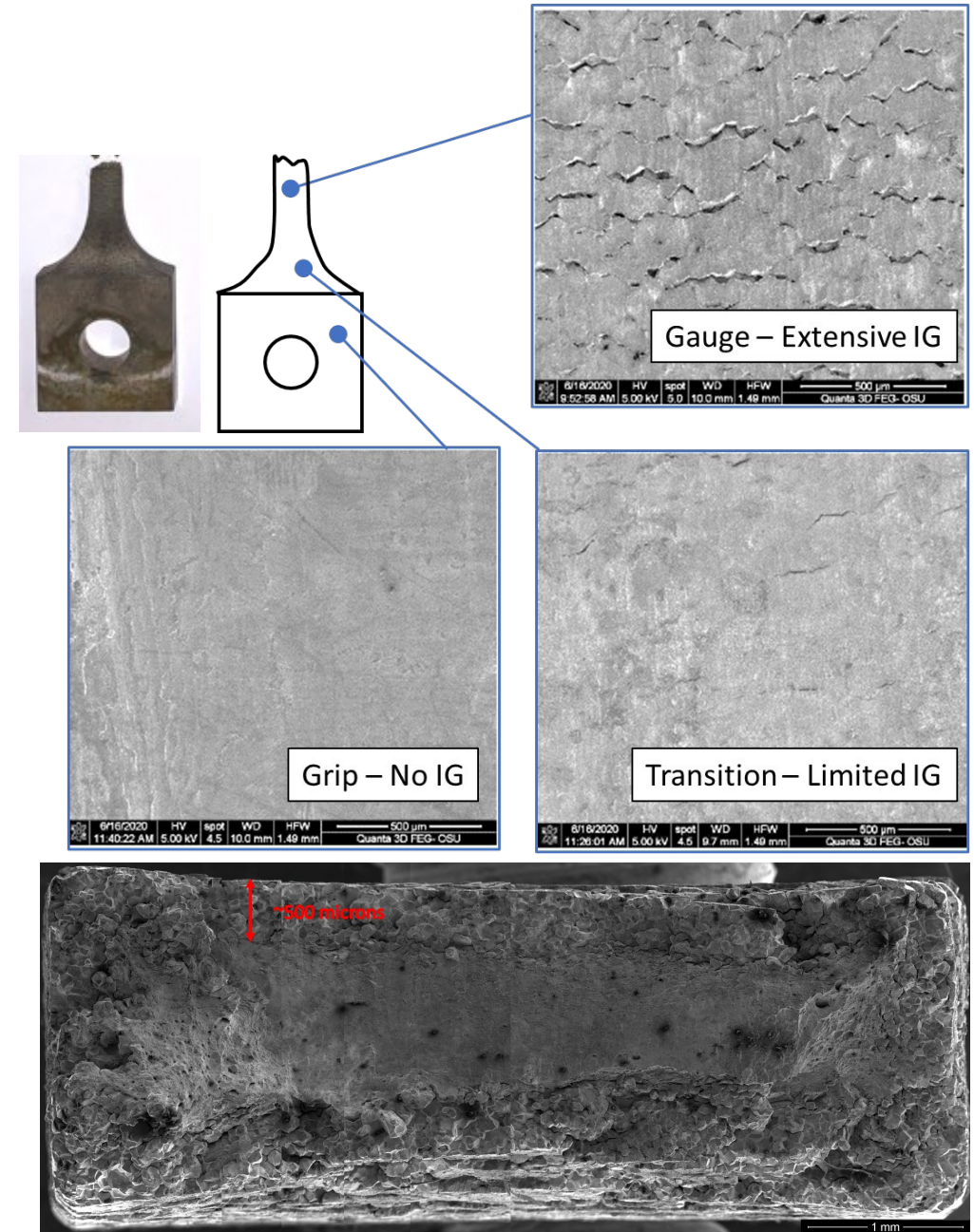

316L following slow-strain rate testing in FLiNaK for 84 hrs at 600 C

Unique Considerations: Transportation

- Relocation of fission batteries after deployment necessitates that materials survive transport following environmental degradation
 - Vibrations, incidental impacts
- May constrain the extent of tolerable embrittlement
- Frozen reactor coolant could potentially provide additional stability during transit



Leveraging Advanced Manufacturing



Oregon State University
College of Engineering

- Advanced manufacturing continues to expand our materials and system design envelopes
 - e.g., building oxide dispersion-strengthened components without the need for expensive powder metallurgy
- Innovations needed in quality control for acceptance/qualification of fabricated components
 - Need more robust methods of guaranteeing performance for a given component
 - e.g., employing machine learning to correlate build process monitoring with microstructural evolution and performance

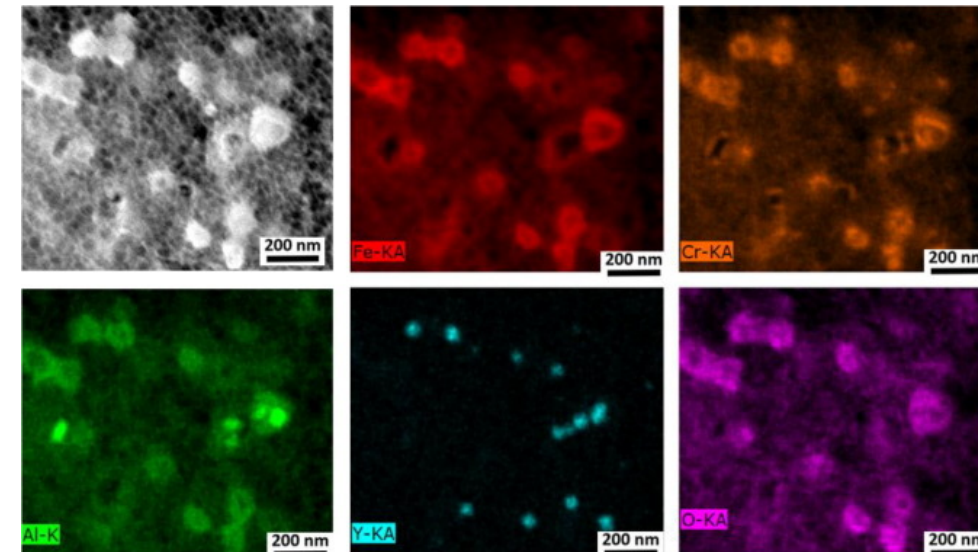
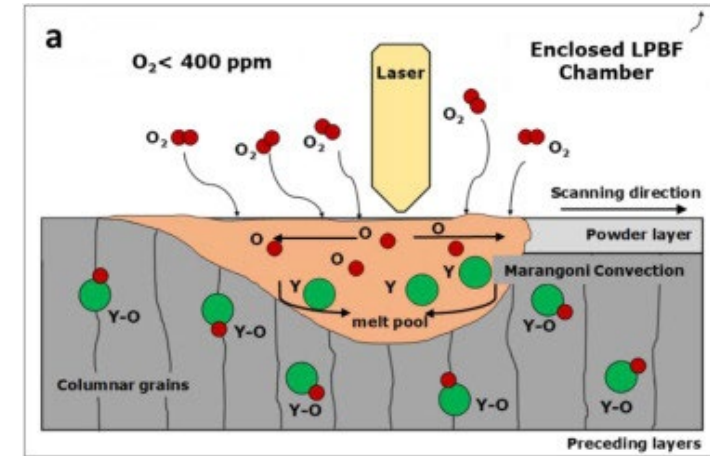

Leveraging Advanced Modeling & Simulation



Oregon State University
College of Engineering

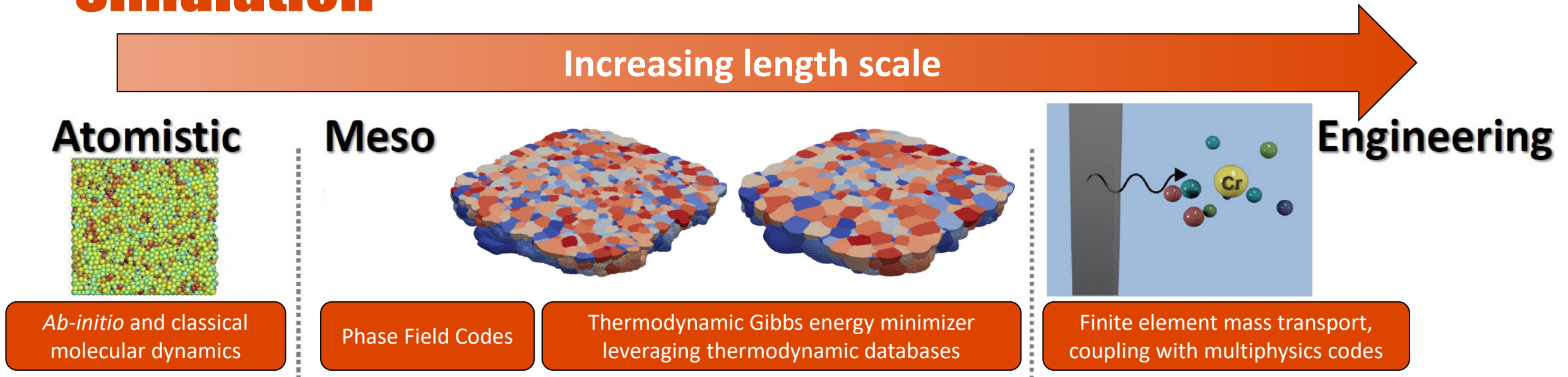

- Capabilities of NEAMS and other M&S tools continue to advance, moving us closer to predictive modeling of materials/system performance
- Need to continue to build up reference databases from first principles and experimental data

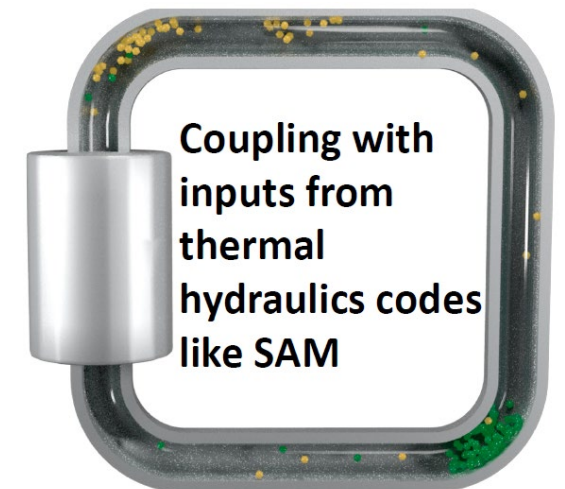

Leveraging Advanced Modeling & Simulation



Oregon State University
College of Engineering

- Modern machine learning and data science techniques can be used to inform materials selection and reduce experimental data requirements
 - Advanced interpolation/extrapolation of properties/performance for sparse datasets
 - Assist with identifying key experiments needed for validation

- Build/expand on current efforts such as Nuclear Materials Discovery & Qualification Initiative

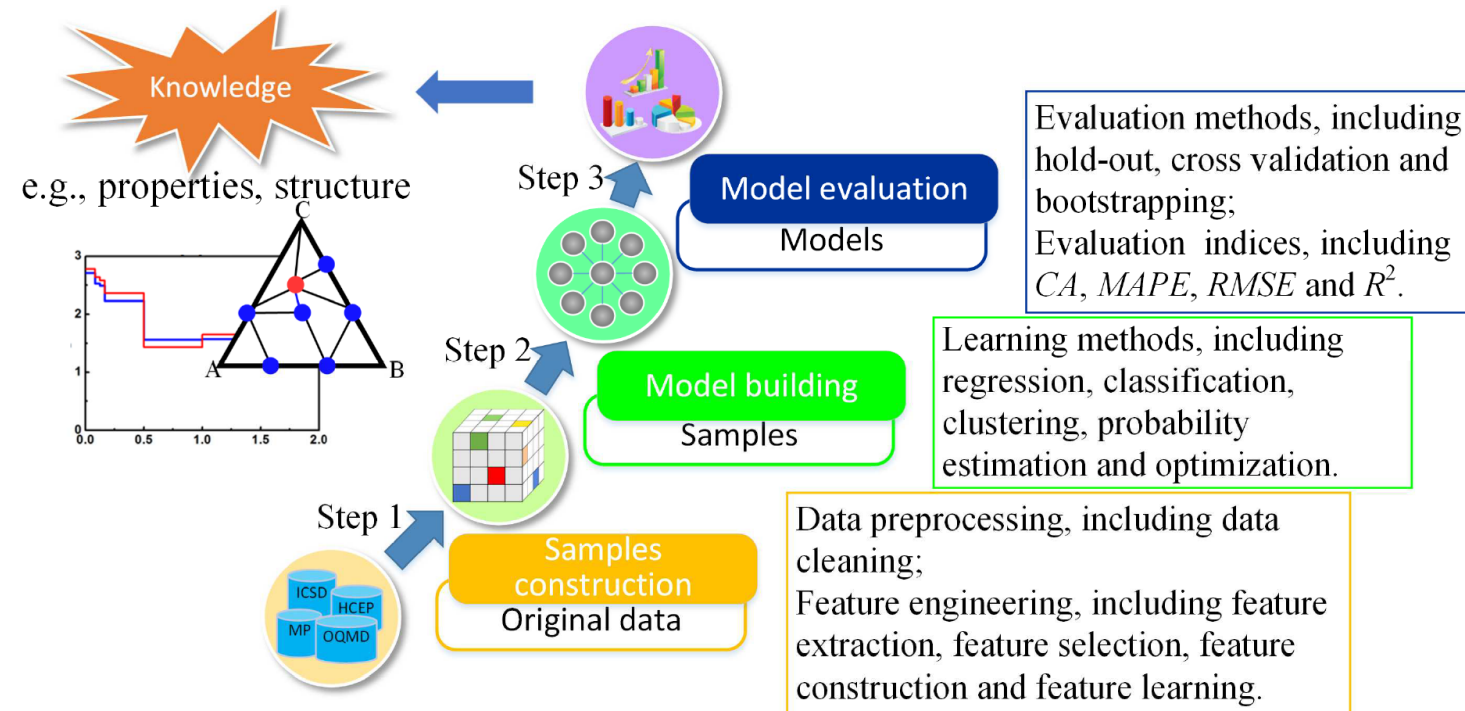

Summary & Conclusions



Oregon State University
College of Engineering

- Many **open questions** regarding materials for in Gen IV reactor designs
- **Relatively limited data** regarding materials degradation/performance in high temperature reactor environments
 - Radiation damage will manifest differently at high temperatures
 - Robust, passive methods for corrosion control in advanced coolants need to be developed
 - Integral effects testing needed to draw connections between separate effects studies
- The lower power and design lifetimes of fission batteries may assuage some of these materials challenges and **provide increased space for innovation**
- Advanced manufacturing and predictive modeling and simulation capabilities can lessen or eliminate perceived materials barriers and **further increase the possible fission battery design envelope**



Oregon State University
College of Engineering

Questions?